

► Upínací trny pro pilové kotouče

Upínací trny s ČELNÍM upínáním

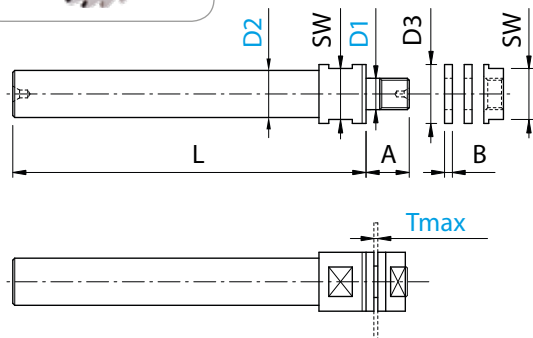

✚ SWISS MADE

Objednáací číslo	D1 h6 (mm)	D2 h6 (mm)	D3 (mm)	L (mm)	A (mm)	B (mm)	SW (mm)	Tmax (mm)	
Pro PRAVÉ otáčky (čelní upínání s pravým závitem)									
2815-3-5	3,0	5,0	5,0	60	7,0	1,0	4,0	3,0	
2815-5-6	5,0	6,0	7,5	70	7,0	1,0	6,0		
2810-5-6		6,0	10,0	70	9,0	2,0	8,0		
2810-5-10	6,0	10,0	10,0	80	9,0	2,0	8,0	6,0	
2810-6-10		10,0	12,0	80	9,5	2,0	10,0		
2810-8-10	8,0	10,0	15,0	80	10,0	2,0	13,0		
2810-8-12		12,0	15,0	90	10,0	2,0	13,0		
2810-10-6	10,0	6,0	18,0	80	10,5	2,0	15,0		
2810-10-10		10,0	18,0	80	10,5	2,0	15,0		
2810-10-16	13,0	16,0	18,0	100	10,5	2,0	15,0		
2810-13-16		16,0	22,0	110	11,0	2,0	19,0		
2811-16-10	16,0	10,0	22,0	80	8,0	2,0	19,0	3,0	
2810-16-20		20,0	26,0	120	12,0	2,0	22,0	6,0	
2810-22-16	22,0	16,0	32,0	132	13,0	2,0	27,0		

Upínací trny se ZADNÍM upínáním

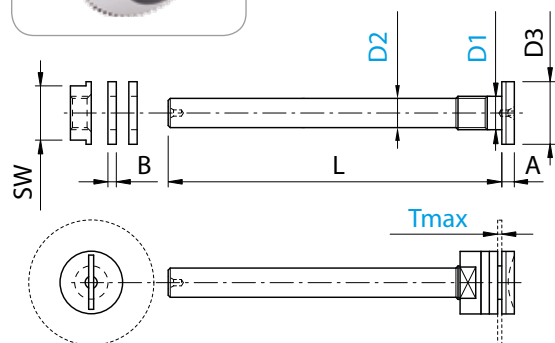

✚ SWISS MADE

Objednáací číslo	D1 h6 (mm)	D2 h6 (mm)	D3 (mm)	L (mm)	A (mm)	B (mm)	SW (mm)	Tmax (mm)	
Pro PRAVÉ otáčky (zadní upínání s levým závitem)									
2820-5-4	5,0	4,0	10,0	50	3,0	2,0	8,0	6,0	
2820-6-5	6,0	5,0	12,0	60	3,0	2,0	10,0		
2820-8-6	8,0	6,0	15,0	70	3,0	2,0	13,0		
2820-8-7	8,0	7,0	15,0	80	3,0	2,0	13,0		
2820-10-6	10,0	6,0	18,0	70	3,5	2,0	15,0		
2820-10-8	10,0	8,0	18,0	90	3,5	2,0	15,0		
2820-13-10	13,0	10,0	22,0	110	3,5	2,0	19,0		
2820-16-12	16,0	12,0	26,0	120	3,5	2,0	22,0		
Pro LEVÉ otáčky (zadní upínání s pravým závitem)									
1820-5-4	5,0	4,0	10,0	50	3,0	2,0	8,0	6,0	
1820-6-5	6,0	5,0	12,0	60	3,0	2,0	10,0		
1820-8-6	8,0	6,0	15,0	70	3,0	2,0	13,0		
1820-10-6	10,0	6,0	18,0	70	3,5	2,0	15,0		