

▶ Upichovací systém CUT-Line

SWISS MADE

VELMITUHÝ upínací systém
= vysoká stabilita
a přesnost při upichování

Držáky H a HX
do Ø42mm

- A **ODDĚLITELNÁ**
horní příložka
- +
- B Upínání
ve **2** bodech
- =
- ZAMEZENÍ OTVÍRÁNÍ**
lůžka destičky při přetažení
- C **DLOUHÁ DESTIČKA**
ukotvená v těle držáku

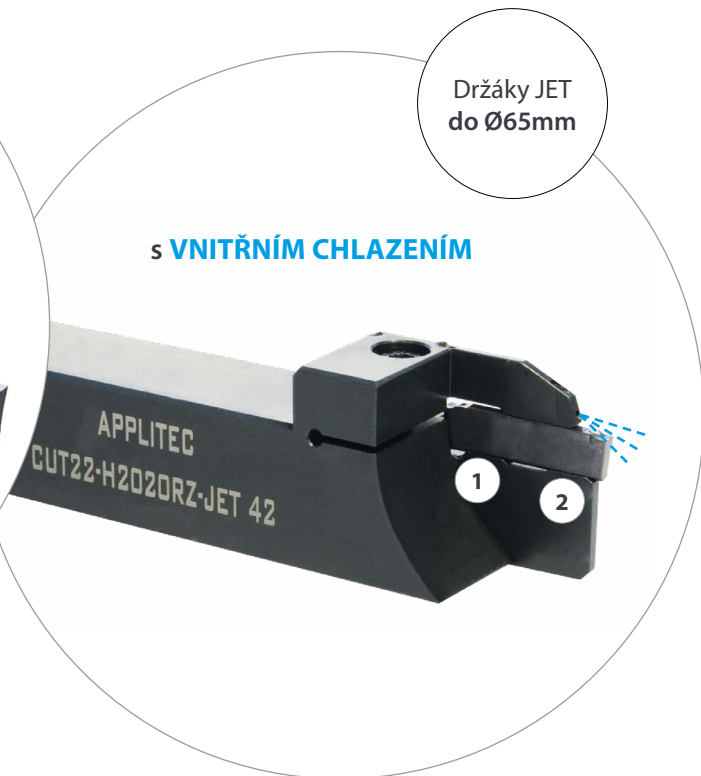
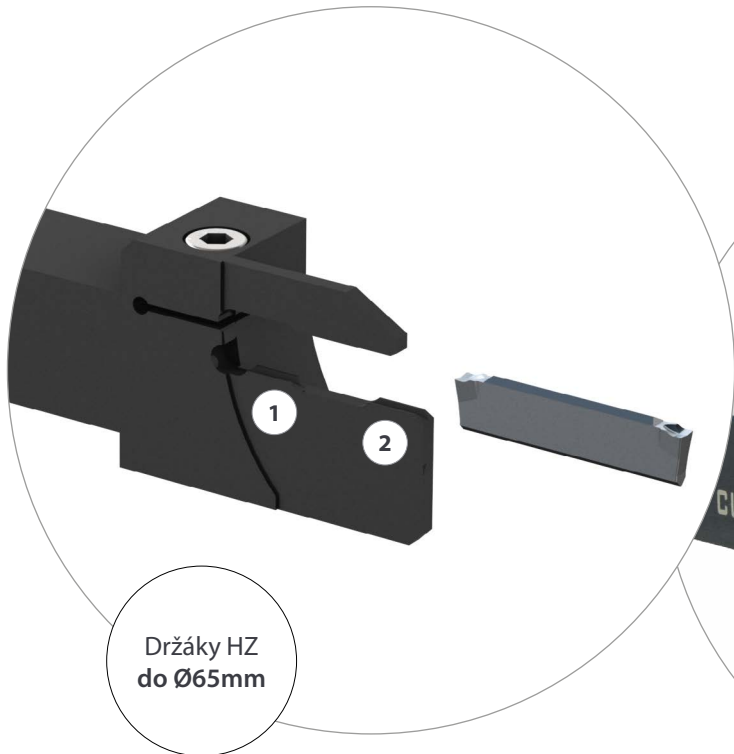
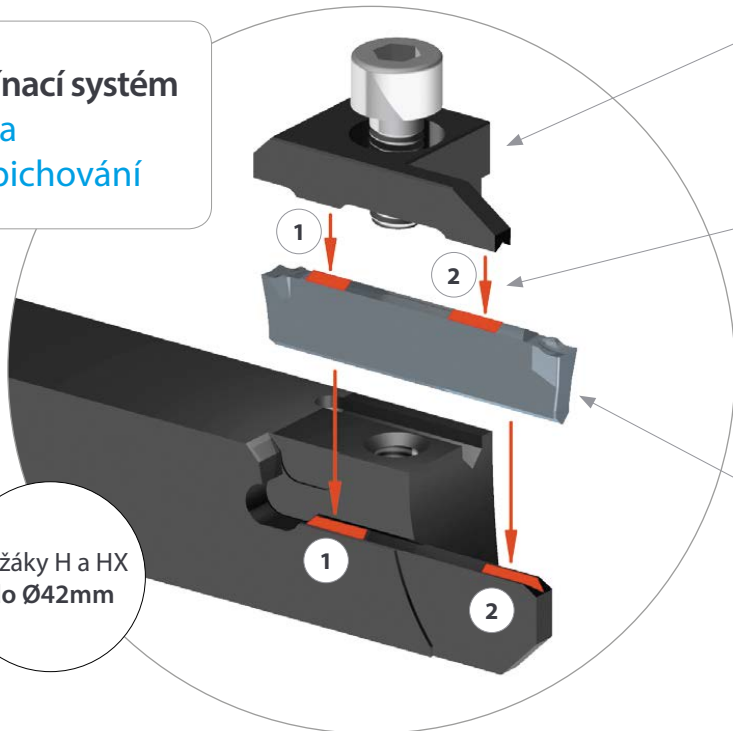

UPÍNÁNÍ
UPICHOVÁNÍ
ZAPICHOVÁNÍ
ISO
PILKY
OTVORY
ZÁVITY
RÁDLOVÁNÍ
ZNAČENÍ
RAŽENÍ

► Upichovací destičky CUT-Line

Výběr velikosti destičky

1,6mm	=	CUT16	=	Ø max. 20mm
2,2mm	=	CUT22	=	Ø max. 42mm
3,1mm	=	CUT31	=	Ø max. 65mm

Příklad objednávky: CUT22-UN-002-TiAIN 20 ks

Výběr sorty destičky

SWISS MADE

TiAIN	Univerzální použití
Tmax	Silnější povlak pro vyšší tepelnou odolnost - první volba pro uhlíkové oceli a vysoce legované oceli
HTA	Vysoká odolnost proti opotřebení, pro stabilní podmínky (nevhodné pro přerušovaný řez)
Zmax	Vysoká houževnatost - první volba pro přerušovaný řez a nestabilní podmínky a NEREZOVÉ OCELI
AS	První volba pro neželezné kovy

UN

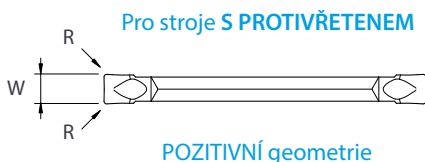

První volba pro NEREZOVÉ oceli

První volba pro UNIVERZÁLNÍ použití

Doporučený posuv: 0,04 - 0,06 mm/ot.

Typ	W ±0,05 (mm)	R (mm)	Objednací číslo	TiAIN	Tmax	Zmax	HTA	AS
CUT16	1,6	0,1	CUT16-UN-001	■	■		■	■
		0,02	CUT16-UN-000	■			■	■
CUT22	2,2	0,2	CUT22-UN-002	■	■	■	■	■
		0,02	CUT22-UN-000	■			■	■
CUT31	3,1	0,2	CUT31-UN-002	■	■	■	■	■
		0,02	CUT31-UN-000	■			■	■

TN

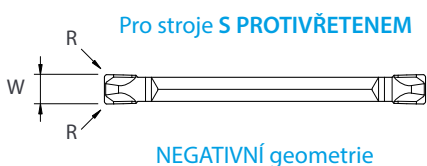

!
NENÍ VHODNÉ pro austenitické NEREZOVÉ OCELI

První volba pro UHLÍKOVÉ a LEGOVANÉ oceli při vyšších posuvech

Doporučený posuv: 0,08 - 0,15 mm/ot.

Typ	W ±0,05 (mm)	R (mm)	Objednací číslo	TiAIN	Tmax	Zmax
CUT22	2,2	0,2	CUT22-TN-002	■	■	■
CUT31	3,1	0,2	CUT31-TN-002	■	■	■

UL UR

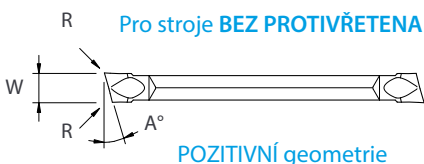

Doporučený posuv: 0,04 - 0,06 mm/ot.

Typ	W ±0,05 (mm)	A	R (mm)	Objednací číslo		TiAIN	HTA	AS
				LEVÉ	PRAVÉ			
CUT16	1,6	8°	0,02	CUT16-UL-800	CUT16-UR-800	■	■	■
		15°	0,02	CUT16-UL-1500	CUT16-UR-1500	■	■	■
CUT22	2,2	8°	0,2	CUT22-UL-802	CUT22-UR-802	■	■	■
		8°	0,02	CUT22-UL-800	CUT22-UR-800	■	■	■
CUT31	3,1	15°	0,02	CUT22-UL-1500	CUT22-UR-1500	■	■	■
		8°	0,2	CUT31-UL-802	CUT31-UR-802	■	■	■
		8°	0,02	CUT31-UL-800	CUT31-UR-800	■	■	■
		15°	0,02	CUT31-UL-1500	CUT31-UR-1500	■	■	■

► Upichovací držáky CUT-Line

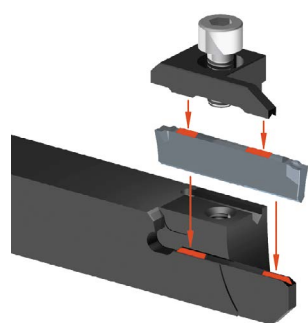

Držáky H a HX
Vyměnitelná horní příložka

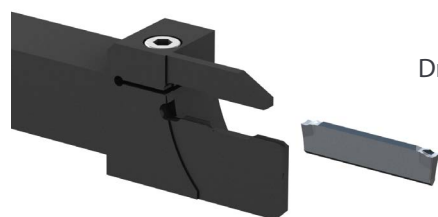

Držáky HZ

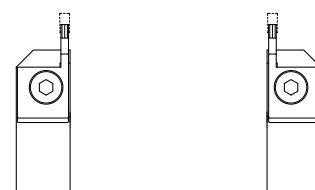
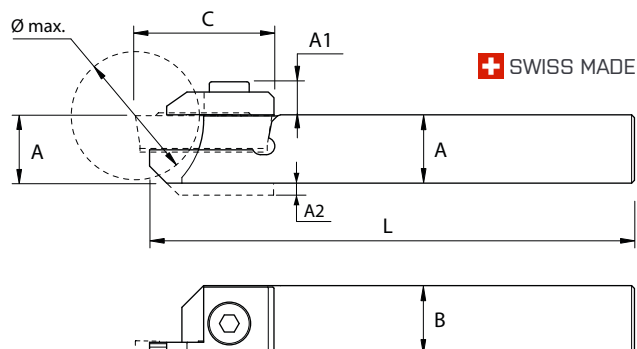

Destička	Ø max. (mm)	Typ držáku	A x B x L (mm)	A1 (mm)	C (mm)	A2 (mm)	Objednací čísla	
							LEVÉ	PRAVÉ
1,6 CUT16	Ø 16	H	8 x 10 x 115	6,2	19,5	2	CUT16-H0810L	CUT16-H0810R
			10 x 10 x 115	6,2	19,5	-	CUT16-H1010L	CUT16-H1010R
			12 x 12 x 130	6,2	19,5	-	CUT16-H1212L	CUT16-H1212R
			12 x 12 x 90	6,2	19,5	-	CUT16-H1212L-90	CUT16-H1212R-90
			16 x 16 x 130	6,2	19,5	-	CUT16-H1616L	CUT16-H1616R
	Ø 20	HX	20 x 20 x 120	6,2	19,5	-	CUT16-H2020L	CUT16-H2020R
			10 x 12 x 115	6,2	21	2	CUT16-H1012LX	CUT16-H1012RX
			12 x 12 x 130	6,2	21	-	CUT16-H1212LX	CUT16-H1212RX
			12 x 12 x 90	6,2	21	-	CUT16-H1212LX-90	CUT16-H1212RX-90
			16 x 16 x 130	6,2	21	-	CUT16-H1616LX	CUT16-H1616RX
2,2 CUT22	Ø 20	H	20 x 20 x 120	6,2	21	-	CUT16-H2020LX	CUT16-H2020RX
			10 x 12 x 115	6,2	21	-	CUT16-H1012LX	CUT16-H1012RX
			12 x 12 x 130	6,2	21	-	CUT16-H1212LX	CUT16-H1212RX
			12 x 12 x 90	6,2	21	-	CUT16-H1212LX-90	CUT16-H1212RX-90
			16 x 16 x 130	6,2	21	-	CUT16-H1616LX	CUT16-H1616RX
	Ø 26	HX	20 x 20 x 120	6,2	21	-	CUT16-H2020LX	CUT16-H2020RX
			10 x 12 x 115	6,4	24	-	CUT22-H1012L	CUT22-H1012R
			12 x 12 x 130	6,4	24	-	CUT22-H1212L	CUT22-H1212R
			12 x 12 x 90	6,4	24	-	CUT22-H1212L-90	CUT22-H1212R-90
			16 x 16 x 130	6,4	24	-	CUT22-H1616L	CUT22-H1616R
	Ø 32	HZ	20 x 20 x 120	6,4	24	-	CUT22-H2020L	CUT22-H2020R
			16 x 16 x 130	6,4	25	4	CUT22-H1012LX	CUT22-H1012RX
			12 x 12 x 130	6,4	25	2	CUT22-H1212LX	CUT22-H1212RX
			12 x 12 x 90	6,4	25	2	CUT22-H1212LX-90	CUT22-H1212RX-90
Ø 42	HZ	16 x 16 x 130	6,4	25	-	CUT22-H1616LX	CUT22-H1616RX	
		20 x 20 x 120	6,4	25	-	CUT22-H2020LX	CUT22-H2020RX	
3,1 CUT31	Ø 34	H	16 x 16 x 130	7	30	-	CUT22-H1616LZ-D32	CUT22-H1616RZ-D32
			20 x 20 x 130	7	30	-	CUT22-H2020LZ-D32	CUT22-H2020RZ-D32
			20 x 20 x 130	7	35	4	CUT22-H1616LZ-D42	CUT22-H1616RZ-D42
	Ø 42	HX	16 x 16 x 130	7	35	-	CUT22-H2020LZ-D42	CUT22-H2020RZ-D42
			20 x 20 x 120	7,8	35	-	CUT31-H1616L	CUT31-H1616R
	Ø 52	HZ	20 x 20 x 120	7,8	35	-	CUT31-H2020L	CUT31-H2020R
			25 x 25 x 140	7,8	35	-	CUT31-H2525L	CUT31-H2525R
			16 x 16 x 120	7,8	37	4	CUT31-H1616LX	CUT31-H1616RX
			20 x 20 x 120	7,8	37	-	CUT31-H2020LX	CUT31-H2020RX
			25 x 25 x 140	7,8	37	-	CUT31-H2525LX	CUT31-H2525RX
Ø 65	HZ	20 x 20 x 140	8	44	5	CUT31-H2020LZ-D52	CUT31-H2020RZ-D52	
		25 x 25 x 140	8	44	-	CUT31-H2525LZ-D52	CUT31-H2525RZ-D52	
		20 x 20 x 140	8	50	5	CUT31-H2020LZ-D65	CUT31-H2020RZ-D65	
			25 x 25 x 140	8	50	-	CUT31-H2525LZ-D65	CUT31-H2525RZ-D65

► Upichovací držáky CUT-Line s chlazením

SWISS MADE

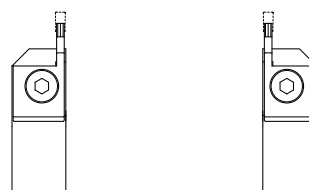
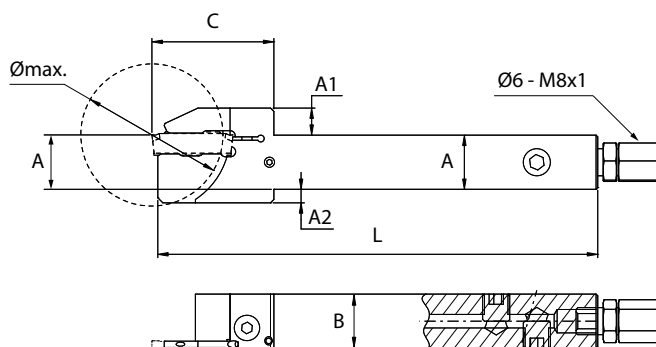

Destička	Ø max. (mm)	Typ držáku	A x B x L (mm)	A1 (mm)	C (mm)	A2 (mm)	Objednací čísla	
							LEVÉ	PRAVÉ
2,2 CUT22	Ø 42	HZ	16 x 16 x 130	8	36	4	CUT22-H1616LZ-JET42	CUT22-H1616RZ-JET42
			20 x 20 x 130	8	36	-	CUT22-H2020LZ-JET42	CUT22-H2020RZ-JET42
3,1 CUT31	Ø 65	HZ	20 x 20 x 140	9	51	5	CUT31-H2020LZ-JET65	CUT31-H2020RZ-JET65
			25 x 25 x 140	9	51	-	CUT31-H2525LZ-JET65	CUT31-H2525RZ-JET65

1 ŠROUB = 2 MOŽNOSTI UPNUTÍ

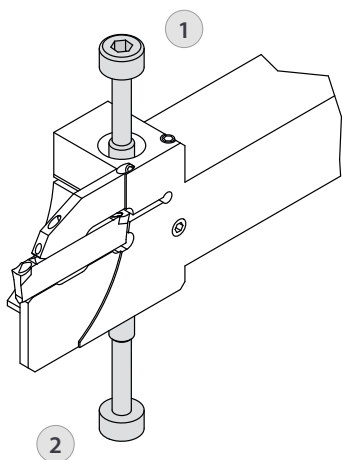

UPÍNÁNÍ

UPICHOVÁNÍ

ZAPICHOVÁNÍ

ISO

PILKY

OTVORY

ZÁVITY

RÁDLOVÁNÍ

ZNAČENÍ

RAŽENÍ