



PM-TECH



FRÉZY PRO OBRÁBĚNÍ OCELÍ

do 52 HRC

INTERAKTIVNÍ PRVKY



► Vhodný prohlížeč

Pro správnou funkci interaktivních prvků doporučujeme k prohlížení katalogu používat program ADOBE READER

Pro snazší orientaci a vyhledávání má katalog následující interaktivní prvky:

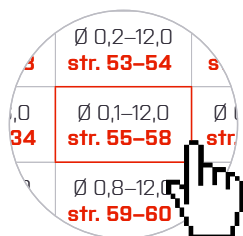

► Čísla stránek v obsahu

Pro rychlou navigaci na vybranou kategorii produktů klikněte v obsahu na příslušnou buňku tabulky s číslem stránky



► Zpět na obsah z katalogu

















Ze kteréhokoliv místa katalogu se snadno dostanete na obsah kliknutím na červené tlačítko „zpět na obsah“ u horního okraje stránky



► Odkazy v zápatí stránky

Pokud máte jakékoli dotazy nebo vás zajímají další naše produkty, stačí kliknout na naši e-mailovou adresu, webovou adresu nebo na logo dole na stránce



Typ	Obrázek	Poznámka	Počet břitů	Série fréz pro obrábění ocelí	
				≤ 52 HRC	G
				0,5 μm - VHM	AICrN
Pro žebrování		Kulové	2	Ø 0,1 - 12,0 str. 4 - 6	
		Ostré	2	Ø 0,1 - 12,0 str. 7 - 8	
		Ostré	4	Ø 0,8 - 12,0 str. 9 - 10	
		Toroidní	2	Ø 0,2 - 16,0 str. 11 - 14	
		Toroidní	4	Ø 1,0 - 12,0 str. 15 - 18	
Kulové		Krátké	2	Ø 0,2 - 12,0 str. 19	
		Standardní	2	Ø 0,1 - 20,0 str. 20	
Ostré		Standardní	2	Ø 0,1 - 20,0 str. 21 - 22	
		Dlouhé	2	Ø 1,0 - 25,0 str. 23	
		Standardní	4	Ø 0,8 - 20,0 str. 24	
		Dlouhé	4	Ø 1,0 - 25,0 str. 25	
		Standardní 45°	4	Ø 1,0 - 20,0 str. 26	
		Hrubovací	3 & 4	Ø 4,0 - 20,0 str. 27	
		Hrubovací 45°	3 & 4 & 5	Ø 4,0 - 20,0 str. 28	
Toroidní			2	Ø 0,4 - 12,0 str. 29 - 30	
			4	Ø 1,0 - 16,0 str. 31 - 32	

2HRBG 2-břité KULOVÉ frézy pro žebrování pro široký sortiment ocelí do HRC 52

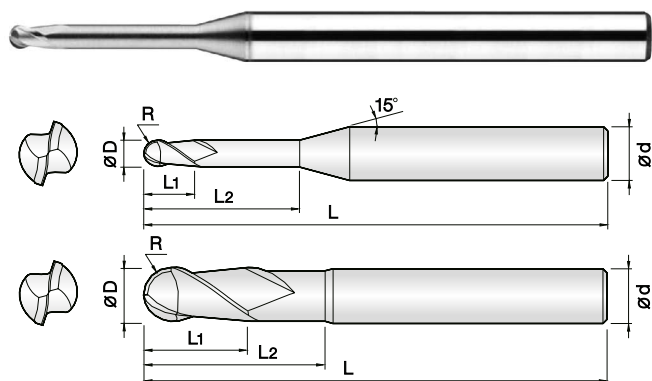

- Určeno pro široký sortiment různých typů ocelí do HRC 52
- Optimální pro různé typy ocelí díky AlCrN povlaku
- Velmi přesné tolerance řezných hran
- Široký sortiment vyložení pro optimální výběr nástroje
- Minimalizace vyštipování díky tvrdokovu s vysokou houževnatostí

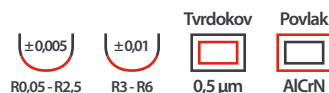
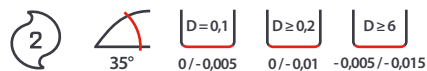

Objednací číslo	D (mm)	R (mm)	L2 (mm)	L1 (mm)	L (mm)	d h5 (mm)	Standardní položka
2HRBG-001-003-S04	0,1	R0,05	-	0,3	40	4	☑
2HRBG-001-005-S04			-	0,5	40	4	☑
2HRBG-002-005-S04	0,2	R0,1	0,5	0,2	40	4	☑
2HRBG-002-010-S04			1	0,2	40	4	☑
2HRBG-002-015-S04			1,5	0,2	40	4	☑
2HRBG-002-020-S04			2	0,2	40	4	☑
2HRBG-003-010-S04	0,3	R0,15	1	0,3	40	4	☑
2HRBG-003-015-S04			1,5	0,3	40	4	☑
2HRBG-003-020-S04			2	0,3	40	4	☑
2HRBG-003-030-S04			3	0,3	40	4	☑
2HRBG-003-040-S04			4	0,3	40	4	☑
2HRBG-003-050-S04			5	0,3	40	4	☑
2HRBG-004-010-S04	0,4	R0,2	1	0,5	40	4	☑
2HRBG-004-020-S04			2	0,5	40	4	☑
2HRBG-004-030-S04			3	0,5	40	4	☑
2HRBG-004040-S04			4	0,5	40	4	☑
2HRBG-004-050-S04			5	0,5	40	4	☑
2HRBG-004-060-S04			6	0,5	40	4	☑
2HRBG-004-080-S04	0,5	R0,25	8	0,5	40	4	☑
2HRBG-004-100-S04			10	0,5	40	4	☑
2HRBG-005-010-S04			1	0,6	45	4	☑
2HRBG-005-020-S04			2	0,6	45	4	☑
2HRBG-005-030-S04			3	0,6	45	4	☑
2HRBG-005-040-S04			4	0,6	45	4	☑
2HRBG-005-050-S04			5	0,6	45	4	☑
2HRBG-005-060-S04			6	0,6	45	4	☑
2HRBG-005-080-S04			8	0,6	45	4	☑
2HRBG-005-100-S04			10	0,6	45	4	☑
2HRBG-005-120-S04	0,6	R0,3	12	0,6	45	4	☑
2HRBG-005-140-S04			14	0,6	45	4	☑
2HRBG-006-010-S04			1	0,7	45	4	☑
2HRBG-006-020-S04			2	0,7	45	4	☑
2HRBG-006-030-S04			3	0,7	45	4	☑
2HRBG-006-040-S04			4	0,7	45	4	☑
2HRBG-006-050-S04			5	0,7	45	4	☑
2HRBG-006-060-S04			6	0,7	45	4	☑
2HRBG-006-080-S04			8	0,7	45	4	☑
2HRBG-006-100-S04			10	0,7	45	4	☑

Objednací číslo	D (mm)	R (mm)	L2 (mm)	L1 (mm)	L (mm)	d h5 (mm)	Standardní položka
2HRBG-006-120-S04	0,6	R0,3	12	0,7	45	4	☑
2HRBG-006-140-S04			14	0,7	45	4	☑
2HRBG-006-160-S04			16	0,7	45	4	☑
2HRBG-007-020-S04	0,7	R0,35	2	0,8	45	4	☑
2HRBG-007-040-S04			4	0,8	45	4	☑
2HRBG-007-080-S04			8	0,8	45	4	☑
2HRBG-007-100-S04			10	0,8	45	4	☑
2HRBG-007-120-S04			12	0,8	45	4	☑
2HRBG-008-020-S04	0,8	R0,4	2	0,9	45	4	☑
2HRBG-008-040-S04			4	0,9	45	4	☑
2HRBG-008-060-S04			6	0,9	45	4	☑
2HRBG-008-080-S04			8	0,9	45	4	☑
2HRBG-008-100-S04			10	0,9	45	4	☑
2HRBG-008-120-S04			12	0,9	45	4	☑
2HRBG-008-140-S04			14	0,9	45	4	☑
2HRBG-008-160-S04	16	0,9	45	4	☑		
2HRBG-009-040-S04	0,9	R0,45	4	1	45	4	☑
2HRBG-010-020-S04	1	R0,5	2	1,2	45	4	☑
2HRBG-010-020-S06			2	1,2	45	6	☑
2HRBG-010-030-S04			3	1,2	45	4	☑
2HRBG-010-030-S06			3	1,2	45	6	☑
2HRBG-010-040-S04			4	1,2	45	4	☑
2HRBG-010-040-S06			4	1,2	45	6	☑
2HRBG-010-050-S04			5	1,2	45	4	☑
2HRBG-010-050-S06			5	1,2	45	6	☑
2HRBG-010-060-S04			6	1,2	45	4	☑
2HRBG-010-060-S06			6	1,2	45	6	☑
2HRBG-010-080-S04			8	1,2	45	4	☑
2HRBG-010-080-S06			8	1,2	45	6	☑
2HRBG-010-100-S04			10	1,2	50	4	☑
2HRBG-010-100-S06			10	1,2	50	6	☑
2HRBG-010-120-S04			12	1,2	50	4	☑
2HRBG-010-120-S06			12	1,2	50	6	☑
2HRBG-010-140-S04			14	1,2	50	4	☑
2HRBG-010-140-S06			14	1,2	50	6	☑
2HRBG-010-160-S04			16	1,2	50	4	☑
2HRBG-010-160-S06			16	1,2	55	6	☑
2HRBG-010-180-S04	18	1,2	50	4	☑		

2HRBG

2-břité KULOVÉ frézy pro žebrování pro široký sortiment ocelí do HRC 52

Objednací číslo	D (mm)	R (mm)	L2 (mm)	L1 (mm)	L (mm)	d h5 (mm)	Standardní položka		
2HRBG-010-180-S06	1	R0,5	18	1,2	60	6	☑		
2HRBG-010-200-S04			20	1,2	50	4	☑		
2HRBG-010-200-S06			20	1,2	60	6	☑		
2HRBG-010-220-S04			22	1,2	60	4	☑		
2HRBG-010-220-S06			22	1,2	65	6	☑		
2HRBG-010-250-S04			25	1,2	60	4	☑		
2HRBG-012-040-S04			1,2	R0,6	4	1,4	45	4	☑
2HRBG-012-040-S06	4	1,4			45	6	☑		
2HRBG-012-060-S04	6	1,4			45	4	☑		
2HRBG-012-060-S06	6	1,4			45	6	☑		
2HRBG-012-080-S04	8	1,4			45	4	☑		
2HRBG-012-080-S06	8	1,4			45	6	☑		
2HRBG-012-100-S04	10	1,4			50	4	☑		
2HRBG-012-100-S06	10	1,4			50	6	☑		
2HRBG-012-120-S04	12	1,4			50	4	☑		
2HRBG-012-120-S06	12	1,4			50	6	☑		
2HRBG-012-160-S04	16	1,4			50	4	☑		
2HRBG-012-160-S06	16	1,4			55	6	☑		
2HRBG-012-200-S04	20	1,4			50	4	☑		
2HRBG-012-200-S06	20	1,4			60	6	☑		
2HRBG-012-240-S04	24	1,4			60	4	☑		
2HRBG-012-240-S06	24	1,4			65	6	☑		
2HRBG-014-060-S04	1,4	R0,7			6	1,6	45	4	☑
2HRBG-014-080-S04					8	1,6	45	4	☑
2HRBG-014-120-S04			12	1,6	50	4	☑		
2HRBG-014-160-S04			16	1,6	50	4	☑		
2HRBG-015-030-S04	1,5	R0,75	3	1,8	45	4	☑		
2HRBG-015-030-S06			3	1,8	45	6	☑		
2HRBG-015-040-S04			4	1,8	45	4	☑		
2HRBG-015-040-S06			4	1,8	45	6	☑		
2HRBG-015-060-S04			6	1,8	45	4	☑		
2HRBG-015-060-S06			6	1,8	45	6	☑		
2HRBG-015-080-S04			8	1,8	45	4	☑		
2HRBG-015-080-S06			8	1,8	45	6	☑		
2HRBG-015-100-S04			10	1,8	50	4	☑		
2HRBG-015-100-S06			10	1,8	50	6	☑		
2HRBG-015-120-S04			12	1,8	50	4	☑		
2HRBG-015-120-S06			12	1,8	50	6	☑		
2HRBG-015-140-S04			14	1,8	50	4	☑		
2HRBG-015-140-S06			14	1,8	50	6	☑		
2HRBG-015-160-S04			16	1,8	50	4	☑		
2HRBG-015-160-S06			16	1,8	55	6	☑		
2HRBG-015-180-S04			18	1,8	50	4	☑		
2HRBG-015-180-S06			18	1,8	60	6	☑		
2HRBG-015-200-S04			20	1,8	50	4	☑		
2HRBG-015-200-S06			20	1,8	60	6	☑		
2HRBG-015-220-S04			22	1,8	60	4	☑		
2HRBG-015-220-S06			22	1,8	65	6	☑		
2HRBG-015-250-S04			25	1,8	60	4	☑		
2HRBG-015-250-S06			25	1,8	65	6	☑		
2HRBG-015-300-S04			30	1,8	70	4	☑		
2HRBG-015-300-S06			30	1,8	70	6	☑		

Objednací číslo	D (mm)	R (mm)	L2 (mm)	L1 (mm)	L (mm)	d h5 (mm)	Standardní položka
2HRBG-015-350-S04	1,5	R0,75	35	1,8	70	4	☑
2HRBG-016-060-S04	1,6	R0,8	6	1,9	45	4	☑
2HRBG-016-080-S04			8	1,9	45	4	☑
2HRBG-016-120-S04			12	1,9	50	4	☑
2HRBG-016-160-S04			16	1,9	50	4	☑
2HRBG-016-200-S04			20	1,9	50	4	☑
2HRBG-018-060-S04			1,8	R0,9	6	2,1	45
2HRBG-018-080-S04	8	2,1			45	4	☑
2HRBG-018-120-S04	12	2,1			50	4	☑
2HRBG-018-160-S04	16	2,1			50	4	☑
2HRBG-018-200-S04	20	2,1			50	4	☑
2HRBG-020-040-S04	2	R1			4	2,4	45
2HRBG-020-040-S06			4	2,4	45	6	☑
2HRBG-020-060-S04			6	2,4	45	4	☑
2HRBG-020-060-S06			6	2,4	45	6	☑
2HRBG-020-080-S04			8	2,4	45	4	☑
2HRBG-020-080-S06			8	2,4	45	6	☑
2HRBG-020-100-S04			10	2,4	50	4	☑
2HRBG-020-100-S06			10	2,4	50	6	☑
2HRBG-020-120-S04			12	2,4	50	4	☑
2HRBG-020-120-S06			12	2,4	50	6	☑
2HRBG-020-140-S04			14	2,4	50	4	☑
2HRBG-020-140-S06			14	2,4	50	6	☑
2HRBG-020-160-S04			16	2,4	50	4	☑
2HRBG-020-160-S06			16	2,4	55	6	☑
2HRBG-020-180-S04			18	2,4	50	4	☑
2HRBG-020-180-S06			18	2,4	60	6	☑
2HRBG-020-200-S04			20	2,4	50	4	☑
2HRBG-020-200-S06			20	2,4	60	6	☑
2HRBG-020-220-S04			22	2,4	60	4	☑
2HRBG-020-220-S06			22	2,4	65	6	☑
2HRBG-020-250-S04			25	2,4	60	4	☑
2HRBG-020-250-S06			25	2,4	65	6	☑
2HRBG-020-300-S04			30	2,4	70	4	☑
2HRBG-020-300-S06			30	2,4	70	6	☑
2HRBG-020-350-S04	35	2,4	70	4	☑		
2HRBG-020-350-S06	35	2,4	75	6	☑		
2HRBG-020-400-S04	40	2,4	80	4	☑		
2HRBG-020-400-S06	40	2,4	80	6	☑		
2HRBG-020-450-S04	45	2,4	80	4	☑		
2HRBG-025-080-S04	2,5	R1,25	8	3	45	4	☑
2HRBG-025-100-S04			10	3	50	4	☑
2HRBG-025-160-S04			16	3	50	4	☑
2HRBG-025-200-S04			20	3	50	4	☑
2HRBG-025-250-S04			25	3	60	4	☑
2HRBG-025-300-S04			30	3	70	4	☑
2HRBG-025-350-S04			35	3	70	4	☑
2HRBG-030-060-S06	3	R1,5	6	3,6	45	6	☑
2HRBG-030-080-S06			8	3,6	45	6	☑
2HRBG-030-100-S06			10	3,6	50	6	☑
2HRBG-030-120-S06			12	3,6	50	6	☑
2HRBG-030-160-S06			16	3,6	55	6	☑

2HRBG

2-břité KULOVÉ frézy pro žebrování pro široký sortiment ocelí do HRC 52

Objednací číslo	D (mm)	R (mm)	L2 (mm)	L1 (mm)	L (mm)	d h5 (mm)	Standardní položka		
2HRBG-030-200-S06	3	R1,5	20	3,6	60	6	<input checked="" type="checkbox"/>		
2HRBG-030-250-S06			25	3,6	65	6	<input checked="" type="checkbox"/>		
2HRBG-030-300-S06			30	3,6	70	6	<input checked="" type="checkbox"/>		
2HRBG-030-350-S06			35	3,6	75	6	<input checked="" type="checkbox"/>		
2HRBG-030-400-S06			40	3,6	80	6	<input checked="" type="checkbox"/>		
2HRBG-030-450-S06			45	3,6	90	6	<input checked="" type="checkbox"/>		
2HRBG-030-500-S06			50	3,6	100	6	<input checked="" type="checkbox"/>		
2HRBG-030-600-S06			60	3,6	100	6	<input checked="" type="checkbox"/>		
2HRBG-040-080-S06	4	R2	8	4,8	45	6	<input checked="" type="checkbox"/>		
2HRBG-040-100-S06			10	4,8	50	6	<input checked="" type="checkbox"/>		
2HRBG-040-120-S06			12	4,8	50	6	<input checked="" type="checkbox"/>		
2HRBG-040-160-S06			16	4,8	55	6	<input checked="" type="checkbox"/>		
2HRBG-040-200-S06			20	4,8	60	6	<input checked="" type="checkbox"/>		
2HRBG-040-250-S06			25	4,8	65	6	<input checked="" type="checkbox"/>		
2HRBG-040-300-S06			30	4,8	70	6	<input checked="" type="checkbox"/>		
2HRBG-040-350-S06			35	4,8	75	6	<input checked="" type="checkbox"/>		
2HRBG-040-400-S06			40	4,8	80	6	<input checked="" type="checkbox"/>		
2HRBG-040-450-S06			45	4,8	90	6	<input checked="" type="checkbox"/>		
2HRBG-040-500-S06			50	4,8	100	6	<input checked="" type="checkbox"/>		
2HRBG-040-550-S06			55	4,8	100	6	<input checked="" type="checkbox"/>		
2HRBG-040-600-S06			60	4,8	100	6	<input checked="" type="checkbox"/>		
2HRBG-050-150-S06			5	R2,5	15	6	55	6	<input checked="" type="checkbox"/>
2HRBG-050-200-S06					20	6	60	6	<input checked="" type="checkbox"/>
2HRBG-050-250-S06					25	6	70	6	<input checked="" type="checkbox"/>
2HRBG-050-300-S06	30	6			75	6	<input checked="" type="checkbox"/>		
2HRBG-050-400-S06	40	6			80	6	<input checked="" type="checkbox"/>		
2HRBG-050-450-S06	45	6			90	6	<input checked="" type="checkbox"/>		
2HRBG-050-500-S06	50	6			100	6	<input checked="" type="checkbox"/>		
2HRBG-050-600-S06	60	6			100	6	<input checked="" type="checkbox"/>		
2HRBG-060-150-S06	6	R3	15	10	55	6	<input checked="" type="checkbox"/>		
2HRBG-060-300-S06			30	10	110	6	<input checked="" type="checkbox"/>		
2HRBG-080-250-060	8	R4	25	12	60	8	<input checked="" type="checkbox"/>		
2HRBG-080-300-100			30	12	100	8	<input checked="" type="checkbox"/>		
2HRBG-100-300-070	10	R5	30	16	70	10	<input checked="" type="checkbox"/>		
2HRBG-100-350-100			35	16	100	10	<input checked="" type="checkbox"/>		
2HRBG-120-300-075	12	R6	30	18	75	12	<input checked="" type="checkbox"/>		
2HRBG-120-400-110			40	18	110	12	<input checked="" type="checkbox"/>		

2HREG 2-břité OSTRÉ frézy pro žebrování pro široký sortiment ocelí do HRC 52

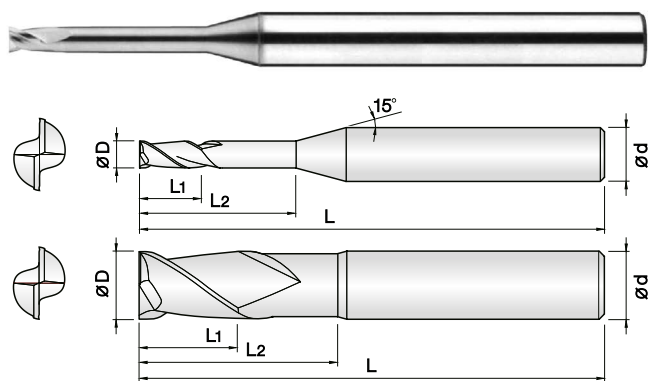

- ▶ Určeno pro široký sortiment různých typů ocelí do HRC 52
- ▶ Optimální pro různé typy ocelí díky AlCrN povlaku
- ▶ Velmi přesné tolerance rezných hran
- ▶ Široký sortiment vyložení pro optimální výběr nástroje
- ▶ Minimalizace vyštipování díky tvrdokovu s vysokou houževnatostí

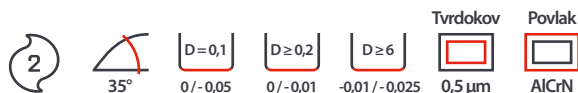

Objednací číslo	D (mm)	L2 (mm)	L1 (mm)	L (mm)	d h5 (mm)	Standardní položka
2HREG-001-003-S04	0,1	-	0,3	40	4	☑
2HREG-001-005-S04		-	0,5	40	4	☑
2HREG-002-005-S04	0,2	0,5	0,3	40	4	☑
2HREG-002-010-S04		1	0,2	40	4	☑
2HREG-002-015-S04		1,5	0,2	40	4	☑
2HREG-002-020-S04		2	0,2	40	4	☑
2HREG-003-010-S04	0,3	1	0,3	40	4	☑
2HREG-003-015-S04		1,5	0,3	40	4	☑
2HREG-003-020-S04		2	0,3	40	4	☑
2HREG-003-030-S04		3	0,3	40	4	☑
2HREG-003-040-S04		4	0,3	40	4	☑
2HREG-003-050-S04	0,4	5	0,3	40	4	☑
2HREG-004-010-S04		1	0,5	40	4	☑
2HREG-004-020-S04		2	0,5	40	4	☑
2HREG-004-030-S04		3	0,5	40	4	☑
2HREG-004-040-S04		4	0,5	40	4	☑
2HREG-004-050-S04		5	0,5	40	4	☑
2HREG-004-060-S04		6	0,5	40	4	☑
2HREG-004-080-S04	0,5	8	0,5	40	4	☑
2HREG-004-100-S04		10	0,5	40	4	☑
2HREG-005-020-S04		2	0,6	45	4	☑
2HREG-005-030-S04		3	0,6	45	4	☑
2HREG-005-040-S04		4	0,6	45	4	☑
2HREG-005-050-S04		5	0,6	45	4	☑
2HREG-005-060-S04		6	0,6	45	4	☑
2HREG-005-080-S04		8	0,6	45	4	☑
2HREG-005-100-S04		10	0,6	45	4	☑
2HREG-005-120-S04		12	0,6	45	4	☑
2HREG-005-140-S04	14	0,6	45	4	☑	
2HREG-006-020-S04	0,6	2	0,7	45	4	☑
2HREG-006-030-S04		3	0,7	45	4	☑
2HREG-006-040-S04		4	0,7	45	4	☑
2HREG-006-050-S04		5	0,7	45	4	☑
2HREG-006-060-S04		6	0,7	45	4	☑
2HREG-006-080-S04		8	0,7	45	4	☑
2HREG-006-100-S04		10	0,7	45	4	☑
2HREG-006-120-S04		12	0,7	45	4	☑
2HREG-006-140-S04		14	0,7	45	4	☑

Objednací číslo	D (mm)	L2 (mm)	L1 (mm)	L (mm)	d h5 (mm)	Standardní položka	
2HREG-006-160-S04	0,6	16	0,7	45	4	☑	
2HREG-007-020-S04	0,7	2	0,8	45	4	☑	
2HREG-007-040-S04		4	0,8	45	4	☑	
2HREG-007-060-S04		6	0,8	45	4	☑	
2HREG-007-080-S04		8	0,8	45	4	☑	
2HREG-007-100-S04		10	0,8	45	4	☑	
2HREG-007-120-S04	0,8	12	0,8	45	4	☑	
2HREG-008-020-S04		2	0,9	45	4	☑	
2HREG-008-040-S04		4	0,9	45	4	☑	
2HREG-008-060-S04		6	0,9	45	4	☑	
2HREG-008-080-S04		8	0,9	45	4	☑	
2HREG-008-100-S04	0,9	10	0,9	45	4	☑	
2HREG-008-120-S04		12	0,9	45	4	☑	
2HREG-008-140-S04		14	0,9	45	4	☑	
2HREG-009-060-S04		6	1	45	4	☑	
2HREG-009-080-S04		8	1	45	4	☑	
2HREG-009-100-S04	1	10	1	45	4	☑	
2HREG-010-020-S04		2	1,2	45	4	☑	
2HREG-010-030-S04		3	1,2	45	4	☑	
2HREG-010-040-S04		4	1,2	45	4	☑	
2HREG-010-050-S04		5	1,2	45	4	☑	
2HREG-010-060-S04		6	1,2	45	4	☑	
2HREG-010-080-S04		8	1,2	45	4	☑	
2HREG-010-100-S04		10	1,2	50	4	☑	
2HREG-010-120-S04		12	1,2	50	4	☑	
2HREG-010-140-S04		14	1,2	50	4	☑	
2HREG-010-160-S04	1,2	16	1,2	50	4	☑	
2HREG-010-180-S04		18	1,2	50	4	☑	
2HREG-010-200-S04		20	1,2	50	4	☑	
2HREG-010-250-S04		25	1,2	60	4	☑	
2HREG-010-300-S04		30	1,2	70	4	☑	
2HREG-012-040-S04		1,2	4	1,4	45	4	☑
2HREG-012-060-S04			6	1,4	45	4	☑
2HREG-012-080-S04			8	1,4	45	4	☑
2HREG-012-100-S04			10	1,4	50	4	☑
2HREG-012-120-S04			12	1,4	50	4	☑
2HREG-012-160-S04	16		1,4	50	4	☑	
2HREG-012-200-S04	20		1,4	50	4	☑	

2HREG

2-břité OSTRÉ frézy pro žebrování pro široký sortiment ocelí do HRC 52

Objednací číslo	D (mm)	L2 (mm)	L1 (mm)	L (mm)	d h5 (mm)	Standardní položka	
2HREG-012-250-S04	1,2	25	1,4	60	4	☑	
2HREG-012-300-S04		30	1,4	70	4	☑	
2HREG-014-060-S04	1,4	6	1,6	45	4	☑	
2HREG-014-080-S04		8	1,6	45	4	☑	
2HREG-014-100-S04		10	1,6	50	4	☑	
2HREG-014-140-S04		14	1,6	50	4	☑	
2HREG-014-160-S04		16	1,6	50	4	☑	
2HREG-014-200-S04		20	1,6	50	4	☑	
2HREG-015-040-S04		1,5	4	1,8	45	4	☑
2HREG-015-060-S04	6		1,8	45	4	☑	
2HREG-015-080-S04	8		1,8	45	4	☑	
2HREG-015-100-S04	10		1,8	50	4	☑	
2HREG-015-120-S04	12		1,8	50	4	☑	
2HREG-015-140-S04	14		1,8	50	4	☑	
2HREG-015-160-S04	16		1,8	50	4	☑	
2HREG-015-180-S04	18		1,8	50	4	☑	
2HREG-015-200-S04	20		1,8	50	4	☑	
2HREG-015-250-S04	25		1,8	60	4	☑	
2HREG-015-300-S04	30		1,8	70	4	☑	
2HREG-016-100-S04	1,6		10	1,9	50	4	☑
2HREG-016-140-S04			14	1,9	50	4	☑
2HREG-016-180-S04			18	1,9	50	4	☑
2HREG-018-100-S04	1,8		10	2,1	50	4	☑
2HREG-018-140-S04		14	2,1	50	4	☑	
2HREG-018-180-S04		18	2,1	50	4	☑	
2HREG-020-040-S04	2	4	2,4	45	4	☑	
2HREG-020-060-S04		6	2,4	45	4	☑	
2HREG-020-080-S04		8	2,4	45	4	☑	
2HREG-020-100-S04		10	2,4	50	4	☑	
2HREG-020-120-S04		12	2,4	50	4	☑	
2HREG-020-140-S04		14	2,4	50	4	☑	
2HREG-020-160-S04		16	2,4	50	4	☑	
2HREG-020-180-S04		18	2,4	50	4	☑	
2HREG-020-200-S04		20	2,4	50	4	☑	
2HREG-020-220-S04		22	2,4	60	4	☑	
2HREG-020-250-S04		25	2,4	60	4	☑	
2HREG-020-300-S04		30	2,4	70	4	☑	
2HREG-020-350-S04		35	2,4	70	4	☑	
2HREG-020-400-S04		40	2,4	80	4	☑	
2HREG-020-450-S04		45	2,4	80	4	☑	
2HREG-020-500-S04		50	2,4	90	4	☑	
2HREG-025-080-S04		2,5	8	3	45	4	☑
2HREG-025-100-S04			10	3	50	4	☑
2HREG-025-120-S04	12		3	50	4	☑	
2HREG-025-160-S04	16		3	50	4	☑	
2HREG-025-200-S04	20		3	50	4	☑	
2HREG-025-250-S04	25		3	60	4	☑	
2HREG-025-300-S04	30		3	70	4	☑	
2HREG-025-350-S04	35		3	70	4	☑	
2HREG-025-400-S04	40		3	80	4	☑	
2HREG-025-500-S04	50		3	90	4	☑	
2HREG-030-060-S06	3	6	3,6	45	6	☑	

Objednací číslo	D (mm)	L2 (mm)	L1 (mm)	L (mm)	d h5 (mm)	Standardní položka	
2HREG-030-080-S06	3	8	3,6	45	6	☑	
2HREG-030-100-S06		10	3,6	50	6	☑	
2HREG-030-120-S06		12	3,6	50	6	☑	
2HREG-030-160-S06		16	3,6	55	6	☑	
2HREG-030-200-S06		20	3,6	60	6	☑	
2HREG-030-250-S06		25	3,6	65	6	☑	
2HREG-030-300-S06		30	3,6	70	6	☑	
2HREG-030-350-S06		35	3,6	75	6	☑	
2HREG-030-400-S06		40	3,6	80	6	☑	
2HREG-030-450-S06		45	3,6	90	6	☑	
2HREG-030-500-S06		50	3,6	100	6	☑	
2HREG-030-600-S06		60	3,6	100	6	☑	
2HREG-040-080-S06	4	8	4,8	45	6	☑	
2HREG-040-100-S06		10	4,8	50	6	☑	
2HREG-040-120-S06		12	4,8	50	6	☑	
2HREG-040-160-S06		16	4,8	55	6	☑	
2HREG-040-200-S06		20	4,8	60	6	☑	
2HREG-040-250-S06		25	4,8	65	6	☑	
2HREG-040-300-S06		30	4,8	70	6	☑	
2HREG-040-350-S06		35	4,8	75	6	☑	
2HREG-040-400-S06		40	4,8	80	6	☑	
2HREG-040-450-S06		45	4,8	90	6	☑	
2HREG-040-500-S06		50	4,8	100	6	☑	
2HREG-040-550-S06		55	4,8	100	6	☑	
2HREG-040-600-S06		60	4,8	100	6	☑	
2HREG-050-150-S06		5	15	6	55	6	☑
2HREG-050-200-S06			20	6	60	6	☑
2HREG-050-250-S06			25	6	70	6	☑
2HREG-050-300-S06			30	6	75	6	☑
2HREG-050-350-S06			35	6	75	6	☑
2HREG-050-400-S06	40		6	80	6	☑	
2HREG-050-500-S06	6	50	6	100	6	☑	
2HREG-050-600-S06		60	6	100	6	☑	
2HREG-060-200-S06		20	10	60	6	☑	
2HREG-060-300-S06		30	10	75	6	☑	
2HREG-060-400-S06		40	10	80	6	☑	
2HREG-060-500-S06		50	10	90	6	☑	
2HREG-060-600-S06	8	60	10	110	6	☑	
2HREG-080-200-S08		20	12	65	8	☑	
2HREG-080-300-S08		30	12	80	8	☑	
2HREG-080-400-S08	10	40	12	100	8	☑	
2HREG-100-250-S10		25	15	70	10	☑	
2HREG-100-350-S10		35	15	80	10	☑	
2HREG-100-450-S10	12	45	15	100	10	☑	
2HREG-120-300-S12		30	18	80	12	☑	
2HREG-120-400-S12		40	18	100	12	☑	
2HREG-120-500-S12	50	18	120	12	☑		

4HREG 4-břité OSTRÉ frézy pro žebrování pro široký sortiment ocelí do HRC 52

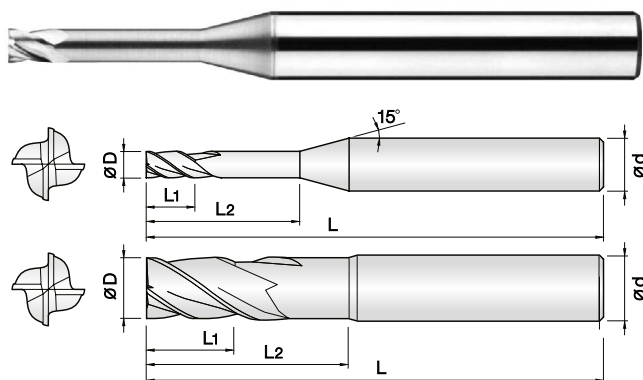

- ▶ Určeno pro široký sortiment různých typů ocelí do HRC 52
- ▶ Optimální pro různé typy ocelí díky AlCrN povlaku
- ▶ Velmi přesné tolerance rezných hran
- ▶ Široký sortiment vyložení pro optimální výběr nástroje
- ▶ Minimalizace vyštipování díky tvrdokovu s vysokou houževnatostí



Objednací číslo	D (mm)	L2 (mm)	L1 (mm)	L (mm)	d h5 (mm)	Standardní položka
4HREG-008-020-S04	0,8	2	0,9	45	4	☑
4HREG-008-040-S04		4	0,9	45	4	☑
4HREG-008-060-S04		6	0,9	45	4	☑
4HREG-008-080-S04		8	0,9	45	4	☑
4HREG-008-100-S04		10	0,9	45	4	☑
4HREG-008-120-S04		12	0,9	45	4	☑
4HREG-008-160-S04		16	0,9	45	4	☑
4HREG-009-020-S04		0,9	2	1	45	4
4HREG-009-060-S04	6		1	45	4	☑
4HREG-009-080-S04	8		1	45	4	☑
4HREG-009-100-S04	10		1	45	4	☑
4HREG-010-030-S04	1	3	1,2	45	4	☑
4HREG-010-040-S04		4	1,2	45	4	☑
4HREG-010-060-S04		6	1,2	45	4	☑
4HREG-010-080-S04		8	1,2	45	4	☑
4HREG-010-100-S04		10	1,2	50	4	☑
4HREG-010-120-S04		12	1,2	50	4	☑
4HREG-010-160-S04		16	1,2	50	4	☑
4HREG-010-200-S04		20	1,2	50	4	☑
4HREG-010-250-S04	25	1,2	60	4	☑	
4HREG-012-060-S04	1,2	6	1,4	45	4	☑
4HREG-012-080-S04		8	1,4	45	4	☑
4HREG-012-100-S04		10	1,4	50	4	☑
4HREG-012-120-S04		12	1,4	50	4	☑
4HREG-012-160-S04		16	1,4	50	4	☑
4HREG-015-060-S04	1,5	6	1,8	45	4	☑
4HREG-015-080-S04		8	1,8	45	4	☑
4HREG-015-100-S04		10	1,8	50	4	☑
4HREG-015-120-S04		12	1,8	50	4	☑
4HREG-015-160-S04		16	1,8	50	4	☑
4HREG-015-200-S04		20	1,8	50	4	☑
4HREG-015-250-S04	25	1,8	60	4	☑	
4HREG-020-060-S04	2	6	2,4	45	4	☑
4HREG-020-080-S04		8	2,4	45	4	☑
4HREG-020-100-S04		10	2,4	50	4	☑
4HREG-020-120-S04		12	2,4	50	4	☑
4HREG-020-160-S04		16	2,4	50	4	☑
4HREG-020-200-S04		20	2,4	50	4	☑

Objednací číslo	D (mm)	L2 (mm)	L1 (mm)	L (mm)	d h5 (mm)	Standardní položka
4HREG-020-250-S04	2	25	2,4	60	4	☑
4HREG-020-300-S04		30	2,4	70	4	☑
4HREG-025-100-S04	2,5	10	3	50	4	☑
4HREG-025-120-S04		12	3	50	4	☑
4HREG-025-160-S04		16	3	50	4	☑
4HREG-025-200-S04		20	3	50	4	☑
4HREG-025-250-S04		25	3	60	4	☑
4HREG-025-300-S04		30	3	70	4	☑
4HREG-030-100-S06	3	10	3,6	50	6	☑
4HREG-030-120-S06		12	3,6	50	6	☑
4HREG-030-160-S06		16	3,6	55	6	☑
4HREG-030-200-S06		20	3,6	60	6	☑
4HREG-030-250-S06		25	3,6	65	6	☑
4HREG-030-300-S06		30	3,6	70	6	☑
4HREG-030-350-S06		35	3,6	75	6	☑
4HREG-030-400-S06	40	3,6	80	6	☑	
4HREG-040-100-S06	4	10	4,8	50	6	☑
4HREG-040-120-S06		12	4,8	50	6	☑
4HREG-040-160-S06		16	4,8	55	6	☑
4HREG-040-200-S06		20	4,8	60	6	☑
4HREG-040-250-S06		25	4,8	65	6	☑
4HREG-040-300-S06		30	4,8	70	6	☑
4HREG-040-400-S06		40	4,8	80	6	☑
4HREG-040-450-S06	45	4,8	90	6	☑	
4HREG-040-500-S06	50	4,8	100	6	☑	
4HREG-050-150-S06	5	15	6	55	6	☑
4HREG-050-200-S06		20	6	60	6	☑
4HREG-050-250-S06		25	6	65	6	☑
4HREG-050-300-S06		30	6	70	6	☑
4HREG-050-400-S06		40	6	80	6	☑
4HREG-050-500-S06	50	6	100	6	☑	
4HREG-060-200-S06	6	20	10	60	6	☑
4HREG-060-300-S06		30	10	75	6	☑
4HREG-060-400-S06		40	10	80	6	☑
4HREG-060-500-S06		50	10	90	6	☑
4HREG-080-200-S08	8	20	12	65	8	☑
4HREG-080-300-S08		30	12	80	8	☑
4HREG-080-400-S08		40	12	100	8	☑

4HREG

4-břité OSTRÉ frézy pro žebrování pro široký sortiment ocelí do HRC 52

Objednací číslo	D (mm)	L2 (mm)	L1 (mm)	L (mm)	d h5 (mm)	Standardní položka
4HREG-100-250-S10	10	25	15	70	10	<input checked="" type="checkbox"/>
4HREG-100-350-S10		35	15	90	10	<input checked="" type="checkbox"/>
4HREG-100-450-S10		45	15	110	10	<input checked="" type="checkbox"/>
4HREG-120-300-S12	12	30	18	80	12	<input checked="" type="checkbox"/>
4HREG-120-400-S12		40	18	100	12	<input checked="" type="checkbox"/>
4HREG-120-500-S12		50	18	120	12	<input checked="" type="checkbox"/>

2CREG

2-břité TOROIDNÍ frézy pro žebrování pro široký sortiment ocelí do HRC 52

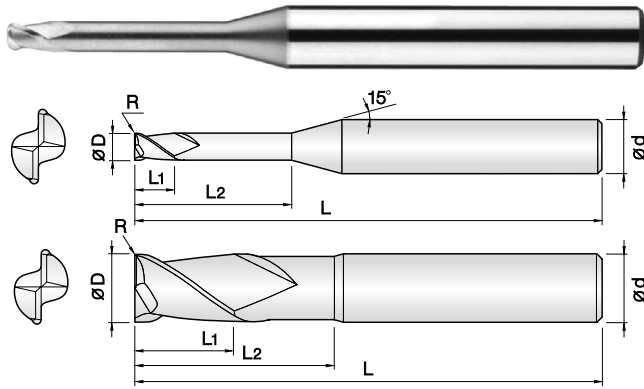

- Určeno pro široký sortiment různých typů ocelí do HRC 52
- Optimální pro různé typy ocelí díky AlCrN povlaku
- Velmi přesné tolerance řezných hran
- Široký sortiment vyložení a rádií pro optimální výběr nástroje
- Minimalizace vyštipování díky tvrdokovu s vysokou houževnatostí

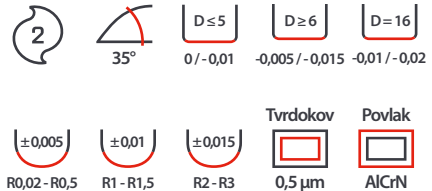

Objednací číslo	D (mm)	R (mm)	L2 (mm)	L1 (mm)	L (mm)	d h5 (mm)	Standardní položka	
2CREG-002-0002-010	0,2	R0,02	1	0,2	40	4	☑	
2CREG-002-0002-015			1,5	0,2	40	4	☑	
2CREG-002-0005-010		R0,05	1	0,2	40	4	☑	
2CREG-002-0005-015			1,5	0,2	40	4	☑	
2CREG-003-0005-010	0,3	R0,05	1	0,3	40	4	☑	
2CREG-003-0005-020			2	0,3	40	4	☑	
2CREG-003-0005-030			3	0,3	40	4	☑	
2CREG-004-0005-010	0,4	R0,05	1	0,5	40	4	☑	
2CREG-004-0005-020			2	0,5	40	4	☑	
2CREG-004-0005-030			3	0,5	40	4	☑	
2CREG-004-0005-040			4	0,5	40	4	☑	
2CREG-004-001-010		R0,1	1	0,5	40	4	☑	
2CREG-004-001-015			1,5	0,5	40	4	☑	
2CREG-004-001-020			2	0,5	40	4	☑	
2CREG-004-001-030			3	0,5	40	4	☑	
2CREG-004-001-040		4	0,5	40	4	☑		
2CREG-005-0005-010		0,5	R0,05	1	0,6	45	4	☑
2CREG-005-0005-015				1,5	0,6	45	4	☑
2CREG-005-0005-020				2	0,6	45	4	☑
2CREG-005-0005-025	2,5			0,6	45	4	☑	
2CREG-005-0005-030	3			0,6	45	4	☑	
2CREG-005-0005-040	4			0,6	45	4	☑	
2CREG-005-0005-050	5			0,6	45	4	☑	
2CREG-005-0005-060	6			0,6	45	4	☑	
2CREG-005-001-010	R0,1		1	0,6	45	4	☑	
2CREG-005-001-015			1,5	0,6	45	4	☑	
2CREG-005-001-020			2	0,6	45	4	☑	
2CREG-005-001-025			2,5	0,6	45	4	☑	
2CREG-005-001-030			3	0,6	45	4	☑	
2CREG-005-001-040			4	0,6	45	4	☑	
2CREG-005-001-050			5	0,6	45	4	☑	
2CREG-005-001-060			6	0,6	45	4	☑	
2CREG-006-0005-020	0,6	R0,05	2	0,7	45	4	☑	
2CREG-006-0005-030			3	0,7	45	4	☑	
2CREG-006-0005-040			4	0,7	45	4	☑	
2CREG-006-0005-060			6	0,7	45	4	☑	
2CREG-006-0005-080		R0,1	2	0,7	45	4	☑	
2CREG-006-001-020			2	0,7	45	4	☑	

Objednací číslo	D (mm)	R (mm)	L2 (mm)	L1 (mm)	L (mm)	d h5 (mm)	Standardní položka	
2CREG-006-001-030	0,6	R0,1	3	0,7	45	4	☑	
2CREG-006-001-040			4	0,7	45	4	☑	
2CREG-006-001-060			6	0,7	45	4	☑	
2CREG-006-001-080			8	0,7	45	4	☑	
2CREG-007-001-020	0,7	R0,1	2	0,8	45	4	☑	
2CREG-007-001-040			4	0,8	45	4	☑	
2CREG-007-001-060			6	0,8	45	4	☑	
2CREG-008-001-020	0,8	R0,1	2	0,9	45	4	☑	
2CREG-008-001-040			4	0,9	45	4	☑	
2CREG-008-001-060			6	0,9	45	4	☑	
2CREG-008-001-080			8	0,9	45	4	☑	
2CREG-008-002-020		R0,2	2	0,9	45	4	☑	
2CREG-008-002-040			4	0,9	45	4	☑	
2CREG-008-002-060			6	0,9	45	4	☑	
2CREG-008-002-080			8	0,9	45	4	☑	
2CREG-010-001-040		1	R0,1	4	1,2	45	4	☑
2CREG-010-001-060				6	1,2	45	4	☑
2CREG-010-001-080				8	1,2	45	4	☑
2CREG-010-001-100				10	1,2	50	4	☑
2CREG-010-001-120	12			1,2	50	4	☑	
2CREG-010-001-160	16			1,2	50	4	☑	
2CREG-010-001-200	20			1,2	50	4	☑	
2CREG-010-002-040	R0,2			4	1,2	45	4	☑
2CREG-010-002-060			6	1,2	45	4	☑	
2CREG-010-002-080			8	1,2	45	4	☑	
2CREG-010-002-100			10	1,2	50	4	☑	
2CREG-010-002-120			12	1,2	50	4	☑	
2CREG-010-002-160			16	1,2	50	4	☑	
2CREG-010-002-200			20	1,2	50	4	☑	
2CREG-010-003-040			R0,3	4	1,2	45	4	☑
2CREG-010-003-060	6			1,2	45	4	☑	
2CREG-010-003-080	8	1,2		45	4	☑		
2CREG-010-003-100	10	1,2		50	4	☑		
2CREG-010-003-120	12	1,2		50	4	☑		
2CREG-010-003-160	16	1,2		50	4	☑		
2CREG-010-003-200	20	1,2		50	4	☑		
2CREG-012-001-040	1,2	R0,1		4	1,4	45	4	☑
2CREG-012-001-060			6	1,4	45	4	☑	

2CREG

2-břité TOROIDNÍ frézy pro žebrování pro široký sortiment ocelí do HRC 52

Objednací číslo	D (mm)	R (mm)	L2 (mm)	L1 (mm)	L (mm)	d h5 (mm)	Standardní položka	
2CREG-012-001-080	1,2	R0,1	8	1,4	45	4	☑	
2CREG-012-001-100			10	1,4	50	4	☑	
2CREG-012-001-120			12	1,4	50	4	☑	
2CREG-012-001-160			16	1,4	50	4	☑	
2CREG-012-001-200			20	1,4	50	4	☑	
2CREG-012-002-040			R0,2	4	1,4	45	4	☑
2CREG-012-002-060		6		1,4	45	4	☑	
2CREG-012-002-080		8		1,4	45	4	☑	
2CREG-012-002-100		10		1,4	50	4	☑	
2CREG-012-002-120		12		1,4	50	4	☑	
2CREG-012-002-160		16		1,4	50	4	☑	
2CREG-012-002-200		20	1,4	50	4	☑		
2CREG-012-003-040		R0,3	4	1,4	45	4	☑	
2CREG-012-003-060			6	1,4	45	4	☑	
2CREG-012-003-080			8	1,4	45	4	☑	
2CREG-012-003-100			10	1,4	50	4	☑	
2CREG-012-003-120			12	1,4	50	4	☑	
2CREG-012-003-160			16	1,4	50	4	☑	
2CREG-012-003-200		20	1,4	50	4	☑		
2CREG-015-001-040		1,5	R0,1	4	1,8	45	4	☑
2CREG-015-001-060				6	1,8	45	4	☑
2CREG-015-001-080				8	1,8	45	4	☑
2CREG-015-001-100				10	1,8	50	4	☑
2CREG-015-001-120				12	1,8	50	4	☑
2CREG-015-001-160	16			1,8	50	4	☑	
2CREG-015-001-200	20		1,8	50	4	☑		
2CREG-015-001-220	22		1,8	60	4	☑		
2CREG-015-001-250	25		1,8	60	4	☑		
2CREG-015-002-040	R0,2		4	1,8	45	4	☑	
2CREG-015-002-060			6	1,8	45	4	☑	
2CREG-015-002-080			8	1,8	45	4	☑	
2CREG-015-002-100			10	1,8	50	4	☑	
2CREG-015-002-120			12	1,8	50	4	☑	
2CREG-015-002-160			16	1,8	50	4	☑	
2CREG-015-002-200	20		1,8	50	4	☑		
2CREG-015-002-220	22		1,8	60	4	☑		
2CREG-015-002-250	25		1,8	60	4	☑		
2CREG-015-003-040	R0,3		4	1,8	45	4	☑	
2CREG-015-003-060			6	1,8	45	4	☑	
2CREG-015-003-080			8	1,8	45	4	☑	
2CREG-015-003-100			10	1,8	50	4	☑	
2CREG-015-003-120			12	1,8	50	4	☑	
2CREG-015-003-160			16	1,8	50	4	☑	
2CREG-015-003-200	20		1,8	50	4	☑		
2CREG-015-003-220	22		1,8	60	4	☑		
2CREG-015-003-250	25		1,8	60	4	☑		
2CREG-015-005-040	R0,5		4	1,8	45	4	☑	
2CREG-015-005-060			6	1,8	45	4	☑	
2CREG-015-005-080			8	1,8	45	4	☑	
2CREG-015-005-100			10	1,8	50	4	☑	
2CREG-015-005-120			12	1,8	50	4	☑	
2CREG-015-005-160			16	1,8	50	4	☑	

Objednací číslo	D (mm)	R (mm)	L2 (mm)	L1 (mm)	L (mm)	d h5 (mm)	Standardní položka
2CREG-015-005-200	1,5	R0,5	20	1,8	50	4	☑
2CREG-015-005-220			22	1,8	60	4	☑
2CREG-015-005-250			25	1,8	60	4	☑
2CREG-020-001-060	2	R0,1	6	2,4	45	4	☑
2CREG-020-001-080			8	2,4	45	4	☑
2CREG-020-001-100			10	2,4	50	4	☑
2CREG-020-001-120			12	2,4	50	4	☑
2CREG-020-001-160			16	2,4	50	4	☑
2CREG-020-001-200			20	2,4	50	4	☑
2CREG-020-001-250		25	2,4	60	4	☑	
2CREG-020-001-300		30	2,4	70	4	☑	
2CREG-020-002-060		R0,2	6	2,4	45	4	☑
2CREG-020-002-080			8	2,4	45	4	☑
2CREG-020-002-100			10	2,4	50	4	☑
2CREG-020-002-120			12	2,4	50	4	☑
2CREG-020-002-160			16	2,4	50	4	☑
2CREG-020-002-200			20	2,4	50	4	☑
2CREG-020-002-250		25	2,4	60	4	☑	
2CREG-020-002-300		30	2,4	70	4	☑	
2CREG-020-003-060		R0,3	6	2,4	45	4	☑
2CREG-020-003-080			8	2,4	45	4	☑
2CREG-020-003-100			10	2,4	50	4	☑
2CREG-020-003-120			12	2,4	50	4	☑
2CREG-020-003-160			16	2,4	50	4	☑
2CREG-020-003-200			20	2,4	50	4	☑
2CREG-020-003-250		25	2,4	60	4	☑	
2CREG-020-003-300		30	2,4	70	4	☑	
2CREG-020-005-060	R0,5	6	2,4	45	4	☑	
2CREG-020-005-080		8	2,4	45	4	☑	
2CREG-020-005-100		10	2,4	50	4	☑	
2CREG-020-005-120		12	2,4	50	4	☑	
2CREG-020-005-160		16	2,4	50	4	☑	
2CREG-020-005-200		20	2,4	50	4	☑	
2CREG-020-005-250	25	2,4	60	4	☑		
2CREG-020-005-300	30	2,4	70	4	☑		
2CREG-025-001-100	2,5	R0,1	10	3	50	4	☑
2CREG-025-001-160			16	3	50	4	☑
2CREG-025-001-200			20	3	50	4	☑
2CREG-025-001-250		25	3	60	4	☑	
2CREG-025-001-300		30	3	70	4	☑	
2CREG-025-002-100		R0,2	10	3	50	4	☑
2CREG-025-002-160			16	3	50	4	☑
2CREG-025-002-200			20	3	50	4	☑
2CREG-025-002-250		25	3	60	4	☑	
2CREG-025-002-300		30	3	70	4	☑	
2CREG-025-003-100		R0,3	10	3	50	4	☑
2CREG-025-003-160			16	3	50	4	☑
2CREG-025-003-200			20	3	50	4	☑
2CREG-025-003-250		25	3	60	4	☑	
2CREG-025-003-300		30	3	70	4	☑	
2CREG-025-005-100		R0,5	10	3	50	4	☑
2CREG-025-005-160			16	3	50	4	☑
2CREG-025-005-200			20	3	50	4	☑
2CREG-025-005-250	25	3	60	4	☑		
2CREG-025-005-300	30	3	70	4	☑		

2CREG

2-břité TOROIDNÍ frézy pro žebrování pro široký sortiment ocelí do HRC 52

Objednací číslo	D (mm)	R (mm)	L2 (mm)	L1 (mm)	L (mm)	d h5 (mm)	Standardní položka	
2CREG-025-005-200	2,5	R0,5	20	3	50	4	<input checked="" type="checkbox"/>	
2CREG-025-005-250			25	3	60	4	<input checked="" type="checkbox"/>	
2CREG-025-005-300			30	3	70	4	<input checked="" type="checkbox"/>	
2CREG-030-001-100	3	R0,1	10	3,6	50	6	<input checked="" type="checkbox"/>	
2CREG-030-001-120			12	3,6	50	6	<input checked="" type="checkbox"/>	
2CREG-030-001-160			16	3,6	55	6	<input checked="" type="checkbox"/>	
2CREG-030-001-200			20	3,6	60	6	<input checked="" type="checkbox"/>	
2CREG-030-001-250			25	3,6	65	6	<input checked="" type="checkbox"/>	
2CREG-030-001-300			30	3,6	70	6	<input checked="" type="checkbox"/>	
2CREG-030-001-350			35	3,6	75	6	<input checked="" type="checkbox"/>	
2CREG-030-001-400			40	3,6	80	6	<input checked="" type="checkbox"/>	
2CREG-030-002-100		R0,2	10	3,6	50	6	<input checked="" type="checkbox"/>	
2CREG-030-002-120			12	3,6	50	6	<input checked="" type="checkbox"/>	
2CREG-030-002-160			16	3,6	55	6	<input checked="" type="checkbox"/>	
2CREG-030-002-200			20	3,6	60	6	<input checked="" type="checkbox"/>	
2CREG-030-002-250			25	3,6	65	6	<input checked="" type="checkbox"/>	
2CREG-030-002-300			30	3,6	70	6	<input checked="" type="checkbox"/>	
2CREG-030-002-350			35	3,6	75	6	<input checked="" type="checkbox"/>	
2CREG-030-002-400			40	3,6	80	6	<input checked="" type="checkbox"/>	
2CREG-030-003-100		R0,3	10	3,6	50	6	<input checked="" type="checkbox"/>	
2CREG-030-003-120			12	3,6	50	6	<input checked="" type="checkbox"/>	
2CREG-030-003-160			16	3,6	55	6	<input checked="" type="checkbox"/>	
2CREG-030-003-200			20	3,6	60	6	<input checked="" type="checkbox"/>	
2CREG-030-003-250			25	3,6	65	6	<input checked="" type="checkbox"/>	
2CREG-030-003-300			30	3,6	70	6	<input checked="" type="checkbox"/>	
2CREG-030-003-350			35	3,6	75	6	<input checked="" type="checkbox"/>	
2CREG-030-003-400			40	3,6	80	6	<input checked="" type="checkbox"/>	
2CREG-030-005-100	R0,5	10	3,6	50	6	<input checked="" type="checkbox"/>		
2CREG-030-005-120		12	3,6	50	6	<input checked="" type="checkbox"/>		
2CREG-030-005-160		16	3,6	55	6	<input checked="" type="checkbox"/>		
2CREG-030-005-200		20	3,6	60	6	<input checked="" type="checkbox"/>		
2CREG-030-005-250		25	3,6	65	6	<input checked="" type="checkbox"/>		
2CREG-030-005-300		30	3,6	70	6	<input checked="" type="checkbox"/>		
2CREG-030-005-350		35	3,6	75	6	<input checked="" type="checkbox"/>		
2CREG-030-005-400		40	3,6	80	6	<input checked="" type="checkbox"/>		
2CREG-030-010-100	R1	10	3,6	50	6	<input checked="" type="checkbox"/>		
2CREG-030-010-120		12	3,6	50	6	<input checked="" type="checkbox"/>		
2CREG-030-010-160		16	3,6	55	6	<input checked="" type="checkbox"/>		
2CREG-030-010-200		20	3,6	60	6	<input checked="" type="checkbox"/>		
2CREG-030-010-250		25	3,6	65	6	<input checked="" type="checkbox"/>		
2CREG-030-010-300		30	3,6	70	6	<input checked="" type="checkbox"/>		
2CREG-030-010-350		35	3,6	75	6	<input checked="" type="checkbox"/>		
2CREG-030-010-400		40	3,6	80	6	<input checked="" type="checkbox"/>		
2CREG-040-001-050	4	R0,1	12	4,8	50	4	<input checked="" type="checkbox"/>	
2CREG-040-001-070			20	4,8	70	4	<input checked="" type="checkbox"/>	
2CREG-040-001-120			12	4,8	50	6	<input checked="" type="checkbox"/>	
2CREG-040-001-160			16	4,8	55	6	<input checked="" type="checkbox"/>	
2CREG-040-001-200			20	4,8	60	6	<input checked="" type="checkbox"/>	
2CREG-040-001-250			25	4,8	65	6	<input checked="" type="checkbox"/>	
2CREG-040-001-300		30	4,8	70	6	<input checked="" type="checkbox"/>		
2CREG-040-001-350		35	4,8	75	6	<input checked="" type="checkbox"/>		
2CREG-040-001-400		40	4,8	80	6	<input checked="" type="checkbox"/>		
2CREG-040-002-050		5	R0,2	12	4,8	50	4	<input checked="" type="checkbox"/>
2CREG-040-002-070				20	4,8	70	4	<input checked="" type="checkbox"/>
2CREG-040-002-120				12	4,8	50	6	<input checked="" type="checkbox"/>
2CREG-040-002-160	16			4,8	55	6	<input checked="" type="checkbox"/>	
2CREG-040-002-200	20			4,8	60	6	<input checked="" type="checkbox"/>	
2CREG-040-002-250	25			4,8	65	6	<input checked="" type="checkbox"/>	
2CREG-040-002-300	30		4,8	70	6	<input checked="" type="checkbox"/>		
2CREG-040-002-400	40		4,8	80	6	<input checked="" type="checkbox"/>		
2CREG-040-002-500	50		4,8	100	6	<input checked="" type="checkbox"/>		
2CREG-050-002-150	5		R0,5	15	6	55	6	<input checked="" type="checkbox"/>
2CREG-050-002-250				25	6	70	6	<input checked="" type="checkbox"/>
2CREG-050-002-300				30	6	70	6	<input checked="" type="checkbox"/>
2CREG-050-002-400		40		6	80	6	<input checked="" type="checkbox"/>	
2CREG-050-002-500		50		6	100	6	<input checked="" type="checkbox"/>	

Objednací číslo	D (mm)	R (mm)	L2 (mm)	L1 (mm)	L (mm)	d h5 (mm)	Standardní položka	
2CREG-040-001-450	4	R0,1	45	4,8	90	6	<input checked="" type="checkbox"/>	
2CREG-040-001-500			50	4,8	100	6	<input checked="" type="checkbox"/>	
2CREG-040-002-050			R0,2	12	4,8	50	4	<input checked="" type="checkbox"/>
2CREG-040-002-070				20	4,8	70	4	<input checked="" type="checkbox"/>
2CREG-040-002-120		12		4,8	50	6	<input checked="" type="checkbox"/>	
2CREG-040-002-160		16		4,8	55	6	<input checked="" type="checkbox"/>	
2CREG-040-002-200		20		4,8	60	6	<input checked="" type="checkbox"/>	
2CREG-040-002-250		25		4,8	65	6	<input checked="" type="checkbox"/>	
2CREG-040-002-300		30		4,8	70	6	<input checked="" type="checkbox"/>	
2CREG-040-002-350		35		4,8	75	6	<input checked="" type="checkbox"/>	
2CREG-040-002-400		40	4,8	80	6	<input checked="" type="checkbox"/>		
2CREG-040-002-450		45	4,8	90	6	<input checked="" type="checkbox"/>		
2CREG-040-002-500		50	4,8	100	6	<input checked="" type="checkbox"/>		
2CREG-040-003-050		R0,3	12	4,8	50	4	<input checked="" type="checkbox"/>	
2CREG-040-003-070			20	4,8	70	4	<input checked="" type="checkbox"/>	
2CREG-040-003-120			12	4,8	50	6	<input checked="" type="checkbox"/>	
2CREG-040-003-160			16	4,8	55	6	<input checked="" type="checkbox"/>	
2CREG-040-003-200			20	4,8	60	6	<input checked="" type="checkbox"/>	
2CREG-040-003-250			25	4,8	65	6	<input checked="" type="checkbox"/>	
2CREG-040-003-300			30	4,8	70	6	<input checked="" type="checkbox"/>	
2CREG-040-003-350			35	4,8	75	6	<input checked="" type="checkbox"/>	
2CREG-040-003-400		40	4,8	80	6	<input checked="" type="checkbox"/>		
2CREG-040-003-450		45	4,8	90	6	<input checked="" type="checkbox"/>		
2CREG-040-003-500		50	4,8	100	6	<input checked="" type="checkbox"/>		
2CREG-040-005-050	R0,5	12	4,8	50	4	<input checked="" type="checkbox"/>		
2CREG-040-005-070		20	4,8	70	4	<input checked="" type="checkbox"/>		
2CREG-040-005-120		12	4,8	50	6	<input checked="" type="checkbox"/>		
2CREG-040-005-160		16	4,8	55	6	<input checked="" type="checkbox"/>		
2CREG-040-005-200		20	4,8	60	6	<input checked="" type="checkbox"/>		
2CREG-040-005-250		25	4,8	65	6	<input checked="" type="checkbox"/>		
2CREG-040-005-300		30	4,8	70	6	<input checked="" type="checkbox"/>		
2CREG-040-005-350		35	4,8	75	6	<input checked="" type="checkbox"/>		
2CREG-040-005-400	40	4,8	80	6	<input checked="" type="checkbox"/>			
2CREG-040-005-500	50	4,8	100	6	<input checked="" type="checkbox"/>			
2CREG-040-010-050	5	R1	12	4,8	50	4	<input checked="" type="checkbox"/>	
2CREG-040-010-070			20	4,8	70	4	<input checked="" type="checkbox"/>	
2CREG-040-010-120			12	4,8	50	6	<input checked="" type="checkbox"/>	
2CREG-040-010-160			16	4,8	55	6	<input checked="" type="checkbox"/>	
2CREG-040-010-200			20	4,8	60	6	<input checked="" type="checkbox"/>	
2CREG-040-010-250			25	4,8	65	6	<input checked="" type="checkbox"/>	
2CREG-040-010-300		30	4,8	70	6	<input checked="" type="checkbox"/>		
2CREG-040-010-350		35	4,8	75	6	<input checked="" type="checkbox"/>		
2CREG-040-010-400		40	4,8	80	6	<input checked="" type="checkbox"/>		
2CREG-040-010-450		45	4,8	90	6	<input checked="" type="checkbox"/>		
2CREG-040-010-500		50	4,8	100	6	<input checked="" type="checkbox"/>		
2CREG-050-005-150		5	R0,5	15	6	55	6	<input checked="" type="checkbox"/>
2CREG-050-005-250	25			6	70	6	<input checked="" type="checkbox"/>	
2CREG-050-005-300	30			6	70	6	<input checked="" type="checkbox"/>	
2CREG-050-005-400	40			6	80	6	<input checked="" type="checkbox"/>	
2CREG-050-005-500	50			6	100	6	<input checked="" type="checkbox"/>	

2CREG

2-břité TOROIDNÍ frézy pro žebrování pro široký sortiment ocelí do HRC 52

Objednací číslo	D (mm)	R (mm)	L2 (mm)	L1 (mm)	L (mm)	d h5 (mm)	Standardní položka	
2CREG-050-005-250	5	R0,5	25	6	70	6	<input checked="" type="checkbox"/>	
2CREG-050-005-300			30	6	70	6	<input checked="" type="checkbox"/>	
2CREG-050-005-400			40	6	80	6	<input checked="" type="checkbox"/>	
2CREG-050-005-500			50	6	100	6	<input checked="" type="checkbox"/>	
2CREG-050-010-150		R1	15	6	55	6	<input checked="" type="checkbox"/>	
2CREG-050-010-250			25	6	70	6	<input checked="" type="checkbox"/>	
2CREG-050-010-300			30	6	70	6	<input checked="" type="checkbox"/>	
2CREG-050-010-400			40	6	80	6	<input checked="" type="checkbox"/>	
2CREG-050-010-500			50	6	100	6	<input checked="" type="checkbox"/>	
2CREG-060-001-200			6	R0,1	20	7	60	6
2CREG-060-001-400	40	7			90	6	<input checked="" type="checkbox"/>	
2CREG-060-002-200	R0,2	20		7	60	6	<input checked="" type="checkbox"/>	
2CREG-060-002-400		40		7	90	6	<input checked="" type="checkbox"/>	
2CREG-060-003-200	R0,3	20		7	60	6	<input checked="" type="checkbox"/>	
2CREG-060-003-400		40		7	90	6	<input checked="" type="checkbox"/>	
2CREG-060-005-200	R0,5	20		7	60	6	<input checked="" type="checkbox"/>	
2CREG-060-005-400		40		7	90	6	<input checked="" type="checkbox"/>	
2CREG-060-010-200	R1	20		7	60	6	<input checked="" type="checkbox"/>	
2CREG-060-010-400		40		7	90	6	<input checked="" type="checkbox"/>	
2CREG-060-015-200	R1,5	20		7	60	6	<input checked="" type="checkbox"/>	
2CREG-060-015-400		40		7	90	6	<input checked="" type="checkbox"/>	
2CREG-080-002-220	8	R0,2		22	9	65	8	<input checked="" type="checkbox"/>
2CREG-080-002-400				40	9	100	8	<input checked="" type="checkbox"/>
2CREG-080-003-220		R0,3		22	9	65	8	<input checked="" type="checkbox"/>
2CREG-080-003-400				40	9	100	8	<input checked="" type="checkbox"/>
2CREG-080-005-220		R0,5	22	9	65	8	<input checked="" type="checkbox"/>	
2CREG-080-005-400			40	9	100	8	<input checked="" type="checkbox"/>	
2CREG-080-010-220		R1	22	9	65	8	<input checked="" type="checkbox"/>	
2CREG-080-010-400			40	9	100	8	<input checked="" type="checkbox"/>	
2CREG-080-015-220		R1,5	22	9	65	8	<input checked="" type="checkbox"/>	
2CREG-080-015-400			40	9	100	8	<input checked="" type="checkbox"/>	
2CREG-100-002-240		10	R0,2	24	11	70	10	<input checked="" type="checkbox"/>
2CREG-100-002-450				45	11	100	10	<input checked="" type="checkbox"/>
2CREG-100-003-240	R0,3		24	11	70	10	<input checked="" type="checkbox"/>	
2CREG-100-003-450			45	11	100	10	<input checked="" type="checkbox"/>	
2CREG-100-005-240	R0,5		24	11	70	10	<input checked="" type="checkbox"/>	
2CREG-100-005-450			45	11	100	10	<input checked="" type="checkbox"/>	
2CREG-100-010-240	R1		24	11	70	10	<input checked="" type="checkbox"/>	
2CREG-100-010-450			45	11	100	10	<input checked="" type="checkbox"/>	
2CREG-100-015-240	R1,5		24	11	70	10	<input checked="" type="checkbox"/>	
2CREG-100-015-450			45	11	100	10	<input checked="" type="checkbox"/>	
2CREG-100-020-240	R2		24	11	70	10	<input checked="" type="checkbox"/>	
2CREG-100-020-450			45	11	100	10	<input checked="" type="checkbox"/>	
2CREG-120-002-260	12		R0,2	26	13	80	12	<input checked="" type="checkbox"/>
2CREG-120-002-500				50	13	110	12	<input checked="" type="checkbox"/>
2CREG-120-003-260		R0,3	26	13	80	12	<input checked="" type="checkbox"/>	
2CREG-120-003-500			50	13	110	12	<input checked="" type="checkbox"/>	
2CREG-120-005-260		R0,5	26	13	80	12	<input checked="" type="checkbox"/>	
2CREG-120-005-500			50	13	110	12	<input checked="" type="checkbox"/>	
2CREG-120-010-260		R1	26	13	80	12	<input checked="" type="checkbox"/>	
2CREG-120-010-500			50	13	110	12	<input checked="" type="checkbox"/>	
2CREG-120-015-260		R1,5	26	13	80	12	<input checked="" type="checkbox"/>	

Objednací číslo	D (mm)	R (mm)	L2 (mm)	L1 (mm)	L (mm)	d h5 (mm)	Standardní položka
2CREG-120-015-500	12	R1,5	50	13	110	12	<input checked="" type="checkbox"/>
2CREG-120-020-260		R2	26	13	80	12	<input checked="" type="checkbox"/>
2CREG-120-020-500			50	13	110	12	<input checked="" type="checkbox"/>
2CREG-120-030-260		R3	26	13	80	12	<input checked="" type="checkbox"/>
2CREG-120-030-500			50	13	110	12	<input checked="" type="checkbox"/>
2CREG-160-005-110		16	R0,5	35	20	110	16
2CREG-160-005-160	35			20	160	16	<input checked="" type="checkbox"/>
2CREG-160-010-110	R1		35	20	110	16	<input checked="" type="checkbox"/>
2CREG-160-010-160			35	20	160	16	<input checked="" type="checkbox"/>

4CREG 4-břité TOROIDNÍ frézy pro žebrování pro široký sortiment ocelí do HRC 52

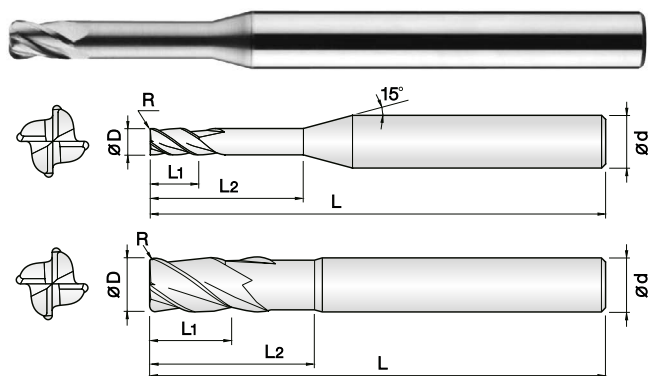

- Určeno pro široký sortiment různých typů ocelí do HRC 92
- Optimální pro různé typy ocelí díky AlCrN povlaku
- Velmi přesné tolerance rezných hran
- Široký sortiment vyložení a rádiusů pro optimální výběr nástroje
- Minimalizace vyštipování díky tvrdokovu s vysokou houževnatostí

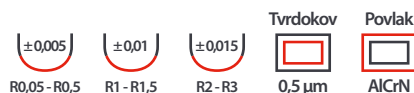

Objednací číslo	D (mm)	R (mm)	L2 (mm)	L1 (mm)	L (mm)	d h5 (mm)	Standardní položka	
4CREG-010-0005-040	1	R0,05	4	1,2	45	4	☑	
4CREG-010-0005-060			6	1,2	45	4	☑	
4CREG-010-0005-080			8	1,2	45	4	☑	
4CREG-010-0005-100			10	1,2	50	4	☑	
4CREG-010-0005-120			12	1,2	50	4	☑	
4CREG-010-0005-160			16	1,2	50	4	☑	
4CREG-010-0005-200			20	1,2	50	4	☑	
4CREG-010-001-040			R0,1	4	1,2	45	4	☑
4CREG-010-001-060		6		1,2	45	4	☑	
4CREG-010-001-080		8		1,2	45	4	☑	
4CREG-010-001-100		10		1,2	50	4	☑	
4CREG-010-001-120		12		1,2	50	4	☑	
4CREG-010-001-160		16		1,2	50	4	☑	
4CREG-010-001-200		20		1,2	50	4	☑	
4CREG-010-002-040		R0,2		4	1,2	45	4	☑
4CREG-010-002-060			6	1,2	45	4	☑	
4CREG-010-002-080			8	1,2	45	4	☑	
4CREG-010-002-100			10	1,2	50	4	☑	
4CREG-010-002-120			12	1,2	50	4	☑	
4CREG-010-002-160			16	1,2	50	4	☑	
4CREG-010-002-200			20	1,2	50	4	☑	
4CREG-010-003-040			R0,3	4	1,2	45	4	☑
4CREG-010-003-060		6		1,2	45	4	☑	
4CREG-010-003-080		8		1,2	45	4	☑	
4CREG-010-003-100		10		1,2	50	4	☑	
4CREG-010-003-120		12		1,2	50	4	☑	
4CREG-010-003-160		16		1,2	50	4	☑	
4CREG-010-003-200		20		1,2	50	4	☑	
4CREG-012-001-040		1,2		R0,1	4	1,4	45	4
4CREG-012-001-060			6		1,4	45	4	☑
4CREG-012-001-080			8		1,4	45	4	☑
4CREG-012-001-100			10		1,4	50	4	☑
4CREG-012-001-120	12		1,4		50	4	☑	
4CREG-012-001-160	16		1,4		50	4	☑	
4CREG-012-001-200	20		1,4		50	4	☑	
4CREG-012-002-040	R0,2		4		1,4	45	4	☑
4CREG-012-002-060			6	1,4	45	4	☑	
4CREG-012-002-080			8	1,4	45	4	☑	

Objednací číslo	D (mm)	R (mm)	L2 (mm)	L1 (mm)	L (mm)	d h5 (mm)	Standardní položka	
4CREG-012-002-100	1,2	R0,2	10	1,4	50	4	☑	
4CREG-012-002-120			12	1,4	50	4	☑	
4CREG-012-002-160			16	1,4	50	4	☑	
4CREG-012-002-200			20	1,4	50	4	☑	
4CREG-012-003-040		R0,3	4	1,4	45	4	☑	
4CREG-012-003-060			6	1,4	45	4	☑	
4CREG-012-003-080			8	1,4	45	4	☑	
4CREG-012-003-100			10	1,4	50	4	☑	
4CREG-012-003-120			12	1,4	50	4	☑	
4CREG-012-003-160			16	1,4	50	4	☑	
4CREG-012-003-200			20	1,4	50	4	☑	
4CREG-015-001-060			1,5	R0,1	6	1,8	45	4
4CREG-015-001-080		8			1,8	45	4	☑
4CREG-015-001-100		10			1,8	50	4	☑
4CREG-015-001-120		12			1,8	50	4	☑
4CREG-015-001-160		16			1,8	50	4	☑
4CREG-015-001-200	20	1,8			50	4	☑	
4CREG-015-001-220	22	1,8			60	4	☑	
4CREG-015-001-250	25	1,8			60	4	☑	
4CREG-015-002-060	R0,2	6		1,8	45	4	☑	
4CREG-015-002-080		8		1,8	45	4	☑	
4CREG-015-002-100		10		1,8	50	4	☑	
4CREG-015-002-120		12		1,8	50	4	☑	
4CREG-015-002-160		16		1,8	50	4	☑	
4CREG-015-002-200		20		1,8	50	4	☑	
4CREG-015-002-220		22		1,8	60	4	☑	
4CREG-015-002-250		25		1,8	60	4	☑	
4CREG-015-003-060	R0,3	6	1,8	45	4	☑		
4CREG-015-003-080		8	1,8	45	4	☑		
4CREG-015-003-100		10	1,8	50	4	☑		
4CREG-015-003-120		12	1,8	50	4	☑		
4CREG-015-003-160		16	1,8	50	4	☑		
4CREG-015-003-200		20	1,8	50	4	☑		
4CREG-015-003-220		22	1,8	60	4	☑		
4CREG-015-003-250		25	1,8	60	4	☑		
4CREG-015-005-060	R0,5	6	1,8	45	4	☑		
4CREG-015-005-080		8	1,8	45	4	☑		
4CREG-015-005-100		10	1,8	50	4	☑		

4CREG

4-břité TOROIDNÍ frézy pro žebrování pro široký sortiment ocelí do HRC 52

Objednací číslo	D (mm)	R (mm)	L2 (mm)	L1 (mm)	L (mm)	d h5 (mm)	Standardní položka	Objednací číslo	D (mm)	R (mm)	L2 (mm)	L1 (mm)	L (mm)	d h5 (mm)	Standardní položka		
4CREG-015-005-120	1,5	R0,5	12	1,8	50	4	☑	4CREG-025-003-160	2,5	R0,3	16	3	50	4	☑		
4CREG-015-005-160			16	1,8	50	4	☑	4CREG-025-003-200			20	3	50	4	☑		
4CREG-015-005-200			20	1,8	50	4	☑	4CREG-025-003-250			25	3	60	4	☑		
4CREG-015-005-220			22	1,8	60	4	☑	4CREG-025-003-300			30	3	70	4	☑		
4CREG-015-005-250			25	1,8	60	4	☑	4CREG-025-005-100			10	3	50	4	☑		
4CREG-020-001-060	2	R0,1	6	2,4	45	4	☑	4CREG-025-005-160	R0,5	16	3	50	4	☑			
4CREG-020-001-080			8	2,4	45	4	☑	4CREG-025-005-200		20	3	50	4	☑			
4CREG-020-001-100			10	2,4	50	4	☑	4CREG-025-005-250		25	3	60	4	☑			
4CREG-020-001-120			12	2,4	50	4	☑	4CREG-025-005-300		30	3	70	4	☑			
4CREG-020-001-160			16	2,4	50	4	☑	4CREG-030-001-100		10	3,6	50	6	☑			
4CREG-020-001-200			20	2,4	50	4	☑	4CREG-030-001-160		16	3,6	55	6	☑			
4CREG-020-001-250			25	2,4	60	4	☑	4CREG-030-001-200		20	3,6	60	6	☑			
4CREG-020-001-300			30	2,4	70	4	☑	4CREG-030-001-250		25	3,6	65	6	☑			
4CREG-020-001-350			35	2,4	70	4	☑	4CREG-030-001-300		30	3,6	70	6	☑			
4CREG-020-002-060			R0,2	R0,1	6	2,4	45	4		☑	4CREG-030-001-350	35	3,6	75	6	☑	
4CREG-020-002-080					8	2,4	45	4		☑	4CREG-030-001-400	40	3,6	80	6	☑	
4CREG-020-002-100					10	2,4	50	4		☑	4CREG-030-001-500	50	3,6	100	6	☑	
4CREG-020-002-120					12	2,4	50	4		☑	4CREG-030-002-100	10	3,6	50	6	☑	
4CREG-020-002-160					16	2,4	50	4		☑	4CREG-030-002-160	16	3,6	55	6	☑	
4CREG-020-002-200					20	2,4	50	4		☑	4CREG-030-002-200	20	3,6	60	6	☑	
4CREG-020-002-250		25			2,4	60	4	☑	4CREG-030-002-250	25	3,6	65	6	☑			
4CREG-020-002-300		30			2,4	70	4	☑	4CREG-030-002-300	30	3,6	70	6	☑			
4CREG-020-002-350		35			2,4	70	4	☑	4CREG-030-002-350	35	3,6	75	6	☑			
4CREG-020-003-060		R0,3			R0,2	6	2,4	45	4	☑	4CREG-030-002-400	40	3,6	80	6	☑	
4CREG-020-003-080						8	2,4	45	4	☑	4CREG-030-002-500	50	3,6	100	6	☑	
4CREG-020-003-100						10	2,4	50	4	☑	4CREG-030-003-100	10	3,6	50	6	☑	
4CREG-020-003-120						12	2,4	50	4	☑	4CREG-030-003-160	16	3,6	55	6	☑	
4CREG-020-003-160						16	2,4	50	4	☑	4CREG-030-003-200	20	3,6	60	6	☑	
4CREG-020-003-200						20	2,4	50	4	☑	4CREG-030-003-250	25	3,6	65	6	☑	
4CREG-020-003-250				25		2,4	60	4	☑	4CREG-030-003-300	30	3,6	70	6	☑		
4CREG-020-003-300				30		2,4	70	4	☑	4CREG-030-003-350	35	3,6	75	6	☑		
4CREG-020-003-350				35		2,4	70	4	☑	4CREG-030-003-400	40	3,6	80	6	☑		
4CREG-020-005-060				R0,5		R0,3	6	2,4	45	4	☑	4CREG-030-003-500	50	3,6	100	6	☑
4CREG-020-005-080							8	2,4	45	4	☑	4CREG-030-005-100	10	3,6	50	6	☑
4CREG-020-005-100							10	2,4	50	4	☑	4CREG-030-005-160	16	3,6	55	6	☑
4CREG-020-005-120							12	2,4	50	4	☑	4CREG-030-005-200	20	3,6	60	6	☑
4CREG-020-005-160							16	2,4	50	4	☑	4CREG-030-005-250	25	3,6	65	6	☑
4CREG-020-005-200							20	2,4	50	4	☑	4CREG-030-005-300	30	3,6	70	6	☑
4CREG-020-005-250		25			2,4		60	4	☑	4CREG-030-005-350	35	3,6	75	6	☑		
4CREG-020-005-300		30			2,4		70	4	☑	4CREG-030-005-400	40	3,6	80	6	☑		
4CREG-020-005-350	35	2,4			70		4	☑	4CREG-030-005-500	50	3,6	100	6	☑			
4CREG-025-001-100	2,5	R0,5			6		2,4	45	4	☑	4CREG-030-010-100	10	3,6	50	6	☑	
4CREG-025-001-080					8		2,4	45	4	☑	4CREG-030-010-160	16	3,6	55	6	☑	
4CREG-025-001-100					10		2,4	50	4	☑	4CREG-030-010-200	20	3,6	60	6	☑	
4CREG-025-001-120			12		2,4		50	4	☑	4CREG-030-010-250	25	3,6	65	6	☑		
4CREG-025-001-160			16		2,4		50	4	☑	4CREG-030-010-300	30	3,6	70	6	☑		
4CREG-025-001-200		20	2,4		50		4	☑	4CREG-030-010-350	35	3,6	75	6	☑			
4CREG-025-001-250		R0,1	R0,5	25	2,4	60	4	☑	4CREG-030-010-400	40	3,6	80	6	☑			
4CREG-025-001-300				30	2,4	70	4	☑	4CREG-030-010-500	50	3,6	100	6	☑			
4CREG-025-002-100				10	3	50	4	☑	4CREG-040-001-050	12	4,8	50	4	☑			
4CREG-025-002-160				16	3	50	4	☑	4CREG-040-001-070	20	4,8	70	4	☑			
4CREG-025-002-200				20	3	50	4	☑	4CREG-040-001-120	12	4,8	50	6	☑			
4CREG-025-002-250				25	3	60	4	☑									
4CREG-025-002-300				30	3	70	4	☑									
4CREG-025-003-100				10	3	50	4	☑									

4CREG

4-břité TOROIDNÍ frézy pro žebrování pro široký sortiment ocelí do HRC 52

Objednací číslo	D (mm)	R (mm)	L2 (mm)	L1 (mm)	L (mm)	d h5 (mm)	Standardní položka	Objednací číslo	D (mm)	R (mm)	L2 (mm)	L1 (mm)	L (mm)	d h5 (mm)	Standardní položka			
4CREG-040-001-160	4	R0,1	16	4,8	55	6	☑	4CREG-050-001-150	5	R0,1	15	6	55	6	☑			
4CREG-040-001-200			20	4,8	60	6	☑	4CREG-050-001-300			30	6	70	6	☑			
4CREG-040-001-250			25	4,8	65	6	☑	4CREG-050-001-400			40	6	80	6	☑			
4CREG-040-001-300			30	4,8	70	6	☑	4CREG-050-001-500			50	6	100	6	☑			
4CREG-040-001-350			35	4,8	75	6	☑	4CREG-050-002-150			R0,2	15	6	55	6	☑		
4CREG-040-001-400			40	4,8	80	6	☑	4CREG-050-002-300				30	6	70	6	☑		
4CREG-040-001-450			45	4,8	90	6	☑	4CREG-050-002-400				40	6	80	6	☑		
4CREG-040-001-500			50	4,8	100	6	☑	4CREG-050-002-500			50	6	100	6	☑			
4CREG-040-002-050		R0,2	R0,3	12	4,8	50	4	☑		4CREG-050-003-150	R0,3	15	6	55	6	☑		
4CREG-040-002-070				20	4,8	70	4	☑		4CREG-050-003-300		30	6	70	6	☑		
4CREG-040-002-120				12	4,8	50	6	☑		4CREG-050-003-400		40	6	80	6	☑		
4CREG-040-002-160				16	4,8	55	6	☑		4CREG-050-003-500		50	6	100	6	☑		
4CREG-040-002-200			20	4,8	60	6	☑	4CREG-050-005-150		R0,5	15	6	55	6	☑			
4CREG-040-002-250			25	4,8	65	6	☑	4CREG-050-005-300			30	6	70	6	☑			
4CREG-040-002-300			30	4,8	70	6	☑	4CREG-050-005-400			40	6	80	6	☑			
4CREG-040-002-350			35	4,8	75	6	☑	4CREG-050-005-500		50	6	100	6	☑				
4CREG-040-002-400			40	4,8	80	6	☑	4CREG-050-010-150		R1	15	6	55	6	☑			
4CREG-040-002-450			45	4,8	90	6	☑	4CREG-050-010-300			30	6	70	6	☑			
4CREG-040-002-500			50	4,8	100	6	☑	4CREG-050-010-400			40	6	80	6	☑			
4CREG-040-003-050			R0,3	R0,5	12	4,8	50	4		☑	4CREG-050-010-500	R0,5	50	6	100	6	☑	
4CREG-040-003-070					20	4,8	70	4		☑	4CREG-060-001-200		R0,1	20	7	60	6	☑
4CREG-040-003-120					12	4,8	50	6		☑	4CREG-060-001-400			40	7	80	6	☑
4CREG-040-003-160					16	4,8	55	6		☑	4CREG-060-001-500			50	7	100	6	☑
4CREG-040-003-200				20	4,8	60	6	☑		4CREG-060-002-200	R0,2	20	7	60	6	☑		
4CREG-040-003-250		25		4,8	65	6	☑	4CREG-060-002-400		40		7	80	6	☑			
4CREG-040-003-300		30		4,8	70	6	☑	4CREG-060-002-500		50		7	100	6	☑			
4CREG-040-003-350		35		4,8	75	6	☑	4CREG-060-003-200		R0,3	20	7	60	6	☑			
4CREG-040-003-400		40		4,8	80	6	☑	4CREG-060-003-400			40	7	80	6	☑			
4CREG-040-003-450		45		4,8	90	6	☑	4CREG-060-003-500			50	7	100	6	☑			
4CREG-040-003-500		50		4,8	100	6	☑	4CREG-060-005-200		R0,5	20	7	60	6	☑			
4CREG-040-005-050		12		4,8	50	4	☑	4CREG-060-005-400			40	7	80	6	☑			
4CREG-040-005-070		20		4,8	70	4	☑	4CREG-060-005-500			50	7	100	6	☑			
4CREG-040-005-120		12		4,8	50	6	☑	4CREG-060-010-200		R1	20	7	60	6	☑			
4CREG-040-005-160		16		4,8	55	6	☑	4CREG-060-010-400			40	7	80	6	☑			
4CREG-040-005-200		20		4,8	60	6	☑	4CREG-060-010-500			50	7	100	6	☑			
4CREG-040-005-250		R0,5		R1,5	25	4,8	65	6		☑	4CREG-060-015-200	R1,5	20	7	60	6	☑	
4CREG-040-005-300					30	4,8	70	6		☑	4CREG-060-015-400		40	7	80	6	☑	
4CREG-040-005-350					35	4,8	75	6		☑	4CREG-060-015-500		50	7	100	6	☑	
4CREG-040-005-400					40	4,8	80	6		☑	4CREG-080-002-220		R0,2	22	9	65	8	☑
4CREG-040-005-450			45	4,8	90	6	☑	4CREG-080-003-220		22	9	65		8	☑			
4CREG-040-005-500	50		4,8	100	6	☑	4CREG-080-005-220	R0,5	22	9	65	8		☑				
4CREG-040-010-050	12		4,8	50	4	☑	4CREG-080-005-400		40	9	100	8	☑					
4CREG-040-010-070	20		4,8	70	4	☑	4CREG-080-010-220	R1	22	9	65	8	☑					
4CREG-040-010-120	12	4,8	50	6	☑	4CREG-080-010-400	40		9	100	8	☑						
4CREG-040-010-160	16	4,8	55	6	☑	4CREG-080-015-220	R1,5	22	9	65	8	☑						
4CREG-040-010-200	20	4,8	60	6	☑	4CREG-080-015400		40	9	100	8	☑						
4CREG-040-010-250	R1	R2	22	9	65	8	☑	4CREG-080-020-220	R0,2	24	11	70	10	☑				
4CREG-040-010-300		30	4,8	70	6	☑	4CREG-100-002-240	24		11	70	10	☑					
4CREG-040-010-350		35	4,8	75	6	☑	4CREG-100-003-240	24		11	70	10	☑					
4CREG-040-010-400		40	4,8	80	6	☑	4CREG-100-005-240	R0,5	24	11	70	10	☑					
4CREG-040-010-450		45	4,8	90	6	☑	4CREG-100-005-400		40	11	100	10	☑					
4CREG-040-010-500		50	4,8	100	6	☑	4CREG-100-010-240		R1	24	11	70	10	☑				

4CREG

4-břité TOROIDNÍ frézy pro žebrování pro široký sortiment ocelí do HRC 52

Objednací číslo	D (mm)	R (mm)	L2 (mm)	L1 (mm)	L (mm)	d h5 (mm)	Standardní položka
4CREG-100-010-400	10	R1	40	11	100	10	<input checked="" type="checkbox"/>
4CREG-100-015-240		R1,5	24	11	70	10	<input checked="" type="checkbox"/>
4CREG-100-015-400			40	11	100	10	<input checked="" type="checkbox"/>
4CREG-100-020-240		R2	24	11	70	10	<input checked="" type="checkbox"/>
4CREG-100-025-240		R2,5	24	11	70	10	<input checked="" type="checkbox"/>
4CREG-120-003-260	12	R0,3	26	13	80	12	<input checked="" type="checkbox"/>
4CREG-120-005-260		R0,5	26	13	80	12	<input checked="" type="checkbox"/>
4CREG-120-005-400			40	13	110	12	<input checked="" type="checkbox"/>
4CREG-120-010-260		R1	26	13	80	12	<input checked="" type="checkbox"/>
4CREG-120-010-400			40	13	110	12	<input checked="" type="checkbox"/>
4CREG-120-015-260		R1,5	26	13	80	12	<input checked="" type="checkbox"/>
4CREG-120-015-400			40	13	110	12	<input checked="" type="checkbox"/>
4CREG-120-020-260		R2	26	13	80	12	<input checked="" type="checkbox"/>
4CREG-120-030-260		R3	26	13	80	12	<input checked="" type="checkbox"/>

2HSBG 2-břité KULOVÉ frézy krátké pro široký sortiment ocelí do HRC 52

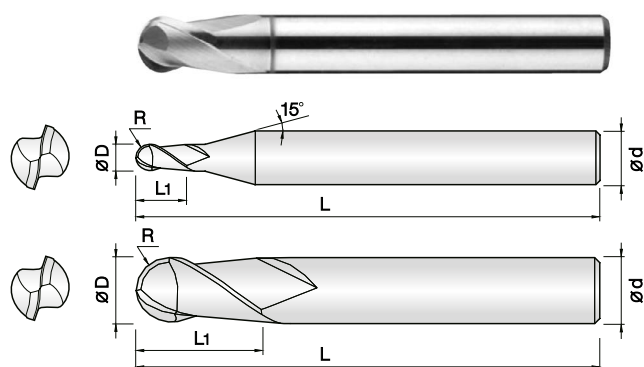

- ▶ Určeno pro široký sortiment různých typů ocelí do HRC 52
- ▶ Optimální pro různé typy ocelí díky AlCrN povlaku
- ▶ Velmi přesné tolerance řezných hran
- ▶ Vysoká tuhost
- ▶ Minimalizace vyštipování díky tvrdokovu s vysokou houževnatostí

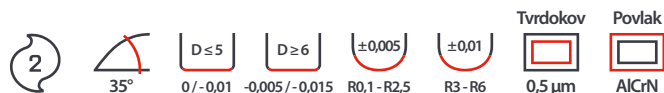

Objednací číslo	D (mm)	R (mm)	L1 (mm)	L (mm)	d h5 (mm)	Standardní položka
2HSBG-002-002-S04	0,2	0,1	0,2	40	4	☑
2HSBG-003-003-S04	0,3	0,15	0,3	40	4	☑
2HSBG-004-004-S04	0,4	0,2	0,4	40	4	☑
2HSBG-005-005-S04	0,5	0,25	0,5	40	4	☑
2HSBG-006-006-S04	0,6	0,3	0,6	40	4	☑
2HSBG-007-007-S04	0,7	0,35	0,7	40	4	☑
2HSBG-008-008-S04	0,8	0,4	0,8	40	4	☑
2HSBG-009-009-S04	0,9	0,45	0,9	40	4	☑
2HSBG-010-010-S04	1	0,5	1	40	4	☑
2HSBG-010-010-S06			1	40	6	☑
2HSBG-015-015-S04	1,5	0,75	1,5	40	4	☑
2HSBG-015-015-S06			1,5	40	6	☑
2HSBG-020-020-S04	2	1	2	45	4	☑
2HSBG-020-020-S06			2	45	6	☑
2HSBG-030-030-S04	3	1,5	3	45	4	☑
2HSBG-030-030-S06			3	45	6	☑
2HSBG-040-040-S04	4	2	4	45	4	☑
2HSBG-040-040-S06			4	45	6	☑
2HSBG-050-050-S06	5	2,5	5	50	6	☑
2HSBG-060-060-050	6	3	6	50	6	☑
2HSBG-060-060-060			6	60	6	☑
2HSBG-080-080-050	8	4	8	50	8	☑
2HSBG-080-080-060			8	60	8	☑
2HSBG-100-100-060	10	5	10	60	10	☑
2HSBG-100-100-070			10	70	10	☑
2HSBG-120-120-060	12	6	12	60	12	☑
2HSBG-120-120-070			12	70	12	☑

2HCBG 2-břité KULOVÉ frézy pro široký sortiment ocelí do HRC 52

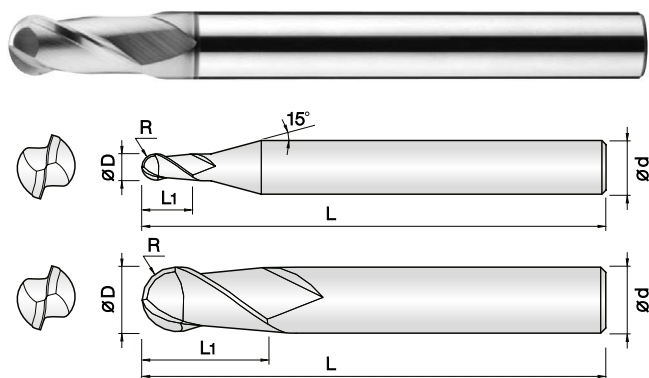

- Určeno pro široký sortiment různých typů ocelí do HRC 52
- Optimální pro různé typy ocelí díky AlCrN povlaku
- Velmi přesné tolerance řezných hran
- Minimalizace vyštipování díky tvrdokovu s vysokou houževnatostí

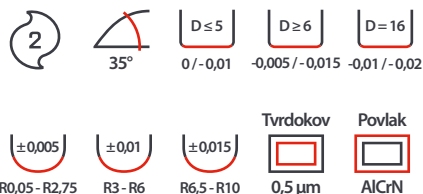

Objednací číslo	D (mm)	R (mm)	L1 (mm)	L (mm)	d h5 (mm)	Standardní položka
2HCBG-001-002-S04	0,1	R0,05	0,2	40	4	☑
2HCBG-0015-003-S04	0,15	R0,075	0,3	40	4	☑
2HCBG-002-004-S04	0,2	R0,1	0,4	40	4	☑
2HCBG-003-006-S04	0,3	R0,15	0,6	40	4	☑
2HCBG-004-008-S04	0,4	R0,2	0,8	40	4	☑
2HCBG-005-010-S04	0,5	R0,25	1	45	4	☑
2HCBG-006-012-S04	0,6	R0,3	1,2	45	4	☑
2HCBG-007-015-S04	0,7	R0,35	1,5	45	4	☑
2HCBG-008-020-S04	0,8	R0,4	2	45	4	☑
2HCBG-009-020-S04	0,9	R0,45	2	45	4	☑
2HCBG-010-025-S04	1	R0,5	2,5	50	4	☑
2HCBG-010-025-S06			2,5	50	6	☑
2HCBG-010-025-070			2,5	70	6	☑
2HCBG-010-025-100			2,5	100	6	☑
2HCBG-012-030-S04	1,2	R0,6	3	50	4	☑
2HCBG-015-040-S04	1,5	R0,75	4	50	4	☑
2HCBG-015-040-S06			4	50	6	☑
2HCBG-015-040-070			4	70	6	☑
2HCBG-015-040-100			4	100	6	☑
2HCBG-020-050-S04	2	R1	5	50	4	☑
2HCBG-020-050-S06			5	50	6	☑
2HCBG-020-050-075			5	75	6	☑
2HCBG-020-050-100			5	100	6	☑
2HCBG-025-060-S04	2,5	R1,25	6	50	4	☑
2HCBG-025-060-S06			6	60	6	☑
2HCBG-025-060-075			6	75	6	☑
2HCBG-025-060-100			6	100	6	☑
2HCBG-030-080-S03	3	R1,5	8	60	3	☑
2HCBG-030-080-S04			8	50	4	☑
2HCBG-030-080-S06			8	60	6	☑
2HCBG-030-080-080			8	80	6	☑
2HCBG-030-080-100			8	100	6	☑
2HCBG-035-080-S06			8	100	6	☑
2HCBG-040-080-060	4	R2	8	60	4	☑
2HCBG-040-080-080			8	80	4	☑
2HCBG-040-080-S06			8	70	6	☑
2HCBG-040-080-090			8	90	6	☑
2HCBG-040-080-120			8	120	6	☑

Objednací číslo	D (mm)	R (mm)	L1 (mm)	L (mm)	d h5 (mm)	Standardní položka
2HCBG-045-080-S06	4,5	R2,25	8	70	6	☑
2HCBG-050-080-S05	5	R2,5	8	80	5	☑
2HCBG-050-100-S06			10	75	6	☑
2HCBG-055-100-S06	5,5	R2,75	10	75	6	☑
2HCBG-060-100-060	6	R3	10	60	6	☑
2HCBG-060-120-080			12	80	6	☑
2HCBG-060-120-100			12	100	6	☑
2HCBG-060-120-120			12	120	6	☑
2HCBG-070-140-S08	7	R3,5	14	80	8	☑
2HCBG-080-120-060	8	R4	12	60	8	☑
2HCBG-080-140-090			14	90	8	☑
2HCBG-080-140-110			14	110	8	☑
2HCBG-080-140-150			14	150	8	☑
2HCBG-090-160-S10	9	R4,5	16	100	10	☑
2HCBG-100-150-070	10	R5	15	70	10	☑
2HCBG-100-180-100			18	100	10	☑
2HCBG-100-180-120			18	120	10	☑
2HCBG-100-180-150			18	150	10	☑
2HCBG-100-180-180			18	180	10	☑
2HCBG-110-200-S12	11	R5,5	20	110	12	☑
2HCBG-120-180-070	12	R6	18	70	12	☑
2HCBG-120-220-110			22	110	12	☑
2HCBG-120-220-130			22	130	12	☑
2HCBG-120-220-150			22	150	12	☑
2HCBG-120-220-200	22	200	12	☑		
2HCBG-130-240-S14	13	R6,5	24	110	14	☑
2HCBG-140-240-S14	14	R7	24	110	14	☑
2HCBG-160-300-130	16	R8	30	130	16	☑
2HCBG-160-300-160			30	160	16	☑
2HCBG-160-300-200			30	200	16	☑
2HCBG-200-380-160	20	R10	38	160	20	☑
2HCBG-200-380-200			38	200	20	☑

2HCEG 2-břité OSTRÉ frézy pro široký sortiment ocelí do HRC 52

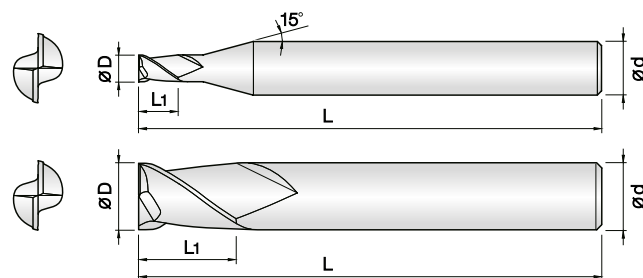

- ▶ Určeno pro široký sortiment různých typů ocelí do HRC 52
- ▶ Optimální pro různé typy ocelí díky AlCrN povlaku
- ▶ Velmi přesné tolerance řezných hran
- ▶ Minimalizace vyštipování díky tvrdokovu s vysokou houževnatostí

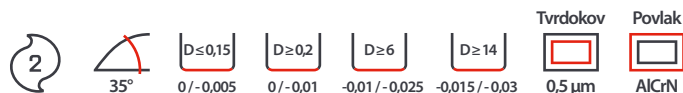

Objednací číslo	D (mm)	L1 (mm)	L (mm)	d h5 (mm)	Standardní položka
2HCEG-001-002-S04	0,1	0,2	38	4	☑
2HCEG-0015-003-S04	0,15	0,3	38	4	☑
2HCEG-002-004-S04	0,2	0,4	38	4	☑
2HCEG-0025-005-S04	0,25	0,5	38	4	☑
2HCEG-003-006-S04	0,3	0,6	38	4	☑
2HCEG-0035-007-S04	0,35	0,7	38	4	☑
2HCEG-004-008-S04	0,4	0,8	38	4	☑
2HCEG-0045-009-S04	0,45	0,9	38	4	☑
2HCEG-005-010-S04	0,5	1	38	4	☑
2HCEG-0055-011-S04	0,55	1,1	38	4	☑
2HCEG-006-012-S04	0,6	1,2	38	4	☑
2HCEG-0065-013-S04	0,65	1,3	38	4	☑
2HCEG-007-014-S04	0,7	1,4	38	4	☑
2HCEG-0075-015-S04	0,75	1,5	38	4	☑
2HCEG-008-016-S04	0,8	1,6	38	4	☑
2HCEG-0085-017-S04	0,85	1,7	38	4	☑
2HCEG-009-020-S04	0,9	2	38	4	☑
2HCEG-0095-020-S04	0,95	2	38	4	☑
2HCEG-010-010-S04	1	1	40	4	☑
2HCEG-010-025-S04		2,5	40	4	☑
2HCEG-010-025-S06		2,5	40	6	☑
2HCEG-010-025-060		2,5	60	6	☑
2HCEG-010-040-S06	1,1	4	50	6	☑
2HCEG-011-027-S04		2,7	40	4	☑
2HCEG-012-012-S04	1,2	1,2	40	4	☑
2HCEG-012-030-S04		3	40	4	☑
2HCEG-012-030-S06		3	40	6	☑
2HCEG-012-030-060		3	60	6	☑
2HCEG-012-060-S06	1,3	6	50	6	☑
2HCEG-013-032-S04		3,2	40	4	☑
2HCEG-014-035-S04	1,4	3,5	40	4	☑
2HCEG-015-015-S04	1,5	1,5	40	4	☑
2HCEG-015-040-S04		4	40	4	☑
2HCEG-015-040-S06		4	40	6	☑
2HCEG-015-040-060		4	60	6	☑
2HCEG-016-040-S04	1,6	4	40	4	☑
2HCEG-017-042-S04	1,7	4,2	40	4	☑
2HCEG-018-045-S04	1,8	4,5	40	4	☑

Objednací číslo	D (mm)	L1 (mm)	L (mm)	d h5 (mm)	Standardní položka
2HCEG-019-050-S04	1,9	5	40	4	☑
2HCEG-020-020-S04	2	2	40	4	☑
2HCEG-020-060-S04		6	40	4	☑
2HCEG-020-060-S06		6	40	6	☑
2HCEG-020-060-060		6	60	6	☑
2HCEG-021-060-S04	2,1	6	40	4	☑
2HCEG-022-060-S04	2,2	6	40	4	☑
2HCEG-023-060-S04	2,3	6	40	4	☑
2HCEG-024-080-S04	2,4	8	45	4	☑
2HCEG-025-080-S04	2,5	8	45	4	☑
2HCEG-025-080-S06		8	45	6	☑
2HCEG-025-080-070		8	70	6	☑
2HCEG-026-080-S04	2,6	8	45	4	☑
2HCEG-027-080-S04	2,7	8	45	4	☑
2HCEG-028-080-S04	2,8	8	45	4	☑
2HCEG-029-080-S04	2,9	8	45	4	☑
2HCEG-030-030-S04	3	3	40	4	☑
2HCEG-030-080-S04		8	45	4	☑
2HCEG-030-080-S06		8	45	6	☑
2HCEG-030-080-070	3,5	8	70	6	☑
2HCEG-035-100-S06		10	45	6	☑
2HCEG-040-040-S04	4	4	40	4	☑
2HCEG-040-100-S04		10	45	4	☑
2HCEG-040-110-S06		11	45	6	☑
2HCEG-040-110-070		11	70	6	☑
2HCEG-045-110-S06	4,5	11	45	6	☑
2HCEG-050-130-S06	5	13	50	6	☑
2HCEG-050-130-080		13	80	6	☑
2HCEG-055-130-S06	5,5	13	50	6	☑
2HCEG-060-060-S06	6	6	45	6	☑
2HCEG-060-130-S06		13	50	6	☑
2HCEG-060-130-080		13	80	6	☑
2HCEG-060-150-S06		15	60	6	☑
2HCEG-065-160-S08	6,5	16	60	8	☑
2HCEG-070-160-S08	7	16	60	8	☑
2HCEG-075-160-S08	7,5	16	60	8	☑
2HCEG-080-080-S08	8	8	50	8	☑
2HCEG-080-190-S08		19	60	8	☑

2HCEG 2-břité OSTRÉ frézy pro široký sortiment ocelí do HRC 52

Objednací číslo	D (mm)	L1 (mm)	L (mm)	d h5 (mm)	Standardní položka
2HCEG-080-200-S08	8	20	70	8	<input checked="" type="checkbox"/>
2HCEG-085-190-S10	8,5	19	70	10	<input checked="" type="checkbox"/>
2HCEG-090-190-S10	9	19	70	10	<input checked="" type="checkbox"/>
2HCEG-095-190-S10	9,5	19	70	10	<input checked="" type="checkbox"/>
2HCEG-100-100-S10	10	10	60	10	<input checked="" type="checkbox"/>
2HCEG-100-220-S10		22	70	10	<input checked="" type="checkbox"/>
2HCEG-100-250-S10		25	75	10	<input checked="" type="checkbox"/>
2HCEG-105-220-S12	10,5	22	75	12	<input checked="" type="checkbox"/>
2HCEG-110-220-S12	11	22	75	12	<input checked="" type="checkbox"/>
2HCEG-115-220-S12	11,5	22	75	12	<input checked="" type="checkbox"/>
2HCEG-120-120-S12	12	12	65	12	<input checked="" type="checkbox"/>
2HCEG-120-260-S12		26	75	12	<input checked="" type="checkbox"/>
2HCEG-120-300-S12		30	80	12	<input checked="" type="checkbox"/>
2HCEG-140-260-S14	14	26	80	14	<input checked="" type="checkbox"/>
2HCEG-140-260-S16		26	85	16	<input checked="" type="checkbox"/>
2HCEG-160-350-S16	16	35	100	16	<input checked="" type="checkbox"/>
2HCEG-160-400-S16		40	100	16	<input checked="" type="checkbox"/>
2HCEG-180-350-S18	18	35	100	18	<input checked="" type="checkbox"/>
2HCEG-200-400-S20	20	40	100	20	<input checked="" type="checkbox"/>
2HCEG-200-500-S20		50	110	20	<input checked="" type="checkbox"/>

2LEMG 2-břité OSTRÉ frézy dlouhé pro široký sortiment ocelí do HRC 52

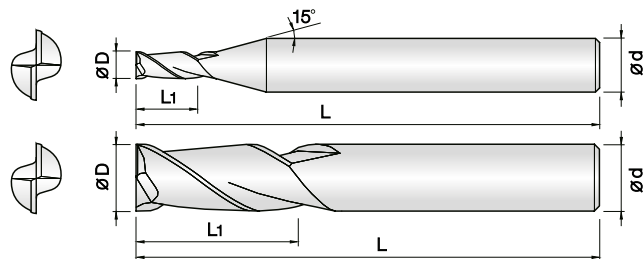

- Určeno pro široký sortiment různých typů ocelí do HRC 52
- Optimální pro různé typy ocelí díky AlCrN povlaku
- Široký sortiment délek pro optimální volbu nástroje
- Minimalizace vyštipování díky tvrdokovu s vysokou houževnatostí

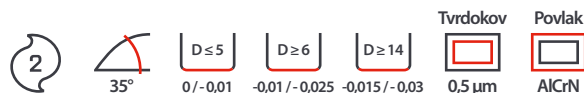

Objednací číslo	D (mm)	L1 (mm)	L (mm)	d h5 (mm)	Standardní položka
2LEMG-010-030-S06	1	3	60	6	☑
2LEMG-010-050-S06		5	60	6	☑
2LEMG-010-070-S06		7	60	6	☑
2LEMG-010-100-S06		10	60	6	☑
2LEMG-010-150-S06		15	60	6	☑
2LEMG-015-060-S06	1,5	6	60	6	☑
2LEMG-015-075-S06		7.5	60	6	☑
2LEMG-015-100-S06		10	60	6	☑
2LEMG-015-150-S06		15	60	6	☑
2LEMG-015-200-S06	2	20	60	6	☑
2LEMG-020-060-S06		6	60	6	☑
2LEMG-020-100-S06		10	60	6	☑
2LEMG-020-150-S06		15	60	6	☑
2LEMG-020-200-S06		20	60	6	☑
2LEMG-030-120-S06	3	12	70	6	☑
2LEMG-030-150-S06		15	70	6	☑
2LEMG-030-200-S06		20	70	6	☑
2LEMG-030-250-S06		25	70	6	☑
2LEMG-030-300-S06		30	70	6	☑
2LEMG-040-150-S06	4	15	70	6	☑
2LEMG-040-200-S06		20	70	6	☑
2LEMG-040-300-S06		30	75	6	☑
2LEMG-050-200-S06	5	20	70	6	☑
2LEMG-050-250-S06		25	75	6	☑
2LEMG-050-300-S06		30	80	6	☑
2LEMG-060-200-S06	6	20	75	6	☑
2LEMG-060-200-100		20	100	6	☑
2LEMG-060-250-S06		25	75	6	☑
2LEMG-060-300-S06		30	80	6	☑
2LEMG-080-250-S08	8	25	75	8	☑
2LEMG-080-250-100		25	100	8	☑
2LEMG-080-300-S08		30	80	8	☑
2LEMG-080-350-S08		35	80	8	☑
2LEMG-080-400-S08		40	90	8	☑
2LEMG-080-500-S08		50	100	8	☑
2LEMG-100-300-S10	10	30	80	10	☑
2LEMG-100-300-110		30	110	10	☑
2LEMG-100-350-S10		35	90	10	☑

Objednací číslo	D (mm)	L1 (mm)	L (mm)	d h5 (mm)	Standardní položka
2LEMG-100-400-S10	10	40	90	10	☑
2LEMG-100-500-S10		50	100	10	☑
2LEMG-100-600-S10		60	110	10	☑
2LEMG-120-300-S12	12	30	90	12	☑
2LEMG-120-350-110		35	110	12	☑
2LEMG-120-400-S12		40	100	12	☑
2LEMG-120-500-S12		50	100	12	☑
2LEMG-120-600-S12		60	110	12	☑
2LEMG-120-700-S12	14	70	130	12	☑
2LEMG-140-500-S14		50	110	14	☑
2LEMG-160-400-160		16	40	160	16
2LEMG-160-550-S16	55		120	16	☑
2LEMG-160-700-S16	70		130	16	☑
2LEMG-160-800-S16	80		160	16	☑
2LEMG-200-500-160	20	50	160	20	☑
2LEMG-200-600-S20		60	130	20	☑
2LEMG-200-1000-S20		100	200	20	☑
2LEMG-250-750-S25	25	75	160	25	☑

4HCEG 4-břité OSTRÉ frézy pro široký sortiment ocelí do HRC 52

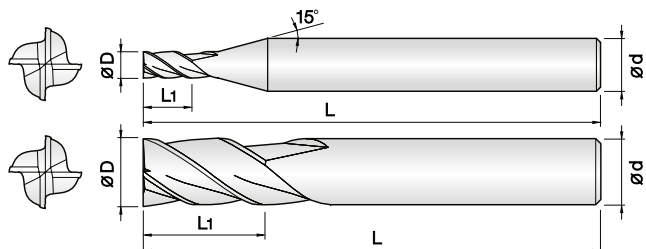

- ▶ Určeno pro široký sortiment různých typů ocelí do HRC 52
- ▶ Optimální pro různé typy ocelí díky AlCrN povlaku
- ▶ Velmi přesné tolerance řezných hran
- ▶ Minimalizace vyštipování díky tvrdokovu s vysokou houževnatostí



Objednací číslo	D (mm)	L1 (mm)	L (mm)	d h5 (mm)	Standardní položka
4HCEG-008-020-S04	0,8	2	40	4	☑
4HCEG-010-010-S04	1	1	40	4	☑
4HCEG-010-025-S04		2,5	40	4	☑
4HCEG-010-025-S06		2,5	40	6	☑
4HCEG-010-025-060		2,5	60	6	☑
4HCEG-010-025-080		2,5	80	6	☑
4HCEG-010-040-S06		4	50	6	☑
4HCEG-012-012-S04		1,2	1,2	40	4
4HCEG-012-030-S04	3		40	4	☑
4HCEG-012-030-S06	3		40	6	☑
4HCEG-012-030-060	3		60	6	☑
4HCEG-012-060-S06	6		50	6	☑
4HCEG-015-015-S04	1,5	1,5	40	4	☑
4HCEG-015-040-S04		4	40	4	☑
4HCEG-015-040-S06		4	40	6	☑
4HCEG-015-040-060		4	60	6	☑
4HCEG-015-040-080		4	80	6	☑
4HCEG-020-020-S04	2	2	40	4	☑
4HCEG-020-060-S04		6	40	4	☑
4HCEG-020-060-S06		6	40	6	☑
4HCEG-020-060-060		6	60	6	☑
4HCEG-020-060-100		6	100	6	☑
4HCEG-025-080-S04	2,5	8	45	4	☑
4HCEG-025-080-S06		8	45	6	☑
4HCEG-025-080-070		8	70	6	☑
4HCEG-025-080-100		8	100	6	☑
4HCEG-030-080-S03	3	8	45	3	☑
4HCEG-030-080-S04		8	45	4	☑
4HCEG-030-080-S06		8	45	6	☑
4HCEG-030-080-070		8	70	6	☑
4HCEG-030-080-100		8	100	6	☑
4HCEG-035-100-S06	3,5	10	45	6	☑
4HCEG-040-040-S04	4	4	40	4	☑
4HCEG-040-110-S04		11	45	4	☑
4HCEG-040-110-S06		11	45	6	☑
4HCEG-040-110-070		11	70	6	☑
4HCEG-040-110-100		11	100	6	☑
4HCEG-045-110-S06	4,5	11	45	6	☑

Objednací číslo	D (mm)	L1 (mm)	L (mm)	d h5 (mm)	Standardní položka
4HCEG-050-130-S06	5	13	50	6	☑
4HCEG-050-130-080		13	80	6	☑
4HCEG-050-130-100		13	100	6	☑
4HCEG-055-130-S06	5,5	13	50	6	☑
4HCEG-060-060-S06	6	6	45	6	☑
4HCEG-060-130-S06		13	50	6	☑
4HCEG-060-130-080		13	80	6	☑
4HCEG-060-130-100		13	100	6	☑
4HCEG-060-150-S06		15	60	6	☑
4HCEG-065-160-S08	6,5	16	60	8	☑
4HCEG-070-160-S08	7	16	60	8	☑
4HCEG-075-160-S08	7,5	16	60	8	☑
4HCEG-080-080-S08	8	8	50	8	☑
4HCEG-080-190-S08		19	60	8	☑
4HCEG-080-200-S08		20	70	8	☑
4HCEG-085-190-S10	8,5	19	70	10	☑
4HCEG-090-190-S10	9	19	70	10	☑
4HCEG-095-190-S10	9,5	19	70	10	☑
4HCEG-100-100-S10	10	10	60	10	☑
4HCEG-100-220-S10		22	70	10	☑
4HCEG-100-250-S10		25	75	10	☑
4HCEG-105-220-S12	10,5	22	75	12	☑
4HCEG-110-220-S12	11	22	75	12	☑
4HCEG-115-220-S12	11,5	22	75	12	☑
4HCEG-120-120-S12	12	12	65	12	☑
4HCEG-120-260-S12		26	75	12	☑
4HCEG-120-300-S12		30	80	12	☑
4HCEG-140-260-S14	14	26	80	14	☑
4HCEG-140-260-S16		26	85	16	☑
4HCEG-160-350-S16	16	35	100	16	☑
4HCEG-160-400-S16		40	100	16	☑
4HCEG-180-350-S18	18	35	100	18	☑
4HCEG-200-400-S20	20	40	100	20	☑
4HCEG-200-450-S20		45	100	20	☑

4LEMG 4-břité OSTRÉ frézy dlouhé pro široký sortiment ocelí do HRC 52

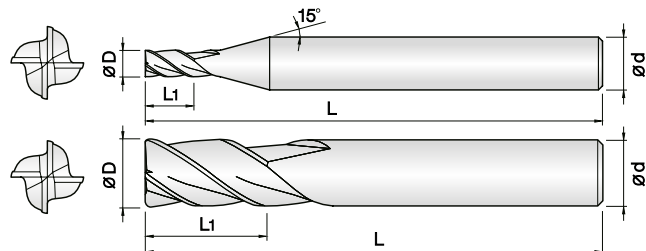

- Určeno pro široký sortiment různých typů ocelí do HRC 52
- Optimální pro různé typy ocelí díky AlCrN povlaku
- Široký sortiment délek pro optimální volbu nástroje
- Minimalizace vyštipování díky tvrdokovu s vysokou houževnatostí

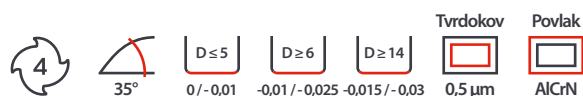

Objednací číslo	D (mm)	L1 (mm)	L (mm)	d h5 (mm)	Standardní položka
4LEMG-010-030-S06	1	3	60	6	☑
4LEMG-010-050-S06		5	60	6	☑
4LEMG-015-060-S06	1,5	6	60	6	☑
4LEMG-015-080-S06		8	60	6	☑
4LEMG-020-080-S06	2	8	60	6	☑
4LEMG-020-100-S06		10	60	6	☑
4LEMG-030-100-S06	3	10	70	6	☑
4LEMG-030-150-S06		15	70	6	☑
4LEMG-030-200-S06		20	70	6	☑
4LEMG-030-250-S06		25	70	6	☑
4LEMG-040-120-S06	4	12	70	6	☑
4LEMG-040-150-S04		15	70	4	☑
4LEMG-040-150-S06		15	70	6	☑
4LEMG-040-200-S04		20	70	4	☑
4LEMG-040-200-S06		20	70	6	☑
4LEMG-040-250-S06		25	70	6	☑
4LEMG-040-300-S06		30	75	6	☑
4LEMG-050-200-S06	5	20	70	6	☑
4LEMG-050-250-S06		25	75	6	☑
4LEMG-050-300-S06		30	80	6	☑
4LEMG-060-200-S06	6	20	75	6	☑
4LEMG-060-200-100		20	100	6	☑
4LEMG-060-250-S06		25	75	6	☑
4LEMG-060-300-S06		30	80	6	☑
4LEMG-060-350-S06		35	80	6	☑
4LEMG-080-250-S08	8	25	75	8	☑
4LEMG-080-250-100		25	100	8	☑
4LEMG-080-300-S08		30	80	8	☑
4LEMG-080-350-S08		35	90	8	☑
4LEMG-080-400-S08		40	90	8	☑
4LEMG-080-450-S08		45	100	8	☑
4LEMG-100-300-S10	10	30	80	10	☑
4LEMG-100-300-110		30	110	10	☑
4LEMG-100-350-S10		35	90	10	☑
4LEMG-100-400-S10		40	90	10	☑
4LEMG-100-500-S10		50	100	10	☑
4LEMG-100-600-S10		60	110	10	☑
4LEMG-120-300-S12	12	30	90	12	☑

Objednací číslo	D (mm)	L1 (mm)	L (mm)	d h5 (mm)	Standardní položka
4LEMG-120-350-110	12	35	110	12	☑
4LEMG-120-400-S12		40	100	12	☑
4LEMG-120-500-S12		50	100	12	☑
4LEMG-120-600-S12		60	110	12	☑
4LEMG-120-700-S12		70	130	12	☑
4LEMG-140-500-S14	14	50	110	14	☑
4LEMG-160-400-160	16	40	160	16	☑
4LEMG-160-550-S16		55	120	16	☑
4LEMG-160-700-S16		70	130	16	☑
4LEMG-180-800-160	18	80	160	18	☑
4LEMG-200-500-160	20	50	160	20	☑
4LEMG-200-600-S20		60	130	20	☑
4LEMG-200-1000-S20		100	200	20	☑
4LEMG-250-750-S25	25	75	160	25	☑

4HEMG 4-břité OSTRÉ frézy 45° pro široký sortiment ocelí do HRC 52

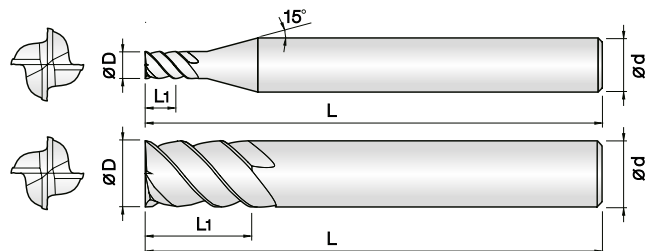

- ▶ Určeno pro široký sortiment různých typů ocelí do HRC 52
- ▶ Optimální pro různé typy ocelí díky AlCrN povlaku
- ▶ Velmi přesné tolerance řezných hran
- ▶ Vyšší posuvy díky 45° geometrii
- ▶ Minimalizace vyštipování díky tvrdokovu s vysokou houževnatostí

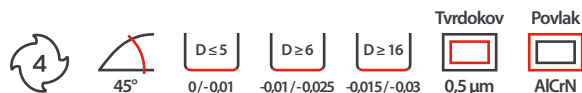

Objednací číslo	D (mm)	L1 (mm)	L (mm)	d h5 (mm)	Standardní položka
4HEMG-010-025-S06	1	2,5	40	6	☑
4HEMG-010-035-S06		3,5	40	6	☑
4HEMG-015-040-S06	1,5	4	40	6	☑
4HEMG-015-060-S06		6	40	6	☑
4HEMG-020-050-S06	2	5	40	6	☑
4HEMG-020-080-S06		8	45	6	☑
4HEMG-030-080-S06	3	8	45	6	☑
4HEMG-030-120-S06		12	50	6	☑
4HEMG-040-110-S06	4	11	45	6	☑
4HEMG-040-160-S06		16	55	6	☑
4HEMG-050-130-S06	5	13	50	6	☑
4HEMG-050-180-S06		18	60	6	☑
4HEMG-060-130-S06	6	13	50	6	☑
4HEMG-060-200-S06		20	60	6	☑
4HEMG-080-200-S08	8	20	60	8	☑
4HEMG-080-250-S08		25	70	8	☑
4HEMG-100-220-S10	10	22	70	10	☑
4HEMG-100-300-S10		30	80	10	☑
4HEMG-120-260-S12	12	26	75	12	☑
4HEMG-120-400-S12		40	90	12	☑
4HEMG-120-500-S12		50	100	12	☑
4HEMG-160-350-S16	16	35	90	16	☑
4HEMG-160-500-S16		50	110	16	☑
4HEMG-200-400-S20	20	40	100	20	☑
4HEMG-200-500-S20		50	110	20	☑

3&4ROUG 3 a 4-břité OSTRÉ frézy hrubovací pro široký sortiment ocelí do HRC 50

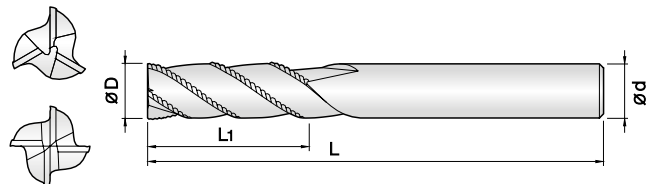

- ▶ Určeno pro široký sortiment různých typů ocelí do HRC 52
- ▶ Optimální pro různé typy ocelí díky AlCrN povlaku
- ▶ Snížení výrobního času díky výbornému utváření třísek
- ▶ Minimalizace vyštipování díky tvrdokovu s vysokou houževnatostí



Objednací číslo	D (mm)	L1 (mm)	L (mm)	d h5 (mm)	Standardní položka
3ROUG-040-100-S06	4	10	50	6	☑
3ROUG-050-130-S06	5	13	50	6	☑
3ROUG-060-100-050	6	10	50	6	☑
3ROUG-060-150-055		15	55	6	☑
3ROUG-060-200-060		20	60	6	☑
3ROUG-070-180-S08	7	18	65	8	☑
3ROUG-080-120-060	8	12	60	8	☑
3ROUG-080-190-065		19	65	8	☑
3ROUG-080-250-070		25	70	8	☑
4ROUG-090-220-S10	9	22	70	10	☑
4ROUG-100-150-070	10	15	70	10	☑
4ROUG-100-220-070		22	70	10	☑
4ROUG-100-300-080		30	80	10	☑
4ROUG-110-270-S12	11	27	80	12	☑
4ROUG-120-200-075	12	20	75	12	☑
4ROUG-120-260-080		26	80	12	☑
4ROUG-120-350-090		35	90	12	☑
4ROUG-160-320-090	16	32	90	16	☑
4ROUG-160-400-100		40	100	16	☑
4ROUG-200-380-110	20	38	110	20	☑
4ROUG-200-500-110		50	110	20	☑

3&4HROUG 3 a 4-břité OSTRÉ frézy hrubovací 45° pro široký sortiment ocelí do HRC 50

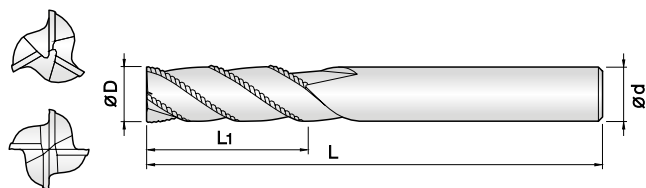

- ▶ Určeno pro široký sortiment různých typů ocelí do HRC 52
- ▶ Optimální pro různé typy ocelí díky AlCrN povlaku
- ▶ Snížení výrobního času díky výbornému utváření třísek
- ▶ Minimalizace vyštipování díky tvrdokovu s vysokou houževnatostí



Objednací číslo	D (mm)	L1 (mm)	L (mm)	d h5 (mm)	Standardní položka
3HROUG-040-100-S06	4	10	50	6	☑
3HROUG-050-130-S06	5	13	50	6	☑
3HROUG-060-100-050	6	10	50	6	☑
3HROUG-060-160-055		16	55	6	☑
3HROUG-060-200-060		20	60	6	☑
3HROUG-070-180-S08	7	18	65	8	☑
3HROUG-080-120-060	8	12	60	8	☑
3HROUG-080-190-065		19	65	8	☑
3HROUG-080-250-070		25	70	8	☑
4HROUG-090-220-S10	9	22	70	10	☑
4HROUG-100-150-070	10	15	70	10	☑
4HROUG-100-220-070		22	70	10	☑
4HROUG-100-300-080		30	80	10	☑
4HROUG-110-270-S12	11	27	80	12	☑
4HROUG-120-200-075	12	20	75	12	☑
4HROUG-120-250-080		25	80	12	☑
4HROUG-120-350-090		35	90	12	☑
4HROUG-160-320-090	16	32	90	16	☑
4HROUG-160-400-110		40	110	16	☑
4HROUG-200-380-110	20	38	110	20	☑
4HROUG-200-500-120		50	120	20	☑

2NCRG 2-břité TOROIDNÍ frézy pro široký sortiment ocelí do HRC 52

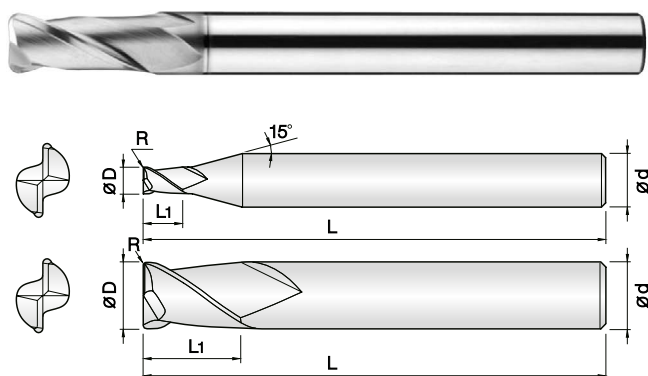

- Určeno pro široký sortiment různých typů ocelí do HRC 52
- Optimální pro různé typy ocelí díky AlCrN povlaku
- Velmi přesné tolerance řezných hran
- Širokový sortiment rádiusů pro optimální volbu nástroje
- Minimalizace vyštipování díky tvrdokovu s vysokou houževnatostí

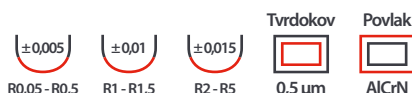
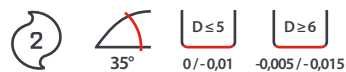

Objednací číslo	D (mm)	R (mm)	L1 (mm)	L (mm)	d h5 (mm)	Standardní položka
2NCRG-004-0005-S04	0,4	R0,05	0,8	45	4	☑
2NCRG-004-001-S04		R0,1	0,8	45	4	☑
2NCRG-005-0005-S04	0,5	R0,05	1	45	4	☑
2NCRG-005-001-S04		R0,1	1	45	4	☑
2NCRG-006-0005-S04	0,6	R0,05	1,2	45	4	☑
2NCRG-006-001-S04		R0,1	1,2	45	4	☑
2NCRG-006-002-S04		R0,2	1,2	45	4	☑
2NCRG-007-0005-S04	0,7	R0,05	1,4	45	4	☑
2NCRG-007-001-S04		R0,1	1,4	45	4	☑
2NCRG-007-002-S04		R0,2	1,4	45	4	☑
2NCRG-008-0005-S04	0,8	R0,05	1,6	45	4	☑
2NCRG-008-001-S04		R0,1	1,6	45	4	☑
2NCRG-008-002-S04		R0,2	1,6	45	4	☑
2NCRG-009-0005-S04	0,9	R0,05	1,8	45	4	☑
2NCRG-009-001-S04		R0,1	1,8	45	4	☑
2NCRG-010-001-S04	1	R0,1	2,5	45	4	☑
2NCRG-010-002-S04		R0,2	2,5	45	4	☑
2NCRG-010-003-S04		R0,3	2,5	45	4	☑
2NCRG-012-001-S04	1,2	R0,1	3,2	45	4	☑
2NCRG-012-002-S04		R0,2	3,2	45	4	☑
2NCRG-012-003-S04		R0,3	3,2	45	4	☑
2NCRG-015-001-S04	1,5	R0,1	4	45	4	☑
2NCRG-015-002-S04		R0,2	4	45	4	☑
2NCRG-015-003-S04		R0,3	4	45	4	☑
2NCRG-015-005-S04	2	R0,5	4	45	4	☑
2NCRG-020-001-S04		R0,1	6	45	4	☑
2NCRG-020-002-S04		R0,2	6	45	4	☑
2NCRG-020-003-S04	2,5	R0,3	6	45	4	☑
2NCRG-020-005-S04		R0,5	6	45	4	☑
2NCRG-025-001-S04		R0,1	6	50	4	☑
2NCRG-025-002-S04	3	R0,2	6	50	4	☑
2NCRG-025-003-S04		R0,3	6	50	4	☑
2NCRG-025-005-S04		R0,5	6	50	4	☑
2NCRG-030-001-S06	3	R0,1	8	60	6	☑
2NCRG-030-002-S06		R0,2	8	60	6	☑
2NCRG-030-003-S06		R0,3	8	60	6	☑
2NCRG-030-005-S06		R0,5	8	60	6	☑
2NCRG-030-010-S06		R1	8	60	6	☑

Objednací číslo	D (mm)	R (mm)	L1 (mm)	L (mm)	d h5 (mm)	Standardní položka
2NCRG-040-001-060	4	R0,1	9	60	4	☑
2NCRG-040-001-080			9	80	4	☑
2NCRG-040-001-100			10	70	6	☑
2NCRG-040-002-060		R0,2	9	60	4	☑
2NCRG-040-002-080			9	80	4	☑
2NCRG-040-002-100			10	70	6	☑
2NCRG-040-003-060		R0,3	9	60	4	☑
2NCRG-040-003-080			9	80	4	☑
2NCRG-040-003-100			10	70	6	☑
2NCRG-040-005-060		R0,5	9	60	4	☑
2NCRG-040-005-080			9	80	4	☑
2NCRG-040-005-100			10	70	6	☑
2NCRG-040-010-060		R1	9	60	4	☑
2NCRG-040-010-080			9	80	4	☑
2NCRG-040-010-100			10	70	6	☑
2NCRG-050-001-060	5	R0,1	13	75	6	☑
2NCRG-050-002-060		R0,2	13	75	6	☑
2NCRG-050-003-060		R0,3	13	75	6	☑
2NCRG-050-005-060		R0,5	13	75	6	☑
2NCRG-050-010-060		R1	13	75	6	☑
2NCRG-060-001-060	6	R0,1	11	60	6	☑
2NCRG-060-001-090			13	90	6	☑
2NCRG-060-002-060		R0,2	11	60	6	☑
2NCRG-060-002-090			13	90	6	☑
2NCRG-060-003-060		R0,3	11	60	6	☑
2NCRG-060-003-090			13	90	6	☑
2NCRG-060-005-060		R0,5	11	60	6	☑
2NCRG-060-005-090			13	90	6	☑
2NCRG-060-010-060		R1	11	60	6	☑
2NCRG-060-010-090			13	90	6	☑
2NCRG-060-015-060		R1,5	11	60	6	☑
2NCRG-060-015-090			13	90	6	☑
2NCRG-060-020-060			R2	11	60	6
2NCRG-060-020-090		13		90	6	☑
2NCRG-060-025-090		R2,5		13	90	6
2NCRG-080-001-070	8	R0,1	16	70	8	☑
2NCRG-080-001-100			19	100	8	☑
2NCRG-080-002-070		R0,2	16	70	8	☑

2NCRG

2-břité TOROIDNÍ frézy pro široký sortiment ocelí do HRC 52

Objednací číslo	D (mm)	R (mm)	L1 (mm)	L (mm)	d h5 (mm)	Standardní položka	
2NCRG-080-002-100	8	R0,2	19	100	8	<input checked="" type="checkbox"/>	
2NCRG-080-003-070		R0,3	16	70	8	<input checked="" type="checkbox"/>	
2NCRG-080-003-100			19	100	8	<input checked="" type="checkbox"/>	
2NCRG-080-005-070		R0,5	16	70	8	<input checked="" type="checkbox"/>	
2NCRG-080-005-100			19	100	8	<input checked="" type="checkbox"/>	
2NCRG-080-005-120			19	120	8	<input checked="" type="checkbox"/>	
2NCRG-080-010-070		R1	16	70	8	<input checked="" type="checkbox"/>	
2NCRG-080-010-100			19	100	8	<input checked="" type="checkbox"/>	
2NCRG-080-010-120			19	120	8	<input checked="" type="checkbox"/>	
2NCRG-080-015-070			R1,5	16	70	8	<input checked="" type="checkbox"/>
2NCRG-080-015-100		19		100	8	<input checked="" type="checkbox"/>	
2NCRG-080-020-070		R2	16	70	8	<input checked="" type="checkbox"/>	
2NCRG-080-020-100			19	100	8	<input checked="" type="checkbox"/>	
2NCRG-080-025-100		R2,5	19	100	8	<input checked="" type="checkbox"/>	
2NCRG-080-030-100		R3	19	100	8	<input checked="" type="checkbox"/>	
2NCRG-080-035-100		R3,5	19	100	8	<input checked="" type="checkbox"/>	
2NCRG-100-001-075		10	R0,1	19	75	10	<input checked="" type="checkbox"/>
2NCRG-100-001-100				22	100	10	<input checked="" type="checkbox"/>
2NCRG-100-002-075			R0,2	19	75	10	<input checked="" type="checkbox"/>
2NCRG-100-002-100				22	100	10	<input checked="" type="checkbox"/>
2NCRG-100-003-075	R0,3		19	75	10	<input checked="" type="checkbox"/>	
2NCRG-100-003-100			22	100	10	<input checked="" type="checkbox"/>	
2NCRG-100-005-075	R0,5		19	75	10	<input checked="" type="checkbox"/>	
2NCRG-100-005-100			22	100	10	<input checked="" type="checkbox"/>	
2NCRG-100-005-130			22	130	10	<input checked="" type="checkbox"/>	
2NCRG-100-010-075	R1		19	75	10	<input checked="" type="checkbox"/>	
2NCRG-100-010-100			22	100	10	<input checked="" type="checkbox"/>	
2NCRG-100-010-130			22	130	10	<input checked="" type="checkbox"/>	
2NCRG-100-015-075	R1,5		19	75	10	<input checked="" type="checkbox"/>	
2NCRG-100-015-100			22	100	10	<input checked="" type="checkbox"/>	
2NCRG-100-015-130			22	130	10	<input checked="" type="checkbox"/>	
2NCRG-100-020-075	R2		19	75	10	<input checked="" type="checkbox"/>	
2NCRG-100-020-100			22	100	10	<input checked="" type="checkbox"/>	
2NCRG-100-025-100	R2,5		22	100	10	<input checked="" type="checkbox"/>	
2NCRG-100-030-100	R3		22	100	10	<input checked="" type="checkbox"/>	
2NCRG-100-040-100	R4		22	100	10	<input checked="" type="checkbox"/>	
2NCRG-120-001-080	12	R0,1	22	80	12	<input checked="" type="checkbox"/>	
2NCRG-120-001-110			26	110	12	<input checked="" type="checkbox"/>	
2NCRG-120-002-080		R0,2	22	80	12	<input checked="" type="checkbox"/>	
2NCRG-120-002-110		R0,2	26	110	12	<input checked="" type="checkbox"/>	
2NCRG-120-003-080		R0,3	22	80	12	<input checked="" type="checkbox"/>	
2NCRG-120-003-110			26	110	12	<input checked="" type="checkbox"/>	
2NCRG-120-005-080		R0,5	22	80	12	<input checked="" type="checkbox"/>	
2NCRG-120-005-110			26	110	12	<input checked="" type="checkbox"/>	
2NCRG-120-005-130			26	130	12	<input checked="" type="checkbox"/>	
2NCRG-120-010-080		R1	22	80	12	<input checked="" type="checkbox"/>	
2NCRG-120-010-110			26	110	12	<input checked="" type="checkbox"/>	
2NCRG-120-010-130			26	130	12	<input checked="" type="checkbox"/>	
2NCRG-120-015-080		R1,5	22	80	12	<input checked="" type="checkbox"/>	
2NCRG-120-015-110			26	110	12	<input checked="" type="checkbox"/>	
2NCRG-120-015-130			26	130	12	<input checked="" type="checkbox"/>	

Objednací číslo	D (mm)	R (mm)	L1 (mm)	L (mm)	d h5 (mm)	Standardní položka
2NCRG-120-020-080	12	R2	22	80	12	<input checked="" type="checkbox"/>
2NCRG-120-020-110			26	110	12	<input checked="" type="checkbox"/>
2NCRG-120-020-130			26	130	12	<input checked="" type="checkbox"/>
2NCRG-120-025-110		R2,5	26	110	12	<input checked="" type="checkbox"/>
2NCRG-120-030-110		R3	26	110	12	<input checked="" type="checkbox"/>
2NCRG-120-040-110		R4	26	110	12	<input checked="" type="checkbox"/>
2NCRG-120-050-110		R5	26	110	12	<input checked="" type="checkbox"/>

4NCRG 4-břité TOROIDNÍ frézy pro široký sortiment ocelí do HRC 52

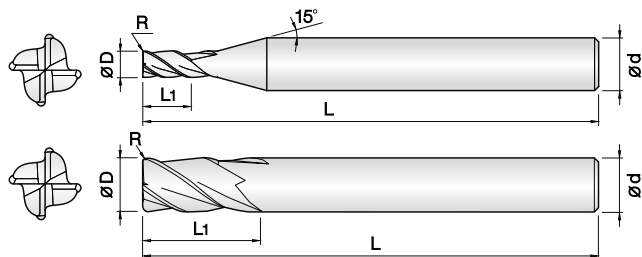

- Určeno pro široký sortiment různých typů ocelí do HRC 52
- Optimální pro různé typy ocelí díky AlCrN povlaku
- Velmi přesné tolerance řezných hran
- Širokový sortiment rádiusů pro optimální volbu nástroje
- Minimalizace vyštipování díky tvrdokovu s vysokou houževnatostí

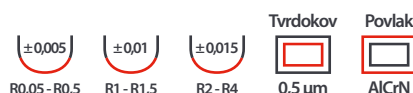

Objednací číslo	D (mm)	R (mm)	L1 (mm)	L (mm)	d h5 (mm)	Standardní položka
4NCRG-010-0005-S04	1	R0,05	2,5	45	4	☑
4NCRG-010-001-S04		R0,1	2,5	45	4	☑
4NCRG-010-002-S04		R0,2	2,5	45	4	☑
4NCRG-010-003-S04		R0,3	2,5	45	4	☑
4NCRG-015-0005-S04	1,5	R0,05	4	45	4	☑
4NCRG-015-001-S04		R0,1	4	45	4	☑
4NCRG-015-002-S04		R0,2	4	45	4	☑
4NCRG-015-003-S04		R0,3	4	45	4	☑
4NCRG-015-005-S04	2	R0,5	4	45	4	☑
4NCRG-020-0005-S04		R0,05	6	45	4	☑
4NCRG-020-001-S04		R0,1	6	45	4	☑
4NCRG-020-002-S04		R0,2	6	45	4	☑
4NCRG-020-003-S04	2,5	R0,3	6	45	4	☑
4NCRG-020-005-S04		R0,5	6	45	4	☑
4NCRG-025-001-S04		R0,1	6	50	4	☑
4NCRG-025-002-S04	3	R0,2	6	50	4	☑
4NCRG-025-003-S04		R0,3	6	50	4	☑
4NCRG-025-005-S04		R0,5	6	50	4	☑
4NCRG-030-001-S06	3	R0,1	8	60	6	☑
4NCRG-030-002-S06		R0,2	8	60	6	☑
4NCRG-030-003-S06		R0,3	8	60	6	☑
4NCRG-030-005-S06		R0,5	8	60	6	☑
4NCRG-030-010-S06	4	R1	8	60	6	☑
4NCRG-040-001-060		R0,1	9	60	4	☑
4NCRG-040-001-080			9	80	4	☑
4NCRG-040-001-S06			10	70	6	☑
4NCRG-040-002-060	R0,2	9	60	4	☑	
4NCRG-040-002-080		9	80	4	☑	
4NCRG-040-002-S06		10	70	6	☑	
4NCRG-040-003-060	R0,3	9	60	4	☑	
4NCRG-040-003-080		9	80	4	☑	
4NCRG-040-003-S06		10	70	6	☑	
4NCRG-040-005-060	R0,5	9	60	4	☑	
4NCRG-040-005-080		9	80	4	☑	
4NCRG-040-005-S06		10	70	6	☑	
4NCRG-040-010-060	R1	9	60	4	☑	
4NCRG-040-010-080		9	80	4	☑	
4NCRG-040-010-S06		10	70	6	☑	

Objednací číslo	D (mm)	R (mm)	L1 (mm)	L (mm)	d h5 (mm)	Standardní položka
4NCRG-050-001-S06	5	R0,1	13	75	6	☑
4NCRG-050-002-S06		R0,2	13	75	6	☑
4NCRG-050-003-S06		R0,3	13	75	6	☑
4NCRG-050-005-S06		R0,5	13	75	6	☑
4NCRG-050-010-S06		R1	13	75	6	☑
4NCRG-060-001-060	6	R0,1	11	60	6	☑
4NCRG-060-001-080			13	80	6	☑
4NCRG-060-002-060		R0,2	11	60	6	☑
4NCRG-060-002-080			13	80	6	☑
4NCRG-060-003-060		R0,3	11	60	6	☑
4NCRG-060-003-080			13	80	6	☑
4NCRG-060-005-060		R0,5	11	60	6	☑
4NCRG-060-005-080			13	80	6	☑
4NCRG-060-010-060		R1	11	60	6	☑
4NCRG-060-010-080			13	80	6	☑
4NCRG-060-015-060		R1,5	11	60	6	☑
4NCRG-060-015-080			13	80	6	☑
4NCRG-060-020-060	R2	11	60	6	☑	
4NCRG-060-020-080		13	80	6	☑	
4NCRG-080-001-070	8	R0,1	16	70	8	☑
4NCRG-080-001-090			19	90	8	☑
4NCRG-080-002-070		R0,2	16	70	8	☑
4NCRG-080-002-090			19	90	8	☑
4NCRG-080-003-070		R0,3	16	70	8	☑
4NCRG-080-003-090			19	90	8	☑
4NCRG-080-005-070		R0,5	16	70	8	☑
4NCRG-080-005-090			19	90	8	☑
4NCRG-080-005-110			19	110	8	☑
4NCRG-080-010-070		R1	16	70	8	☑
4NCRG-080-010-090			19	90	8	☑
4NCRG-080-010-110			19	110	8	☑
4NCRG-080-015-070		R1,5	16	70	8	☑
4NCRG-080-015-090			19	90	8	☑
4NCRG-080-015-110			19	110	8	☑
4NCRG-080-020-070		R2	16	70	8	☑
4NCRG-080-020-090			19	90	8	☑
4NCRG-080-020-110			19	110	8	☑
4NCRG-080-025-090	R2,5	19	90	8	☑	

4NCRG

4-břité TOROIDNÍ frézy pro široký sortiment ocelí do HRC 52

Objednací číslo	D (mm)	R (mm)	L1 (mm)	L (mm)	d h5 (mm)	Standardní položka	
4NCRG-100-001-075	10	R0,1	19	75	10	<input checked="" type="checkbox"/>	
4NCRG-100-001-100			22	100	10	<input checked="" type="checkbox"/>	
4NCRG-100-002-075		R0,2	19	75	10	<input checked="" type="checkbox"/>	
4NCRG-100-002-100			22	100	10	<input checked="" type="checkbox"/>	
4NCRG-100-003-075		R0,3	19	75	10	<input checked="" type="checkbox"/>	
4NCRG-100-003-100			22	100	10	<input checked="" type="checkbox"/>	
4NCRG-100-005-075		R0,5	19	75	10	<input checked="" type="checkbox"/>	
4NCRG-100-005-100			22	100	10	<input checked="" type="checkbox"/>	
4NCRG-100-005-120			22	120	10	<input checked="" type="checkbox"/>	
4NCRG-100-010-075		R1	19	75	10	<input checked="" type="checkbox"/>	
4NCRG-100-010-100			22	100	10	<input checked="" type="checkbox"/>	
4NCRG-100-010-120			22	120	10	<input checked="" type="checkbox"/>	
4NCRG-100-015-075		R1,5	19	75	10	<input checked="" type="checkbox"/>	
4NCRG-100-015-100			22	100	10	<input checked="" type="checkbox"/>	
4NCRG-100-015-120			22	120	10	<input checked="" type="checkbox"/>	
4NCRG-100-020-075		R2	19	75	10	<input checked="" type="checkbox"/>	
4NCRG-100-020-100			22	100	10	<input checked="" type="checkbox"/>	
4NCRG-100-020-120			22	120	10	<input checked="" type="checkbox"/>	
4NCRG-100-025-075		R2,5	19	75	10	<input checked="" type="checkbox"/>	
4NCRG-100-025-100			22	100	10	<input checked="" type="checkbox"/>	
4NCRG-100-025-120			22	120	10	<input checked="" type="checkbox"/>	
4NCRG-100-030-100		R3	22	100	10	<input checked="" type="checkbox"/>	
4NCRG-120-002-080		12	R0,2	22	80	12	<input checked="" type="checkbox"/>
4NCRG-120-002-110				26	110	12	<input checked="" type="checkbox"/>
4NCRG-120-003-080			R0,3	22	80	12	<input checked="" type="checkbox"/>
4NCRG-120-003-110				26	110	12	<input checked="" type="checkbox"/>
4NCRG-120-005-080			R0,5	22	80	12	<input checked="" type="checkbox"/>
4NCRG-120-005-110				26	110	12	<input checked="" type="checkbox"/>
4NCRG-120-005-130	26			130	12	<input checked="" type="checkbox"/>	
4NCRG-120-010-080	R1		22	80	12	<input checked="" type="checkbox"/>	
4NCRG-120-010-110			26	110	12	<input checked="" type="checkbox"/>	
4NCRG-120-010-130			26	130	12	<input checked="" type="checkbox"/>	
4NCRG-120-015-080	R1,5		22	80	12	<input checked="" type="checkbox"/>	
4NCRG-120-015-110			26	110	12	<input checked="" type="checkbox"/>	
4NCRG-120-015-130			26	130	12	<input checked="" type="checkbox"/>	
4NCRG-120-020-080	R2		22	80	12	<input checked="" type="checkbox"/>	
4NCRG-120-020-110			26	110	12	<input checked="" type="checkbox"/>	
4NCRG-120-020-130			26	130	12	<input checked="" type="checkbox"/>	
4NCRG-120-025-080	R2,5		22	80	12	<input checked="" type="checkbox"/>	
4NCRG-120-025-110			26	110	12	<input checked="" type="checkbox"/>	
4NCRG-120-025-130			26	130	12	<input checked="" type="checkbox"/>	
4NCRG-120-030-080	R3		22	80	12	<input checked="" type="checkbox"/>	
4NCRG-120-030-110			26	110	12	<input checked="" type="checkbox"/>	
4NCRG-120-030-130			26	130	12	<input checked="" type="checkbox"/>	
4NCRG-120-035-110	R3,5		26	110	12	<input checked="" type="checkbox"/>	
4NCRG-120-040-110	R4		26	110	12	<input checked="" type="checkbox"/>	
4NCRG-160-005-110	16		R0,5	35	110	16	<input checked="" type="checkbox"/>
4NCRG-160-005-160				35	160	16	<input checked="" type="checkbox"/>
4NCRG-160-010-110			R1	35	110	16	<input checked="" type="checkbox"/>
4NCRG-160-010-160				35	160	16	<input checked="" type="checkbox"/>