



PM-TECH

FRÉZY PRO OBRÁBĚNÍ OCELÍ

50-68HRC



▶ INTERAKTIVNÍ PRVKY



▶ Vhodný prohlížeč

Pro správnou funkci interaktivních prvků doporučujeme k prohlížení katalogu používat program ADOBE READER

Pro snazší orientaci a vyhledávání má katalog následující interaktivní prvky:

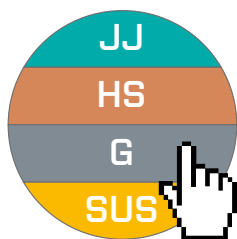

▶ Série fréz v obsahu

Kliknutím na barevné označení série v hlavičce obsahu se dostanete na její první stránku ve výpisu katalogu

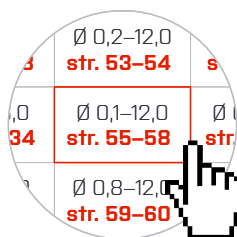

▶ Čísla stránek v obsahu

Pro rychlou navigaci na vybranou kategorii produktů klikněte v obsahu na příslušnou buňku tabulky s číslem stránky



▶ Zpět na obsah z katalogu

Ze kteréhokoliv místa katalogu se snadno dostanete na obsah kliknutím na červené tlačítko „zpět na obsah“ u horního okraje stránky



▶ Odkazy v zápatí stránky

Pokud máte jakékoli dotazy nebo vás zajímají další naše produkty, stačí kliknout na naši e-mailovou adresu, webovou adresu nebo na logo dole na stránce









Typ	Obrázek	Poznámka	Počet břitů	Série fréz pro obrábění ocelí	
				52-68 HRC	50-62 HRC
				JJ	HS
				0,2 μm-VHM TiSiN-S	0,2 μm-VHM TiSiN
Pro žebrování		Kulové	2	Ø 0,1–12,0 str. 8–10	Ø 0,1–12,0 str. 57–59
		Kulové	3	Ø 1,0–12,0 str. 11	
		Kulové–kuželové odlehčení	2	Ø 0,2–12,0 str. 12–15	
		Kulové–kuželové odlehčení	3	Ø 1,0–12,0 str. 16	
		Ostré	2	Ø 0,1–12,0 str. 17–19	Ø 0,1–12,0 str. 60–62
		Ostré	4	Ø 0,5–12,0 str. 20–21	Ø 0,5–12,0 str. 63–64
		Toroidní	2	Ø 0,2–16,0 str. 22–26	Ø 0,2–16,0 str. 65–69
		Toroidní–kuželové odlehčení	2	Ø 1,0–4,0 str. 27–28	
		Toroidní	4	Ø 0,5–12,0 str. 29–31	Ø 0,8–12,0 str. 70–74
		Toroidní	6	Ø 3,0–12,0 str. 32–35	
		Toroidní–kuželové odlehčení	4	Ø 1,0–4,0 str. 36	
Kulové		Krátké	2	Ø 0,1–12,0 str. 37	Ø 0,1–12,0 str. 75
		Standardní	2	Ø 0,1–14,0 str. 38	Ø 0,06–20,0 str. 76–77
		Ultrapřesné	2		Ø 0,2–12,0 str. 78
		Standardní	3	Ø 1,0–12,0 str. 39	Ø 1,0–12,0 str. 79
		Krátké	4	Ø 1,0–12,0 str. 40	Ø 1,0–12,0 str. 81
		Standardní	4	Ø 1,0–20,0 str. 41	Ø 1,0–20,0 str. 80
		Standardní 45°	4		
		230°	2	Ø 1,0–12,0 str. 42	
		230°	4	Ø 1,0–12,0 str. 43	
		270°	4	Ø 1,0–12,0 str. 44	



Typ	Obrázek	Poznámka	Počet břitů	Série fréz pro obrábění ocelí	
				52-68 HRC	50-62 HRC
				JJ	HS
				0,2 μm-VHM TiSiN-S	0,2 μm-VHM TiSiN
Ostré		Krátké	2		Ø 0,1–12,0 str. 82
		Standardní	2	Ø 0,03–20,0 str. 45	Ø 0,05–20,0 str. 83–84
		Dlouhé	2		Ø 1,0–25,0 str. 85–86
		Standardní 45°	3		
		Krátké	4		Ø 0,5–16,0 str. 87
		Standardní	4	Ø 0,3–20,0 str. 46	Ø 0,3–20,0 str. 88
		Dlouhé	4		Ø 0,5–25,0 str. 89–90
		Standardní 35° & 38°	4		
		Standardní 42°	4		
		42°			
		Standardní 45°	4	Ø 1,0–20,0 str. 47	Ø 1,0–25,0 str. 91
		45°	6 & 8	Ø 3,0–25,0 str. 48	Ø 3,0–25,0 str. 92
		Hrubovací	3 & 4		
		Hrubovací 45°	3 & 4 & 5		
	Toroidní			2	Ø 0,2–14,0 str. 49–50
			4	Ø 0,5–16,0 str. 51–52	Ø 0,5–20,0 str. 96–97
		42°	4		
		Dlouhé 42°	4		
		45°	4		Ø 1,0–20,0 str. 98
		45°	6	Ø 3,0–16,0 str. 53	Ø 5,0–16,0 str. 99
		Rychloposuvové 15°	4	Ø 1,0–16,0 str. 54	Ø 1,0–16,0 str. 100
		Rychloposuvové 30°	4 & 6	Ø 1,0–16,0 str. 55	
		Trochoidní 35°	5 & 6		
	42°	7			



Typ	Obrázek	Poznámka	Počet břitů	Série fréz pro obrábění ocelí	
				52-68 HRC	50-62 HRC
				JJ	HS
				0,2 μm-VHM TiSiN-S	0,2 μm-VHM TiSiN
Kuželové		Kulové	2		Ø 0,2–6,0 str. 101–102
		Kulové	3		
		Ostré	2		Ø 0,2–8,0 str. 104–105
		Ostré	4		Ø 3,0–10,0 str. 106
		Pro žebrování	4		Ø 0,5–2,5 str. 107–108
Soudečkové			4 & 6		



- ▶ Tvrđokovové frézy pro kalené oceli do max. tvrdosti HRC 68
- ▶ Vhodné i pro HSC obrábění

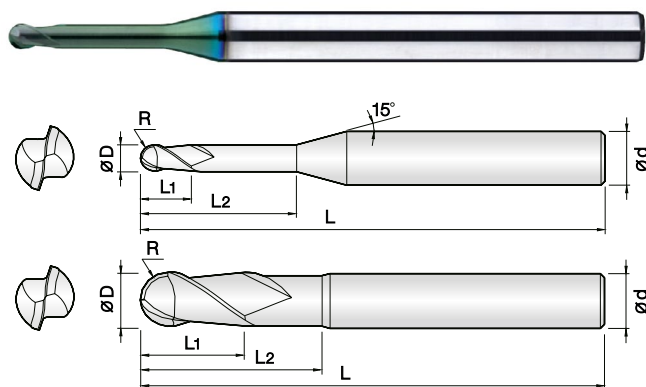

- Určeno pro kalené oceli (52–68 HRC)
- Vysoká odolnost proti opotřeby díky novému PVD povlaku s vysokým obsahem Si
- Velmi přesné tolerance řezných hran
- Široký sortiment vyložení pro optimální výběr nástroje
- Vysoká kvalita obrobeného povrchu
- Vynikající výkon při vysokých řezných rychlostech díky 0,2 μm tvrdkovu

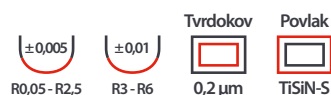
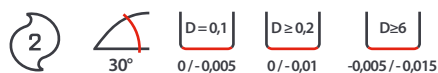

NOVINKA

Objednací číslo	D (mm)	R (mm)	L2 (mm)	L1 (mm)	L (mm)	d h5 (mm)	Standardní položka
2JJRB-001-003-S04	0,1	R 0,05	0,3	0,15	40	4	☑
2JJRB-001-005-S04			0,5	0,15	40	4	☑
2JJRB-0015-003-S04	0,15	R 0,075	0,3	0,15	40	4	☑
2JJRB-0015-005-S04			0,5	0,15	40	4	☑
2JJRB-0015-010-S04			1	0,15	40	4	☑
2JJRB-002-005-S04	0,2	R 0,1	0,5	0,2	40	4	☑
2JJRB-002-010-S04			1	0,2	40	4	☑
2JJRB-002-015-S04			1,5	0,2	40	4	☑
2JJRB-002-020-S04			2	0,2	40	4	☑
2JJRB-002-025-S04			2,5	0,2	40	4	☑
2JJRB-002-030-S04	0,25	R 0,125	3	0,2	40	4	☑
2JJRB-0025-005-S04			0,5	0,25	40	4	☑
2JJRB-0025-010-S04			1	0,25	40	4	☑
2JJRB-0025-015-S04			1,5	0,25	40	4	☑
2JJRB-0025-020-S04			2	0,25	40	4	☑
2JJRB-0025-025-S04			2,5	0,25	40	4	☑
2JJRB-0025-030-S04			3	0,25	40	4	☑
2JJRB-003-010-S04	0,3	R 0,15	1	0,3	40	4	☑
2JJRB-003-015-S04			1,5	0,3	40	4	☑
2JJRB-003-020-S04			2	0,3	40	4	☑
2JJRB-003-025-S04			2,5	0,3	40	4	☑
2JJRB-003-030-S04			3	0,3	40	4	☑
2JJRB-003-035-S04			3,5	0,3	40	4	☑
2JJRB-003-040-S04			4	0,3	40	4	☑
2JJRB-003-050-S04	5	0,3	40	4	☑		
2JJRB-004-010-S04	0,4	R 0,2	1	0,4	40	4	☑
2JJRB-004-015-S04			1,5	0,4	40	4	☑
2JJRB-004-020-S04			2	0,4	40	4	☑
2JJRB-004-025-S04			2,5	0,4	40	4	☑
2JJRB-004-030-S04			3	0,4	40	4	☑
2JJRB-004-035-S04			3,5	0,4	40	4	☑
2JJRB-004-040-S04			4	0,4	40	4	☑
2JJRB-004-045-S04			4,5	0,4	40	4	☑
2JJRB-004-050-S04			5	0,4	40	4	☑
2JJRB-004-060-S04			6	0,4	40	4	☑
2JJRB-004-080-S04	8	0,4	40	4	☑		
2JJRB-005-010-S04	0,5	R 0,25	1	0,5	45	4	☑
2JJRB-005-010-S06			1	0,5	50	6	☑

Objednací číslo	D (mm)	R (mm)	L2 (mm)	L1 (mm)	L (mm)	d h5 (mm)	Standardní položka
2JJRB-005-015-S04	0,5	R 0,25	1,5	0,5	45	4	☑
2JJRB-005-020-S04			2	0,5	45	4	☑
2JJRB-005-020-S06			2	0,5	50	6	☑
2JJRB-005-025-S04			2,5	0,5	45	4	☑
2JJRB-005-030-S04			3	0,5	45	4	☑
2JJRB-005-030-S06			3	0,5	50	6	☑
2JJRB-005-035-S04			3,5	0,5	45	4	☑
2JJRB-005-040-S04			4	0,5	45	4	☑
2JJRB-005-040-S06			4	0,5	50	6	☑
2JJRB-005-045-S04			4,5	0,5	45	4	☑
2JJRB-005-050-S04			5	0,5	45	4	☑
2JJRB-005-050-S06			5	0,5	50	6	☑
2JJRB-005-060-S04	6	0,5	45	4	☑		
2JJRB-005-060-S06	6	0,5	50	6	☑		
2JJRB-005-080-S04	8	0,5	45	4	☑		
2JJRB-005-100-S04	10	0,5	45	4	☑		
2JJRB-005-120-S04	12	0,5	45	4	☑		
2JJRB-006-010-S04	0,6	R 0,3	1	0,6	45	4	☑
2JJRB-006-010-S06			1	0,6	50	6	☑
2JJRB-006-020-S04			2	0,6	45	4	☑
2JJRB-006-020-S06			2	0,6	50	6	☑
2JJRB-006-030-S04			3	0,6	45	4	☑
2JJRB-006-030-S06			3	0,6	50	6	☑
2JJRB-006-040-S04			4	0,6	45	4	☑
2JJRB-006-040-S06			4	0,6	50	6	☑
2JJRB-006-050-S04			5	0,6	45	4	☑
2JJRB-006-050-S06			5	0,6	50	6	☑
2JJRB-006-060-S04			6	0,6	45	4	☑
2JJRB-006-060-S06			6	0,6	50	6	☑
2JJRB-006-080-S04	8	0,6	45	4	☑		
2JJRB-006-080-S06	8	0,6	50	6	☑		
2JJRB-006-100-S04	10	0,6	45	4	☑		
2JJRB-006-120-S04	12	0,6	45	4	☑		
2JJRB-006-140-S04	14	0,6	45	4	☑		
2JJRB-007-020-S04	0,7	R 0,35	2	0,7	45	4	☑
2JJRB-007-040-S04			4	0,7	45	4	☑
2JJRB-007-060-S04			6	0,7	45	4	☑
2JJRB-007-080-S04			8	0,7	45	4	☑

Objednací číslo	D (mm)	R (mm)	L2 (mm)	L1 (mm)	L (mm)	d h5 (mm)	Standardní položka		
2JJRB-007-100-S04	0,7	R 0,35	10	0,7	45	4	☑		
2JJRB-007-120-S04			12	0,7	45	4	☑		
2JJRB-008-020-S04			0,8	R 0,4	2	0,8	45	4	☑
2JJRB-008-020-S06	2	0,8			50	6	☑		
2JJRB-008-030-S04	3	0,8			45	4	☑		
2JJRB-008-030-S06	3	0,8			50	6	☑		
2JJRB-008-040-S04	4	0,8			45	4	☑		
2JJRB-008-040-S06	4	0,8			50	6	☑		
2JJRB-008-050-S04	5	0,8			45	4	☑		
2JJRB-008-050-S06	5	0,8			50	6	☑		
2JJRB-008-060-S04	6	0,8			45	4	☑		
2JJRB-008-060-S06	6	0,8			50	6	☑		
2JJRB-008-080-S04	8	0,8			45	4	☑		
2JJRB-008-080-S06	8	0,8			50	6	☑		
2JJRB-008-100-S04	10	0,8			45	4	☑		
2JJRB-008-120-S04	12	0,8			45	4	☑		
2JJRB-009-040-S04	0,9	R 0,45			4	0,9	45	4	☑
2JJRB-009-060-S04					6	0,9	45	4	☑
2JJRB-009-080-S04					8	0,9	45	4	☑
2JJRB-009-100-S04					10	0,9	50	4	☑
2JJRB-009-120-S04			12	0,9	50	4	☑		
2JJRB-010-020-S04	1	R 0,5	2	1	45	4	☑		
2JJRB-010-020-S06			2	1	50	6	☑		
2JJRB-010-030-S04			3	1	45	4	☑		
2JJRB-010-030-S06			3	1	50	6	☑		
2JJRB-010-040-S04			4	1	45	4	☑		
2JJRB-010-040-S06			4	1	50	6	☑		
2JJRB-010-050-S04			5	1	45	4	☑		
2JJRB-010-050-S06			5	1	50	6	☑		
2JJRB-010-060-S04			6	1	45	4	☑		
2JJRB-010-060-S06			6	1	50	6	☑		
2JJRB-010-080-S04			8	1	45	4	☑		
2JJRB-010-080-S06			8	1	50	6	☑		
2JJRB-010-100-S04			10	1	50	4	☑		
2JJRB-010-100-S06			10	1	50	6	☑		
2JJRB-010-120-S04			12	1	50	4	☑		
2JJRB-010-120-S06			12	1	50	6	☑		
2JJRB-010-140-S04			14	1	50	4	☑		
2JJRB-010-160-S04			16	1	50	4	☑		
2JJRB-010-180-S04			18	1	50	4	☑		
2JJRB-010-200-S04			20	1	50	4	☑		
2JJRB-010-220-S04			22	1	60	4	☑		
2JJRB-010-250-S04			25	1	60	4	☑		
2JJRB-012-040-S04			1,2	R 0,6	4	1,2	45	4	☑
2JJRB-012-040-S06					4	1,2	50	6	☑
2JJRB-012-060-S04					6	1,2	45	4	☑
2JJRB-012-060-S06	6	1,2			50	6	☑		
2JJRB-012-080-S04	8	1,2			45	4	☑		
2JJRB-012-080-S06	8	1,2			50	6	☑		
2JJRB-012-100-S04	10	1,2			50	4	☑		
2JJRB-012-100-S06	10	1,2			50	6	☑		
2JJRB-012-120-S04	12	1,2			50	4	☑		

Objednací číslo	D (mm)	R (mm)	L2 (mm)	L1 (mm)	L (mm)	d h5 (mm)	Standardní položka
2JJRB-012-120-S06	1,2	R 0,6	12	1,2	50	6	☑
2JJRB-012-160-S04			16	1,2	50	4	☑
2JJRB-012-200-S04			20	1,2	50	4	☑
2JJRB-012-240-S04	1,4	R 0,7	24	1,2	60	4	☑
2JJRB-014-060-S04			6	1,4	45	4	☑
2JJRB-014-080-S04			8	1,4	45	4	☑
2JJRB-014-120-S04			12	1,4	50	4	☑
2JJRB-014-160-S04			16	1,4	50	4	☑
2JJRB-015-030-S04			1,5	R 0,75	3	1,5	45
2JJRB-015-030-S06	3	1,5			50	6	☑
2JJRB-015-040-S04	4	1,5			45	4	☑
2JJRB-015-040-S06	4	1,5			50	6	☑
2JJRB-015-060-S04	6	1,5			45	4	☑
2JJRB-015-060-S06	6	1,5			50	6	☑
2JJRB-015-080-S04	8	1,5			45	4	☑
2JJRB-015-080-S06	8	1,5			50	6	☑
2JJRB-015-100-S04	10	1,5			50	4	☑
2JJRB-015-100-S06	10	1,5			50	6	☑
2JJRB-015-120-S04	12	1,5			50	4	☑
2JJRB-015-120-S06	12	1,5			50	6	☑
2JJRB-015-140-S04	14	1,5			50	4	☑
2JJRB-015-140-S06	14	1,5			50	6	☑
2JJRB-015-160-S04	16	1,5			50	4	☑
2JJRB-015-160-S06	16	1,5			60	6	☑
2JJRB-015-180-S04	18	1,5			50	4	☑
2JJRB-015-200-S04	20	1,5			50	4	☑
2JJRB-015-220-S04	22	1,5			60	4	☑
2JJRB-015-250-S04	25	1,5			60	4	☑
2JJRB-015-300-S04	30	1,5	70	4	☑		
2JJRB-016-060-S04	1,6	R 0,8	6	1,6	45	4	☑
2JJRB-016-080-S04			8	1,6	45	4	☑
2JJRB-016-120-S04			12	1,6	50	4	☑
2JJRB-016-160-S04			16	1,6	50	4	☑
2JJRB-016-200-S04			20	1,6	50	4	☑
2JJRB-018-060-S04			1,8	R 0,9	6	1,8	45
2JJRB-018-080-S04	8	1,8			45	4	☑
2JJRB-018-120-S04	12	1,8			50	4	☑
2JJRB-018-160-S04	16	1,8			50	4	☑
2JJRB-018-200-S04	20	1,8			50	4	☑
2JJRB-020-040-S04	2	R 1			4	2	45
2JJRB-020-040-S06			4	2	50	6	☑
2JJRB-020-060-S04			6	2	45	4	☑
2JJRB-020-060-S06			6	2	50	6	☑
2JJRB-020-080-S04			8	2	45	4	☑
2JJRB-020-080-S06			8	2	50	6	☑
2JJRB-020-100-S04			10	2	50	4	☑
2JJRB-020-100-S06			10	2	50	6	☑
2JJRB-020-120-S04			12	2	50	4	☑
2JJRB-020-120-S06			12	2	50	6	☑
2JJRB-020-140-S04			14	2	50	4	☑
2JJRB-020-140-S06			14	2	50	6	☑
2JJRB-020-160-S04	16	2	50	4	☑		

Objednací číslo	D (mm)	R (mm)	L2 (mm)	L1 (mm)	L (mm)	d h5 (mm)	Standardní položka		
2JJRB-020-160-S06	2	R 1	16	2	60	6	<input checked="" type="checkbox"/>		
2JJRB-020-180-S04			18	2	50	4	<input checked="" type="checkbox"/>		
2JJRB-020-180-S06			18	2	60	6	<input checked="" type="checkbox"/>		
2JJRB-020-200-S04			20	2	50	4	<input checked="" type="checkbox"/>		
2JJRB-020-200-S06			20	2	60	6	<input checked="" type="checkbox"/>		
2JJRB-020-220-S04			22	2	60	4	<input checked="" type="checkbox"/>		
2JJRB-020-250-S04			25	2	60	4	<input checked="" type="checkbox"/>		
2JJRB-020-300-S04			30	2	60	4	<input checked="" type="checkbox"/>		
2JJRB-025-080-S04			2,5	R 1,25	8	2,5	45	4	<input checked="" type="checkbox"/>
2JJRB-025-080-S06	8	2,5			50	6	<input checked="" type="checkbox"/>		
2JJRB-025-100-S04	10	2,5			50	4	<input checked="" type="checkbox"/>		
2JJRB-025-100-S06	10	2,5			50	6	<input checked="" type="checkbox"/>		
2JJRB-025-120-S04	12	2,5			50	4	<input checked="" type="checkbox"/>		
2JJRB-025-120-S06	12	2,5			50	6	<input checked="" type="checkbox"/>		
2JJRB-025-160-S04	16	2,5			50	4	<input checked="" type="checkbox"/>		
2JJRB-025-160-S06	16	2,5			60	6	<input checked="" type="checkbox"/>		
2JJRB-025-200-S04	20	2,5			60	4	<input checked="" type="checkbox"/>		
2JJRB-025-200-S06	20	2,5			60	6	<input checked="" type="checkbox"/>		
2JJRB-025-250-S04	25	2,5			60	4	<input checked="" type="checkbox"/>		
2JJRB-025-300-S04	30	2,5			70	4	<input checked="" type="checkbox"/>		
2JJRB-030-060-S06	3	R 1,5			6	3	50	6	<input checked="" type="checkbox"/>
2JJRB-030-080-S06					8	3	50	6	<input checked="" type="checkbox"/>
2JJRB-030-100-S06					10	3	50	6	<input checked="" type="checkbox"/>
2JJRB-030-120-S06			12	3	50	6	<input checked="" type="checkbox"/>		
2JJRB-030-160-S06			16	3	60	6	<input checked="" type="checkbox"/>		
2JJRB-030-200-S06			20	3	60	6	<input checked="" type="checkbox"/>		
2JJRB-030-250-S06			25	3	65	6	<input checked="" type="checkbox"/>		
2JJRB-030-300-S06			30	3	70	6	<input checked="" type="checkbox"/>		
2JJRB-030-350-S06			35	3	75	6	<input checked="" type="checkbox"/>		
2JJRB-030-400-S06			40	3	80	6	<input checked="" type="checkbox"/>		
2JJRB-030-450-S06			45	3	90	6	<input checked="" type="checkbox"/>		
2JJRB-030-500-S06	50	3	100	6	<input checked="" type="checkbox"/>				
2JJRB-035-100-S06	3,5	R 1,75	10	3,5	50	6	<input checked="" type="checkbox"/>		
2JJRB-035-150-S06			15	3,5	60	6	<input checked="" type="checkbox"/>		
2JJRB-035-200-S06			20	3,5	60	6	<input checked="" type="checkbox"/>		
2JJRB-035-250-S06			25	3,5	65	6	<input checked="" type="checkbox"/>		
2JJRB-035-300-S06			30	3,5	70	6	<input checked="" type="checkbox"/>		
2JJRB-035-350-S06			35	3,5	75	6	<input checked="" type="checkbox"/>		
2JJRB-035-400-S06			40	3,5	80	6	<input checked="" type="checkbox"/>		
2JJRB-040-080-S06	4	R 2	8	4	50	6	<input checked="" type="checkbox"/>		
2JJRB-040-100-S06			10	4	50	6	<input checked="" type="checkbox"/>		
2JJRB-040-120-S06			12	4	50	6	<input checked="" type="checkbox"/>		
2JJRB-040-160-S06			16	4	60	6	<input checked="" type="checkbox"/>		
2JJRB-040-200-S06			20	4	60	6	<input checked="" type="checkbox"/>		
2JJRB-040-250-S06			25	4	65	6	<input checked="" type="checkbox"/>		
2JJRB-040-300-S06			30	4	70	6	<input checked="" type="checkbox"/>		
2JJRB-040-350-S06			35	4	75	6	<input checked="" type="checkbox"/>		
2JJRB-040-400-S06			40	4	80	6	<input checked="" type="checkbox"/>		
2JJRB-040-450-S06			45	4	90	6	<input checked="" type="checkbox"/>		
2JJRB-040-500-S06	50	4	100	6	<input checked="" type="checkbox"/>				
2JJRB-050-160-S06	5	R 2,5	16	6	60	6	<input checked="" type="checkbox"/>		
2JJRB-050-200-S06			20	6	60	6	<input checked="" type="checkbox"/>		

Objednací číslo	D (mm)	R (mm)	L2 (mm)	L1 (mm)	L (mm)	d h5 (mm)	Standardní položka
2JJRB-050-250-S06	5	R 2,5	25	6	70	6	<input checked="" type="checkbox"/>
2JJRB-050-300-S06			30	6	75	6	<input checked="" type="checkbox"/>
2JJRB-050-400-S06			40	6	80	6	<input checked="" type="checkbox"/>
2JJRB-050-450-S06			45	6	90	6	<input checked="" type="checkbox"/>
2JJRB-050-500-S06			50	6	100	6	<input checked="" type="checkbox"/>
2JJRB-060-150-S06	6	R 3	15	10	55	6	<input checked="" type="checkbox"/>
2JJRB-060-300-100			30	10	100	6	<input checked="" type="checkbox"/>
2JJRB-060-500-120			50	10	120	6	<input checked="" type="checkbox"/>
2JJRB-080-250-060	8	R 4	25	12	60	8	<input checked="" type="checkbox"/>
2JJRB-080-300-100			30	12	100	8	<input checked="" type="checkbox"/>
2JJRB-080-600-120			60	12	120	8	<input checked="" type="checkbox"/>
2JJRB-100-300-070	10	R 5	30	16	70	10	<input checked="" type="checkbox"/>
2JJRB-100-450-100			45	16	100	10	<input checked="" type="checkbox"/>
2JJRB-100-600-130			60	16	130	10	<input checked="" type="checkbox"/>
2JJRB-120-300-075			30	18	75	12	<input checked="" type="checkbox"/>
2JJRB-120-500-110	12	R 6	50	18	110	12	<input checked="" type="checkbox"/>
2JJRB-120-600-130			60	18	130	12	<input checked="" type="checkbox"/>

3JJRB

3-břité KULOVÉ frézy pro žebrování pro kalené oceli do HRC 68

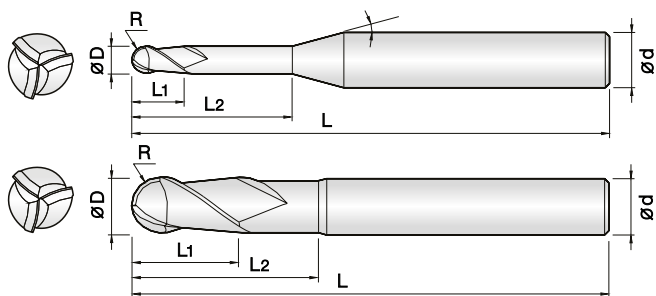

- Určeno pro kalené oceli (52–68 HRC)
- Vysoká odolnost proti opotřebení díky novému PVD povlaku s vysokým obsahem Si
- Velmi přesné tolerance řezných hran
- Široký sortiment vyložení pro optimální výběr nástroje
- Vysoká kvalita obrobeneho povrchu
- Vynikající výkon při vysokých řezných rychlostech díky 0,2 μm tvrdokovu

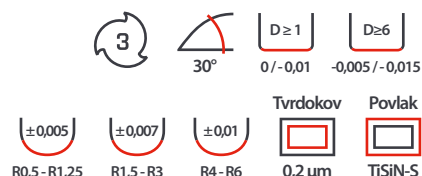

Objednací číslo	D (mm)	R (mm)	L2 (mm)	L1 (mm)	L (mm)	d h5 (mm)	Standardní položka
3JJRB-010-040-S04	1	R 0,5	4	1,2	50	4	☑
3JJRB-010-060-S04			6	1,2	50	4	☑
3JJRB-010-080-S04			8	1,2	50	4	☑
3JJRB-010-100-S04			10	1,2	50	4	☑
3JJRB-010-120-S04			12	1,2	50	4	☑
3JJRB-010-160-S04			16	1,2	50	4	☑
3JJRB-015-060-S04	1,5	R 0,75	6	1,8	50	4	☑
3JJRB-015-080-S04			8	1,8	50	4	☑
3JJRB-015-100-S04			10	1,8	50	4	☑
3JJRB-015-120-S04			12	1,8	50	4	☑
3JJRB-015-160-S04			16	1,8	50	4	☑
3JJRB-015-200-S04			20	1,8	60	4	☑
3JJRB-020-080-S04	2	R 1	8	2,4	50	4	☑
3JJRB-020-100-S04			10	2,4	50	4	☑
3JJRB-020-120-S04			12	2,4	50	4	☑
3JJRB-020-160-S04			16	2,4	50	4	☑
3JJRB-020-200-S04			20	2,4	60	4	☑
3JJRB-020-250-S04			25	2,4	70	4	☑
3JJRB-025-080-S04	2,5	R 1,25	8	3	50	4	☑
3JJRB-025-100-S04			10	3	50	4	☑
3JJRB-025-120-S04			12	3	50	4	☑
3JJRB-025-160-S04			16	3	50	4	☑
3JJRB-025-200-S04			20	3	60	4	☑
3JJRB-025-250-S04			25	3	70	4	☑
3JJRB-030-120-S06	3	R 1,5	12	3,6	60	6	☑
3JJRB-030-160-S06			16	3,6	60	6	☑
3JJRB-030-200-S06			20	3,6	65	6	☑
3JJRB-030-250-S06			25	3,6	70	6	☑
3JJRB-030-300-S06			30	3,6	75	6	☑
3JJRB-030-400-S06			40	3,6	90	6	☑
3JJRB-030-500-S06	50	3,6	100	6	☑		
3JJRB-040-160-S06	4	R 2	16	4,8	60	6	☑
3JJRB-040-200-S06			20	4,8	65	6	☑
3JJRB-040-250-S06			25	4,8	70	6	☑
3JJRB-040-300-S06			30	4,8	75	6	☑
3JJRB-040-400-S06			40	4,8	90	6	☑
3JJRB-040-500-S06			50	4,8	100	6	☑
3JJRB-040-600-S06	60	4,8	110	6	☑		

Objednací číslo	D (mm)	R (mm)	L2 (mm)	L1 (mm)	L (mm)	d h5 (mm)	Standardní položka
3JJRB-050-300-S06	5	R 2,5	30	6	75	6	☑
3JJRB-050-400-S06			40	6	90	6	☑
3JJRB-050-500-S06			50	6	100	6	☑
3JJRB-050-600-S06			60	6	110	6	☑
3JJRB-060-200-060	6	R 3	20	9	60	6	☑
3JJRB-060-300-090			30	9	90	6	☑
3JJRB-080-250-060	8	R 4	25	12	60	8	☑
3JJRB-080-400-100			40	12	100	8	☑
3JJRB-100-300-070	10	R 5	30	15	70	10	☑
3JJRB-100-500-110			50	15	110	10	☑
3JJRB-120-350-075	12	R 6	35	18	75	12	☑
3JJRB-120-600-110			60	18	110	12	☑

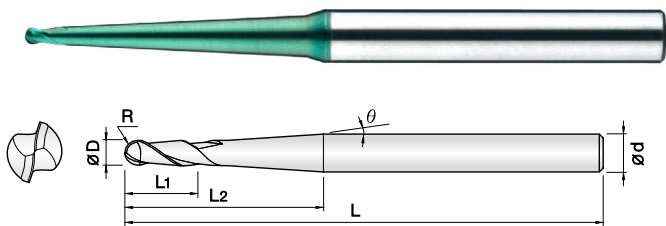

- ▶ **Určeno pro kalené oceli (52–68 HRC)**
- ▶ Vysoká odolnost proti opotřeбенí díky PVD povlaku na bázi Si
- ▶ Velmi přesné tolerance rezných hran
- ▶ Široký sortiment vyložení a úhlů pro optimální výběr nástroje
- ▶ Vysoká tuhost díky kuželovému odlehčení
- ▶ Vynikající výkon při vysokých rezných rychlostech díky 0,2 μm tvrdkovu

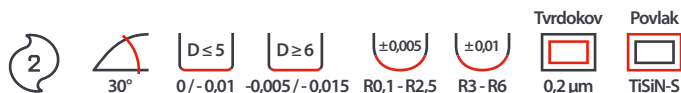

NOVINKA

Objednáací číslo	D (mm)	R (mm)	Úhel θ	L2 (mm)	L1 (mm)	L (mm)	d h5 (mm)	Standardní položka
2JJTB-002-003-015	0,2	R 0,1	0°30'	1,5	0,2	40	4	☑
2JJTB-002-003-020			0°30'	2	0,2	40	4	☑
2JJTB-002-010-015			1°	1,5	0,2	40	4	☑
2JJTB-002-010-020			1°	2	0,2	40	4	☑
2JJTB-002-010-025			1°	2,5	0,2	40	4	☑
2JJTB-002-013-015			1°30'	1,5	0,2	40	4	☑
2JJTB-002-013-020			1°30'	2	0,2	40	4	☑
2JJTB-002-013-025			1°30'	2,5	0,2	40	4	☑
2JJTB-002-020-015			2°	1,5	0,2	40	4	☑
2JJTB-002-020-020			2°	2	0,2	40	4	☑
2JJTB-002-020-025			2°	2,5	0,2	40	4	☑
2JJTB-002-030-015			3°	1,5	0,2	40	4	☑
2JJTB-002-030-020			3°	2	0,2	40	4	☑
2JJTB-002-030-025			3°	2,5	0,2	40	4	☑
2JJTB-002-030-030			3°	3	0,2	45	4	☑
2JJTB-002-050-020			5°	2	0,2	40	4	☑
2JJTB-002-050-030	5°	3	0,2	45	4	☑		
2JJTB-003-003-030	0,3	R 0,15	0°30'	3	0,3	40	4	☑
2JJTB-003-010-020			1°	2	0,3	40	4	☑
2JJTB-003-010-030			1°	3	0,3	40	4	☑
2JJTB-003-010-040			1°	4	0,3	40	4	☑
2JJTB-003-010-050			1°	5	0,3	40	4	☑
2JJTB-003-013-020			1°30'	2	0,3	40	4	☑
2JJTB-003-013-030			1°30'	3	0,3	40	4	☑
2JJTB-003-013-040			1°30'	4	0,3	40	4	☑
2JJTB-003-013-050			1°30'	5	0,3	40	4	☑
2JJTB-003-020-020			2°	2	0,3	40	4	☑
2JJTB-003-020-030			2°	3	0,3	40	4	☑
2JJTB-003-020-040			2°	4	0,3	40	4	☑
2JJTB-003-020-050			2°	5	0,3	40	4	☑
2JJTB-003-020-060			2°	6	0,3	45	4	☑
2JJTB-003-030-020			3°	2	0,3	40	4	☑
2JJTB-003-030-030			3°	3	0,3	40	4	☑
2JJTB-003-030-040	3°	4	0,3	40	4	☑		
2JJTB-003-030-050	3°	5	0,3	40	4	☑		
2JJTB-003-030-060	3°	6	0,3	45	4	☑		
2JJTB-003-050-050	5°	5	0,3	40	4	☑		
2JJTB-003-050-080	5°	8	0,3	45	4	☑		

Objednáací číslo	D (mm)	R (mm)	Úhel θ	L2 (mm)	L1 (mm)	L (mm)	d h5 (mm)	Standardní položka
2JJTB-004-003-020	0,4	R 0,2	0°30'	2	0,4	40	4	☑
2JJTB-004-003-030			0°30'	3	0,4	40	4	☑
2JJTB-004-003-040			0°30'	4	0,4	40	4	☑
2JJTB-004-003-050			0°30'	5	0,4	40	4	☑
2JJTB-004-003-060			0°30'	6	0,4	40	4	☑
2JJTB-004-010-020			1°	2	0,4	40	4	☑
2JJTB-004-010-030			1°	3	0,4	40	4	☑
2JJTB-004-010-040			1°	4	0,4	40	4	☑
2JJTB-004-010-050			1°	5	0,4	40	4	☑
2JJTB-004-010-060			1°	6	0,4	40	4	☑
2JJTB-004-010-080			1°	8	0,4	45	4	☑
2JJTB-004-013-020			1°30'	2	0,4	40	4	☑
2JJTB-004-013-030			1°30'	3	0,4	40	4	☑
2JJTB-004-013-040			1°30'	4	0,4	40	4	☑
2JJTB-004-013-050			1°30'	5	0,4	40	4	☑
2JJTB-004-013-060			1°30'	6	0,4	40	4	☑
2JJTB-004-013-080	1°30'	8	0,4	45	4	☑		
2JJTB-004-020-020	2°	2	0,4	40	4	☑		
2JJTB-004-020-030	2°	3	0,4	40	4	☑		
2JJTB-004-020-040	2°	4	0,4	40	4	☑		
2JJTB-004-020-050	2°	5	0,4	40	4	☑		
2JJTB-004-020-060	2°	6	0,4	40	4	☑		
2JJTB-004-020-080	2°	8	0,4	45	4	☑		
2JJTB-004-020-100	2°	10	0,4	45	4	☑		
2JJTB-004-030-040	3°	4	0,4	45	4	☑		
2JJTB-004-030-060	3°	6	0,4	45	4	☑		
2JJTB-004-030-080	3°	8	0,4	45	4	☑		
2JJTB-004-030-100	3°	10	0,4	45	4	☑		
2JJTB-004-050-060	5°	6	0,4	45	4	☑		
2JJTB-004-050-080	5°	8	0,4	45	4	☑		
2JJTB-004-050-100	5°	10	0,4	45	4	☑		
2JJTB-005-003-040	0,5	R 0,25	0°30'	4	0,5	45	4	☑
2JJTB-005-003-060			0°30'	6	0,5	45	4	☑
2JJTB-005-010-040			1°	4	0,5	45	4	☑
2JJTB-005-010-060			1°	6	0,5	45	4	☑
2JJTB-005-010-080			1°	8	0,5	45	4	☑
2JJTB-005-010-100			1°	10	0,5	45	4	☑
2JJTB-005-013-040			1°30'	4	0,5	45	4	☑

NOVINKA

Objednací číslo	D (mm)	R (mm)	Úhel θ	L2 (mm)	L1 (mm)	L (mm)	d h5 (mm)	Standardní položka
2JJTB-005-013-060	0,5	R 0,25	1°30'	6	0.5	45	4	<input checked="" type="checkbox"/>
2JJTB-005-013-080			1°30'	8	0.5	45	4	<input checked="" type="checkbox"/>
2JJTB-005-013-100			1°30'	10	0.5	45	4	<input checked="" type="checkbox"/>
2JJTB-005-020-040			2°	4	0.5	45	4	<input checked="" type="checkbox"/>
2JJTB-005-020-060			2°	6	0.5	45	4	<input checked="" type="checkbox"/>
2JJTB-005-020-080			2°	8	0.5	45	4	<input checked="" type="checkbox"/>
2JJTB-005-020-100			2°	10	0.5	45	4	<input checked="" type="checkbox"/>
2JJTB-005-030-080			3°	8	0.5	45	4	<input checked="" type="checkbox"/>
2JJTB-005-030-120			3°	12	0.5	50	4	<input checked="" type="checkbox"/>
2JJTB-005-030-160			3°	16	0.5	60	4	<input checked="" type="checkbox"/>
2JJTB-005-030-200			3°	20	0.5	60	4	<input checked="" type="checkbox"/>
2JJTB-005-050-100			5°	10	0.5	50	4	<input checked="" type="checkbox"/>
2JJTB-005-050-150			5°	15	0.5	60	4	<input checked="" type="checkbox"/>
2JJTB-005-050-200			5°	20	0.5	60	4	<input checked="" type="checkbox"/>
2JJTB-006-003-040	0,6	R 0,3	0°30'	4	0.6	45	4	<input checked="" type="checkbox"/>
2JJTB-006-003-060			0°30'	6	0.6	45	4	<input checked="" type="checkbox"/>
2JJTB-006-003-080			0°30'	8	0.6	45	4	<input checked="" type="checkbox"/>
2JJTB-006-010-040			1°	4	0.6	45	4	<input checked="" type="checkbox"/>
2JJTB-006-010-060			1°	6	0.6	45	4	<input checked="" type="checkbox"/>
2JJTB-006-010-080			1°	8	0.6	45	4	<input checked="" type="checkbox"/>
2JJTB-006-010-100			1°	10	0.6	45	4	<input checked="" type="checkbox"/>
2JJTB-006-010-120			1°	12	0.6	50	4	<input checked="" type="checkbox"/>
2JJTB-006-010-150			1°	15	0.6	50	4	<input checked="" type="checkbox"/>
2JJTB-006-010-200			1°	20	0.6	60	4	<input checked="" type="checkbox"/>
2JJTB-006-013-040			1°30'	4	0.6	45	4	<input checked="" type="checkbox"/>
2JJTB-006-013-060			1°30'	6	0.6	45	4	<input checked="" type="checkbox"/>
2JJTB-006-013-080			1°30'	8	0.6	45	4	<input checked="" type="checkbox"/>
2JJTB-006-013-100			1°30'	10	0.6	45	4	<input checked="" type="checkbox"/>
2JJTB-006-013-120			1°30'	12	0.6	50	4	<input checked="" type="checkbox"/>
2JJTB-006-013-150			1°30'	15	0.6	50	4	<input checked="" type="checkbox"/>
2JJTB-006-013-200			1°30'	20	0.6	60	4	<input checked="" type="checkbox"/>
2JJTB-006-020-060			2°	6	0.6	45	4	<input checked="" type="checkbox"/>
2JJTB-006-020-080			2°	8	0.6	45	4	<input checked="" type="checkbox"/>
2JJTB-006-020-100			2°	10	0.6	45	4	<input checked="" type="checkbox"/>
2JJTB-006-020-150			2°	15	0.6	50	4	<input checked="" type="checkbox"/>
2JJTB-006-020-200			2°	20	0.6	60	4	<input checked="" type="checkbox"/>
2JJTB-006-030-130			3°	13	0.6	50	4	<input checked="" type="checkbox"/>
2JJTB-006-030-160			3°	16	0.6	60	4	<input checked="" type="checkbox"/>
2JJTB-006-030-200			3°	20	0.6	60	4	<input checked="" type="checkbox"/>
2JJTB-006-050-100			5°	10	0.6	50	4	<input checked="" type="checkbox"/>
2JJTB-006-050-150			5°	15	0.6	60	4	<input checked="" type="checkbox"/>
2JJTB-006-050-200			5°	20	0.6	60	4	<input checked="" type="checkbox"/>
2JJTB-008-003-040	0,8	R 0,4	0°30'	4	0.8	45	4	<input checked="" type="checkbox"/>
2JJTB-008-003-060			0°30'	6	0.8	45	4	<input checked="" type="checkbox"/>
2JJTB-008-003-080			0°30'	8	0.8	45	4	<input checked="" type="checkbox"/>
2JJTB-008-003-100			0°30'	10	0.8	45	4	<input checked="" type="checkbox"/>
2JJTB-008-003-120			0°30'	12	0.8	50	4	<input checked="" type="checkbox"/>
2JJTB-008-003-150			0°30'	15	0.8	50	4	<input checked="" type="checkbox"/>
2JJTB-008-003-200			0°30'	20	0.8	60	4	<input checked="" type="checkbox"/>
2JJTB-008-003-250			0°30'	25	0.8	70	4	<input checked="" type="checkbox"/>
2JJTB-008-010-040			1°	4	0.8	45	4	<input checked="" type="checkbox"/>
2JJTB-008-010-060			1°	6	0.8	45	4	<input checked="" type="checkbox"/>

Objednací číslo	D (mm)	R (mm)	Úhel θ	L2 (mm)	L1 (mm)	L (mm)	d h5 (mm)	Standardní položka		
2JJTB-008-010-080	0,8	R 0,4	1°	8	0.8	45	4	<input checked="" type="checkbox"/>		
2JJTB-008-010-100			1°	10	0.8	45	4	<input checked="" type="checkbox"/>		
2JJTB-008-010-120			1°	12	0.8	50	4	<input checked="" type="checkbox"/>		
2JJTB-008-010-160			1°	16	0.8	50	4	<input checked="" type="checkbox"/>		
2JJTB-008-010-200			1°	20	0.8	60	4	<input checked="" type="checkbox"/>		
2JJTB-008-010-250			1°	25	0.8	70	4	<input checked="" type="checkbox"/>		
2JJTB-008-013-040			1°30'	4	0.8	45	4	<input checked="" type="checkbox"/>		
2JJTB-008-013-060			1°30'	6	0.8	45	4	<input checked="" type="checkbox"/>		
2JJTB-008-013-080			1°30'	8	0.8	45	4	<input checked="" type="checkbox"/>		
2JJTB-008-013-100			1°30'	10	0.8	45	4	<input checked="" type="checkbox"/>		
2JJTB-008-013-120			1°30'	12	0.8	50	4	<input checked="" type="checkbox"/>		
2JJTB-008-013-160			1°30'	16	0.8	50	4	<input checked="" type="checkbox"/>		
2JJTB-008-013-200			1°30'	20	0.8	60	4	<input checked="" type="checkbox"/>		
2JJTB-008-013-250			1°30'	25	0.8	70	4	<input checked="" type="checkbox"/>		
2JJTB-008-020-080			2°	8	0.8	50	4	<input checked="" type="checkbox"/>		
2JJTB-008-020-100			2°	10	0.8	50	4	<input checked="" type="checkbox"/>		
2JJTB-008-020-120			2°	12	0.8	50	4	<input checked="" type="checkbox"/>		
2JJTB-008-020-160			2°	16	0.8	50	4	<input checked="" type="checkbox"/>		
2JJTB-008-020-200			2°	20	0.8	60	4	<input checked="" type="checkbox"/>		
2JJTB-008-020-250			2°	25	0.8	70	4	<input checked="" type="checkbox"/>		
2JJTB-008-030-080			3°	8	0.8	50	4	<input checked="" type="checkbox"/>		
2JJTB-008-030-120			3°	12	0.8	50	4	<input checked="" type="checkbox"/>		
2JJTB-008-030-160			3°	16	0.8	50	4	<input checked="" type="checkbox"/>		
2JJTB-008-030-200			3°	20	0.8	60	4	<input checked="" type="checkbox"/>		
2JJTB-008-030-250			3°	25	0.8	70	4	<input checked="" type="checkbox"/>		
2JJTB-008-050-240			5°	24	0.8	60	6	<input checked="" type="checkbox"/>		
2JJTB-010-003-060			1	R 0,5	0°30'	6	1	50	4	<input checked="" type="checkbox"/>
2JJTB-010-003-080					0°30'	8	1	50	4	<input checked="" type="checkbox"/>
2JJTB-010-003-100	0°30'	10			1	50	4	<input checked="" type="checkbox"/>		
2JJTB-010-003-150	0°30'	15			1	50	4	<input checked="" type="checkbox"/>		
2JJTB-010-003-200	0°30'	20			1	60	4	<input checked="" type="checkbox"/>		
2JJTB-010-003-250	0°30'	25			1	60	4	<input checked="" type="checkbox"/>		
2JJTB-010-003-300	0°30'	30			1	70	4	<input checked="" type="checkbox"/>		
2JJTB-010-010-060	1°	6			1	50	4	<input checked="" type="checkbox"/>		
2JJTB-010-010-080	1°	8			1	50	4	<input checked="" type="checkbox"/>		
2JJTB-010-010-100	1°	10			1	50	4	<input checked="" type="checkbox"/>		
2JJTB-010-010-150	1°	15			1	50	4	<input checked="" type="checkbox"/>		
2JJTB-010-010-200	1°	20			1	50	4	<input checked="" type="checkbox"/>		
2JJTB-010-010-250	1°	25			1	60	4	<input checked="" type="checkbox"/>		
2JJTB-010-010-300	1°	30			1	70	4	<input checked="" type="checkbox"/>		
2JJTB-010-010-350	1°	35			1	75	4	<input checked="" type="checkbox"/>		
2JJTB-010-013-060	1°30'	6			1	50	4	<input checked="" type="checkbox"/>		
2JJTB-010-013-080	1°30'	8			1	50	4	<input checked="" type="checkbox"/>		
2JJTB-010-013-100	1°30'	10			1	50	4	<input checked="" type="checkbox"/>		
2JJTB-010-013-150	1°30'	15			1	50	4	<input checked="" type="checkbox"/>		
2JJTB-010-013-200	1°30'	20			1	50	4	<input checked="" type="checkbox"/>		
2JJTB-010-013-250	1°30'	25	1	60	4	<input checked="" type="checkbox"/>				
2JJTB-010-013-300	1°30'	30	1	70	4	<input checked="" type="checkbox"/>				
2JJTB-010-013-350	1°30'	35	1	80	4	<input checked="" type="checkbox"/>				
2JJTB-010-013-400	1°30'	40	1	80	4	<input checked="" type="checkbox"/>				
2JJTB-010-020-150	2°	15	1	50	4	<input checked="" type="checkbox"/>				
2JJTB-010-020-200	2°	20	1	50	4	<input checked="" type="checkbox"/>				

JJ

HS

G

SUS

Objednací číslo	D (mm)	R (mm)	Úhel θ	L2 (mm)	L1 (mm)	L (mm)	d h5 (mm)	Standardní položka
2JJTB-010-020-250	1	R 0,5	2°	25	1	60	4	☑
2JJTB-010-020-300			2°	30	1	70	4	☑
2JJTB-010-020-400			2°	40	1	80	4	☑
2JJTB-010-030-200			3°	20	1	50	4	☑
2JJTB-010-030-300			3°	30	1	70	6	☑
2JJTB-010-030-400			3°	40	1	80	6	☑
2JJTB-010-030-500			3°	50	1	90	6	☑
2JJTB-010-050-230			5°	23	1	60	6	☑
2JJTB-012-003-080			1,2	R 0,6	0°30'	8	1,2	50
2JJTB-012-003-120	0°30'	12			1,2	50	4	☑
2JJTB-012-003-180	0°30'	18			1,2	50	4	☑
2JJTB-012-003-240	0°30'	24			1,2	60	4	☑
2JJTB-012-010-080	1°	8			1,2	50	4	☑
2JJTB-012-010-120	1°	12			1,2	50	4	☑
2JJTB-012-010-180	1°	18			1,2	50	4	☑
2JJTB-012-010-240	1°	24			1,2	60	4	☑
2JJTB-012-013-080	1°30'	8			1,2	50	4	☑
2JJTB-012-013-120	1°30'	12			1,2	50	4	☑
2JJTB-012-013-180	1°30'	18			1,2	50	4	☑
2JJTB-012-013-240	1°30'	24			1,2	60	4	☑
2JJTB-012-020-080	2°	8			1,2	50	4	☑
2JJTB-012-020-120	2°	12			1,2	50	4	☑
2JJTB-012-020-180	2°	18			1,2	50	4	☑
2JJTB-012-020-240	2°	24	1,2	60	4	☑		
2JJTB-015-003-080	1,5	R 0,75	0°30'	8	1,5	50	4	☑
2JJTB-015-003-100			0°30'	10	1,5	50	4	☑
2JJTB-015-003-120			0°30'	12	1,5	50	4	☑
2JJTB-015-003-150			0°30'	15	1,5	50	4	☑
2JJTB-015-003-200			0°30'	20	1,5	60	4	☑
2JJTB-015-003-300			0°30'	30	1,5	70	4	☑
2JJTB-015-003-400			0°30'	40	1,5	80	4	☑
2JJTB-015-010-080			1°	8	1,5	50	4	☑
2JJTB-015-010-100			1°	10	1,5	50	4	☑
2JJTB-015-010-120			1°	12	1,5	50	4	☑
2JJTB-015-010-150			1°	15	1,5	50	4	☑
2JJTB-015-010-200			1°	20	1,5	60	4	☑
2JJTB-015-010-250			1°	25	1,5	60	4	☑
2JJTB-015-010-300			1°	30	1,5	70	4	☑
2JJTB-015-010-400			1°	40	1,5	80	4	☑
2JJTB-015-010-500			1°	50	1,5	90	4	☑
2JJTB-015-013-080			1°30'	8	1,5	50	4	☑
2JJTB-015-013-100			1°30'	10	1,5	50	4	☑
2JJTB-015-013-120			1°30'	12	1,5	50	4	☑
2JJTB-015-013-150			1°30'	15	1,5	50	4	☑
2JJTB-015-013-200			1°30'	20	1,5	60	4	☑
2JJTB-015-013-250			1°30'	25	1,5	60	4	☑
2JJTB-015-013-300			1°30'	30	1,5	70	4	☑
2JJTB-015-013-400			1°30'	40	1,5	80	4	☑
2JJTB-015-013-500			1°30'	50	1,5	90	4	☑
2JJTB-015-020-100			2°	10	1,5	50	4	☑
2JJTB-015-020-150			2°	15	1,5	50	4	☑
2JJTB-015-020-200			2°	20	1,5	60	4	☑

Objednací číslo	D (mm)	R (mm)	Úhel θ	L2 (mm)	L1 (mm)	L (mm)	d h5 (mm)	Standardní položka
2JJTB-015-020-300	1,5	R 0,75	2°	30	1,5	70	4	☑
2JJTB-015-020-400			2°	40	1,5	80	6	☑
2JJTB-015-020-500			2°	50	1,5	90	6	☑
2JJTB-015-030-420			3°	42	1,5	80	6	☑
2JJTB-015-050-250			5°	25	1,5	70	6	☑
2JJTB-020-003-080			2	R 1	0°30'	8	2	50
2JJTB-020-003-120	0°30'	12			2	50	4	☑
2JJTB-020-003-160	0°30'	16			2	50	4	☑
2JJTB-020-003-200	0°30'	20			2	60	4	☑
2JJTB-020-003-300	0°30'	30			2	70	4	☑
2JJTB-020-003-400	0°30'	40			2	80	4	☑
2JJTB-020-003-500	0°30'	50			2	90	4	☑
2JJTB-020-010-080	1°	8			2	50	4	☑
2JJTB-020-010-120	1°	12			2	50	4	☑
2JJTB-020-010-160	1°	16			2	50	4	☑
2JJTB-020-010-200	1°	20			2	60	4	☑
2JJTB-020-010-250	1°	25			2	60	4	☑
2JJTB-020-010-300	1°	30			2	70	4	☑
2JJTB-020-010-350	1°	35			2	75	4	☑
2JJTB-020-010-400	1°	40			2	80	4	☑
2JJTB-020-010-500	1°	50			2	90	4	☑
2JJTB-020-010-600	1°	60			2	100	6	☑
2JJTB-020-013-080	1°30'	8			2	50	4	☑
2JJTB-020-013-120	1°30'	12			2	50	4	☑
2JJTB-020-013-160	1°30'	16			2	50	4	☑
2JJTB-020-013-200	1°30'	20			2	60	4	☑
2JJTB-020-013-250	1°30'	25			2	60	4	☑
2JJTB-020-013-300	1°30'	30			2	70	4	☑
2JJTB-020-013-350	1°30'	35			2	75	6	☑
2JJTB-020-013-400	1°30'	40			2	80	6	☑
2JJTB-020-013-500	1°30'	50			2	90	6	☑
2JJTB-020-013-600	1°30'	60			2	100	6	☑
2JJTB-020-020-300	2°	30			2	70	6	☑
2JJTB-020-020-400	2°	40			2	80	6	☑
2JJTB-020-020-500	2°	50			2	90	6	☑
2JJTB-020-030-300	3°	30	2	70	6	☑		
2JJTB-020-030-400	3°	40	2	80	6	☑		
2JJTB-020-030-500	3°	50	2	90	8	☑		
2JJTB-020-050-250	5°	25	2	60	6	☑		
2JJTB-020-050-380	5°	38	2	80	8	☑		
2JJTB-030-003-160	3	R 1,5	0°30'	16	3	60	6	☑
2JJTB-030-003-200			0°30'	20	3	65	6	☑
2JJTB-030-003-300			0°30'	30	3	70	6	☑
2JJTB-030-003-400			0°30'	40	3	80	6	☑
2JJTB-030-003-500			0°30'	50	3	90	6	☑
2JJTB-030-003-600			0°30'	60	3	100	6	☑
2JJTB-030-010-160			1°	16	3	60	6	☑
2JJTB-030-010-200			1°	20	3	65	6	☑
2JJTB-030-010-300			1°	30	3	70	6	☑
2JJTB-030-010-400			1°	40	3	80	6	☑
2JJTB-030-010-500			1°	50	3	90	6	☑
2JJTB-030-010-600			1°	60	3	100	6	☑

Objednací číslo	D (mm)	R (mm)	Úhel θ	L2 (mm)	L1 (mm)	L (mm)	d h5 (mm)	Standardní položka		
2JJTB-030-010-700	3	R 1,5	1°	70	3	110	6	<input checked="" type="checkbox"/>		
2JJTB-030-013-160			1°30'	16	3	60	6	<input checked="" type="checkbox"/>		
2JJTB-030-013-200			1°30'	20	3	65	6	<input checked="" type="checkbox"/>		
2JJTB-030-013-300			1°30'	30	3	70	6	<input checked="" type="checkbox"/>		
2JJTB-030-013-400			1°30'	40	3	80	6	<input checked="" type="checkbox"/>		
2JJTB-030-013-500			1°30'	50	3	90	6	<input checked="" type="checkbox"/>		
2JJTB-030-013-600			1°30'	60	3	100	6	<input checked="" type="checkbox"/>		
2JJTB-030-013-700			1°30'	70	3	120	8	<input checked="" type="checkbox"/>		
2JJTB-030-020-160			2°	16	3	60	6	<input checked="" type="checkbox"/>		
2JJTB-030-020-200			2°	20	3	65	6	<input checked="" type="checkbox"/>		
2JJTB-030-020-300			2°	30	3	70	6	<input checked="" type="checkbox"/>		
2JJTB-030-020-480			2°	48	3	90	6	<input checked="" type="checkbox"/>		
2JJTB-030-020-600			2°	60	3	110	8	<input checked="" type="checkbox"/>		
2JJTB-030-020-700			2°	70	3	120	8	<input checked="" type="checkbox"/>		
2JJTB-030-030-300			3°	30	3	70	6	<input checked="" type="checkbox"/>		
2JJTB-030-030-500			3°	50	3	90	8	<input checked="" type="checkbox"/>		
2JJTB-030-030-700			3°	70	3	120	10	<input checked="" type="checkbox"/>		
2JJTB-030-050-330			5°	33	3	90	8	<input checked="" type="checkbox"/>		
2JJTB-040-003-600			4	R 2	0°30'	60	4	100	6	<input checked="" type="checkbox"/>
2JJTB-040-003-700					0°30'	70	4	110	6	<input checked="" type="checkbox"/>
2JJTB-040-003-900	0°30'	90			4	130	6	<input checked="" type="checkbox"/>		
2JJTB-040-010-500	1°	50			4	90	6	<input checked="" type="checkbox"/>		
2JJTB-040-010-600	1°	60			4	100	6	<input checked="" type="checkbox"/>		
2JJTB-040-010-700	1°	70			4	120	8	<input checked="" type="checkbox"/>		
2JJTB-040-010-900	1°	90			4	150	8	<input checked="" type="checkbox"/>		
2JJTB-040-013-450	1°30'	45			4	90	6	<input checked="" type="checkbox"/>		
2JJTB-040-013-600	1°30'	60			4	110	8	<input checked="" type="checkbox"/>		
2JJTB-040-013-700	1°30'	70			4	120	8	<input checked="" type="checkbox"/>		
2JJTB-040-030-250	3°	25			4	70	6	<input checked="" type="checkbox"/>		
2JJTB-040-030-420	3°	42			4	100	8	<input checked="" type="checkbox"/>		
2JJTB-040-050-290	5°	29			4	90	8	<input checked="" type="checkbox"/>		
2JJTB-050-010-400	5	R 2,5			1°	40	5	90	8	<input checked="" type="checkbox"/>
2JJTB-050-010-600					1°	60	5	110	8	<input checked="" type="checkbox"/>
2JJTB-050-010-900					1°	90	5	150	8	<input checked="" type="checkbox"/>
2JJTB-050-013-400			1°30'	40	5	90	8	<input checked="" type="checkbox"/>		
2JJTB-050-013-600			1°30'	60	5	110	8	<input checked="" type="checkbox"/>		
2JJTB-050-013-900			1°30'	90	5	150	10	<input checked="" type="checkbox"/>		
2JJTB-050-030-400			3°	40	5	90	8	<input checked="" type="checkbox"/>		
2JJTB-060-010-400			6	R 3	1°	40	9	90	8	<input checked="" type="checkbox"/>
2JJTB-060-010-500	1°	50			9	100	8	<input checked="" type="checkbox"/>		
2JJTB-060-010-600	1°	60			9	110	8	<input checked="" type="checkbox"/>		
2JJTB-060-010-700	1°	70			9	120	10	<input checked="" type="checkbox"/>		
2JJTB-060-010-800	1°	80			9	130	10	<input checked="" type="checkbox"/>		
2JJTB-060-010-1000	1°	100			9	150	10	<input checked="" type="checkbox"/>		
2JJTB-060-013-490	1°30'	49			9	110	8	<input checked="" type="checkbox"/>		
2JJTB-060-013-850	1°30'	85			9	150	10	<input checked="" type="checkbox"/>		
2JJTB-060-020-600	2°	60			9	110	10	<input checked="" type="checkbox"/>		
2JJTB-060-020-900	2°	90			9	150	12	<input checked="" type="checkbox"/>		
2JJTB-060-030-290	3°	29			9	90	8	<input checked="" type="checkbox"/>		
2JJTB-060-050-320	5°	32			9	110	10	<input checked="" type="checkbox"/>		
2JJTB-080-010-500	8	R 4			1°	50	12	100	10	<input checked="" type="checkbox"/>
2JJTB-080-010-600					1°	60	12	110	10	<input checked="" type="checkbox"/>

Objednací číslo	D (mm)	R (mm)	Úhel θ	L2 (mm)	L1 (mm)	L (mm)	d h5 (mm)	Standardní položka
2JJTB-080-010-800	8	R 4	1°	80	12	130	12	<input checked="" type="checkbox"/>
2JJTB-080-010-1000			1°	100	12	150	12	<input checked="" type="checkbox"/>
2JJTB-080-013-520			1°30'	52	12	110	10	<input checked="" type="checkbox"/>
2JJTB-080-013-890			1°30'	89	12	150	12	<input checked="" type="checkbox"/>
2JJTB-080-030-330			3°	33	12	100	10	<input checked="" type="checkbox"/>
2JJTB-100-010-600	10	R 5	1°	60	18	110	12	<input checked="" type="checkbox"/>
2JJTB-100-010-750			1°	75	18	130	12	<input checked="" type="checkbox"/>
2JJTB-100-013-540			1°30'	54	18	130	12	<input checked="" type="checkbox"/>
2JJTB-100-030-370			3°	37	18	110	12	<input checked="" type="checkbox"/>
2JJTB-120-013-850	12	R 6	1°30'	85	22	160	16	<input checked="" type="checkbox"/>
2JJTB-120-030-630			3°	63	22	130	16	<input checked="" type="checkbox"/>

3JJTBS 2-břité KULOVÉ frézy s kuželovým odlehčením pro žebrování pro kalené oceli do HRC 68

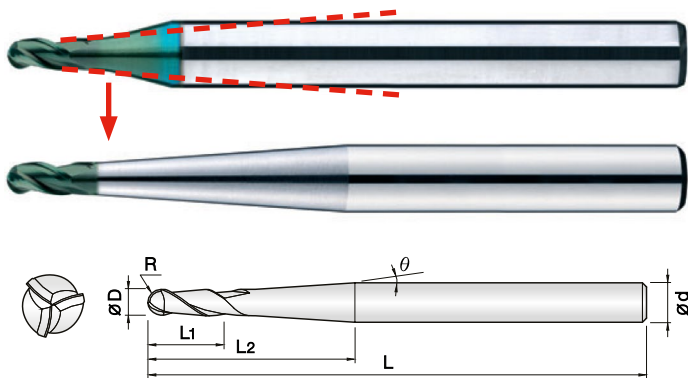

- Určeno pro kalené oceli (52–68 HRC)
- Vysoká odolnost proti opotřebení díky novému PVD povlaku s vysokým obsahem Si
- Velmi přesné tolerance řezných hran
- Rychlá úprava úhlu a délky odlehčení podle Vašich požadavků
- Vynikající výkon při vysokých řezných rychlostech díky 0,2 μm tvrdokovu

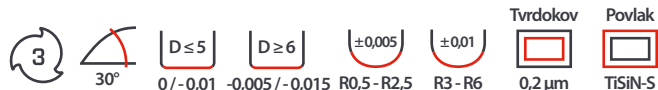

Objednací číslo	D (mm)	R (mm)	Úhel θ	L2 (mm)	L1 (mm)	L (mm)	d h5 (mm)	Standardní položka
3JJTBS-010-060-S04	1	R 0,5	Do objednávky prosím zadejte VÁMI POŽADOVANÝ ÚHEL. Do objednávky prosím zadejte VÁMI POŽADOVANOU DÉLKU ODLEHČENÍ.		1	60	4	<input checked="" type="checkbox"/>
3JJTBS-010-080-S04					1	80	4	<input checked="" type="checkbox"/>
3JJTBS-010-090-S06					1	90	6	<input checked="" type="checkbox"/>
3JJTBS-015-060-S04	1,5	R 0,75		1,5	60	4	<input checked="" type="checkbox"/>	
3JJTBS-015-080-S04				1,5	80	4	<input checked="" type="checkbox"/>	
3JJTBS-015-090-S06				1,5	90	6	<input checked="" type="checkbox"/>	
3JJTBS-020-070-S04	2	R 1		2	70	4	<input checked="" type="checkbox"/>	
3JJTBS-020-090-S04				2	90	4	<input checked="" type="checkbox"/>	
3JJTBS-020-090-S06				2	90	6	<input checked="" type="checkbox"/>	
3JJTBS-030-080-S06	3	R 1,5		3	80	6	<input checked="" type="checkbox"/>	
3JJTBS-030-100-S06				3	100	6	<input checked="" type="checkbox"/>	
3JJTBS-030-110-S08				3	110	8	<input checked="" type="checkbox"/>	
3JJTBS-040-080-S06	4	R 2		5	80	6	<input checked="" type="checkbox"/>	
3JJTBS-040-110-S06				5	110	6	<input checked="" type="checkbox"/>	
3JJTBS-040-120-S08				5	120	8	<input checked="" type="checkbox"/>	
3JJTBS-050-090-S08	5	R 2,5		7	90	8	<input checked="" type="checkbox"/>	
3JJTBS-050-120-S08				7	120	8	<input checked="" type="checkbox"/>	
3JJTBS-060-110-S08	6	R 3		9	110	8	<input checked="" type="checkbox"/>	
3JJTBS-060-150-S10			9	150	10	<input checked="" type="checkbox"/>		
3JJTBS-080-120-S10	8	R 4	12	120	10	<input checked="" type="checkbox"/>		
3JJTBS-080-160-S12			12	160	12	<input checked="" type="checkbox"/>		
3JJTBS-100-120-S12			10	R 5	15	120	12	<input checked="" type="checkbox"/>
3JJTBS-100-160-S12	15	160			12	<input checked="" type="checkbox"/>		
3JJTBS-120-160-S16	12	R 6			18	160	16	<input checked="" type="checkbox"/>
3JJTBS-120-200-S16			18	200	16	<input checked="" type="checkbox"/>		

Příklad objednávky:

Fréza 3JJTBS-010-060-S04
s úhlem odlehčení 1° a délkou odlehčení 20mm

3JJTBS-010-060-S04 θ=1° L2=20mm

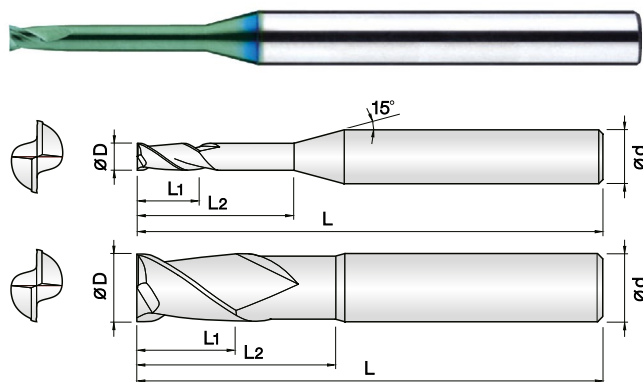

- ▶ **Určeno pro kalené oceli (52–65 HRC)**
- ▶ Vysoká odolnost proti opotřeбенí díky novému PVD povlaku s vysokým obsahem Si
- ▶ Velmi přesné tolerance řezných hran
- ▶ Široký sortiment vyložení pro optimální výběr nástroje
- ▶ Minimalizace vyštipování díky zesílení řezné hrany
- ▶ Vynikající výkon při vysokých řezných rychlostech díky 0,2 μm tvrdokovu

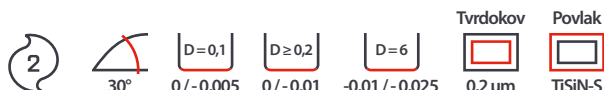

NOVINKA

Objednací číslo	D (mm)	L2 (mm)	L1 (mm)	L (mm)	d h5 (mm)	Standardní položka
2JJRE-001-003-S04	0,1	0,3	0,15	40	4	☑
2JJRE-001-005-S04		0,5	0,15	40	4	☑
2JJRE-0015-003-S04	0,15	0,3	0,15	40	4	☑
2JJRE-0015-005-S04		0,5	0,15	40	4	☑
2JJRE-0015-0075-S04		0,75	0,15	40	4	☑
2JJRE-0015-010-S04	0,2	1	0,15	40	4	☑
2JJRE-002-005-S04		0,5	0,2	40	4	☑
2JJRE-002-010-S04		1	0,2	40	4	☑
2JJRE-002-015-S04		1,5	0,2	40	4	☑
2JJRE-002-020-S04		2	0,2	40	4	☑
2JJRE-002-025-S04		2,5	0,2	40	4	☑
2JJRE-002-030-S04		3	0,2	40	4	☑
2JJRE-0025-005-S04	0,25	0,5	0,25	40	4	☑
2JJRE-0025-010-S04		1	0,25	40	4	☑
2JJRE-0025-015-S04		1,5	0,25	40	4	☑
2JJRE-0025-020-S04		2	0,25	40	4	☑
2JJRE-0025-025-S04		2,5	0,25	40	4	☑
2JJRE-0025-030-S04	3	0,25	40	4	☑	
2JJRE-003-010-S04	0,3	1	0,3	40	4	☑
2JJRE-003-015-S04		1,5	0,3	40	4	☑
2JJRE-003-020-S04		2	0,3	40	4	☑
2JJRE-003-025-S04		2,5	0,3	40	4	☑
2JJRE-003-030-S04		3	0,3	40	4	☑
2JJRE-003-035-S04		3,5	0,3	40	4	☑
2JJRE-003-040-S04		4	0,3	40	4	☑
2JJRE-003-050-S04		5	0,3	40	4	☑
2JJRE-003-060-S04		6	0,3	40	4	☑
2JJRE-003-070-S04		7	0,3	40	4	☑
2JJRE-003-080-S04	8	0,3	40	4	☑	
2JJRE-004-010-S04	0,4	1	0,4	40	4	☑
2JJRE-004-015-S04		1,5	0,4	40	4	☑
2JJRE-004-020-S04		2	0,4	40	4	☑
2JJRE-004-025-S04		2,5	0,4	40	4	☑
2JJRE-004-030-S04		3	0,4	40	4	☑
2JJRE-004-035-S04		3,5	0,4	40	4	☑
2JJRE-004-040-S04		4	0,4	40	4	☑
2JJRE-004-050-S04		5	0,4	40	4	☑
2JJRE-004-060-S04	6	0,4	40	4	☑	

Objednací číslo	D (mm)	L2 (mm)	L1 (mm)	L (mm)	d h5 (mm)	Standardní položka
2JJRE-004-080-S04	0,4	8	0,4	40	4	☑
2JJRE-004-100-S04		10	0,4	45	4	☑
2JJRE-004-120-S04		12	0,4	45	4	☑
2JJRE-005-010-S04	0,5	1	0,5	40	4	☑
2JJRE-005-020-S04		2	0,5	40	4	☑
2JJRE-005-030-S04		3	0,5	40	4	☑
2JJRE-005-040-S04		4	0,5	40	4	☑
2JJRE-005-050-S04		5	0,5	40	4	☑
2JJRE-005-060-S04		6	0,5	40	4	☑
2JJRE-005-080-S04		8	0,5	45	4	☑
2JJRE-005-100-S04		10	0,5	45	4	☑
2JJRE-005-120-S04		12	0,5	45	4	☑
2JJRE-005-140-S04		14	0,5	45	4	☑
2JJRE-005-160-S04	16	0,5	45	4	☑	
2JJRE-006-010-S04	0,6	1	0,6	40	4	☑
2JJRE-006-020-S04		2	0,6	40	4	☑
2JJRE-006-030-S04		3	0,6	40	4	☑
2JJRE-006-040-S04		4	0,6	40	4	☑
2JJRE-006-050-S04		5	0,6	40	4	☑
2JJRE-006-060-S04		6	0,6	40	4	☑
2JJRE-006-080-S04		8	0,6	45	4	☑
2JJRE-006-100-S04		10	0,6	45	4	☑
2JJRE-006-120-S04	12	0,6	45	4	☑	
2JJRE-006-140-S04	14	0,6	45	4	☑	
2JJRE-006-160-S04	16	0,6	45	4	☑	
2JJRE-006-180-S04	18	0,6	50	4	☑	
2JJRE-007-020-S04	0,7	2	0,7	40	4	☑
2JJRE-007-040-S04		4	0,7	40	4	☑
2JJRE-007-060-S04		6	0,7	40	4	☑
2JJRE-007-080-S04		8	0,7	45	4	☑
2JJRE-007-100-S04		10	0,7	45	4	☑
2JJRE-007-120-S04		12	0,7	45	4	☑
2JJRE-007-140-S04	14	0,7	45	4	☑	
2JJRE-007-160-S04	16	0,7	45	4	☑	
2JJRE-008-010-S04	0,8	1	0,8	40	4	☑
2JJRE-008-020-S04		2	0,8	40	4	☑
2JJRE-008-030-S04		3	0,8	40	4	☑
2JJRE-008-040-S04		4	0,8	40	4	☑

NOVINKA

Objednací číslo	D (mm)	L2 (mm)	L1 (mm)	L (mm)	d h5 (mm)	Standardní položka	
2JJRE-008-050-S04	0,8	5	0,8	40	4	☑	
2JJRE-008-060-S04		6	0,8	40	4	☑	
2JJRE-008-080-S04		8	0,8	45	4	☑	
2JJRE-008-100-S04		10	0,8	45	4	☑	
2JJRE-008-120-S04		12	0,8	45	4	☑	
2JJRE-008-140-S04		14	0,8	45	4	☑	
2JJRE-008-160-S04		16	0,8	45	4	☑	
2JJRE-008-180-S04		18	0,8	50	4	☑	
2JJRE-008-200-S04		20	0,8	50	4	☑	
2JJRE-009-040-S04		0,9	4	0,9	40	4	☑
2JJRE-009-060-S04	6		0,9	40	4	☑	
2JJRE-009-080-S04	8		0,9	45	4	☑	
2JJRE-009-100-S04	10		0,9	45	4	☑	
2JJRE-010-020-S04	1		2	1	45	4	☑
2JJRE-010-030-S04		3	1	45	4	☑	
2JJRE-010-040-S04		4	1	45	4	☑	
2JJRE-010-050-S04		5	1	45	4	☑	
2JJRE-010-060-S04		6	1	45	4	☑	
2JJRE-010-080-S04		8	1	45	4	☑	
2JJRE-010-100-S04		10	1	45	4	☑	
2JJRE-010-120-S04		12	1	50	4	☑	
2JJRE-010-140-S04		14	1	50	4	☑	
2JJRE-010-160-S04		16	1	50	4	☑	
2JJRE-010-180-S04		18	1	50	4	☑	
2JJRE-010-200-S04		20	1	50	4	☑	
2JJRE-010-220-S04		22	1	60	4	☑	
2JJRE-010-250-S04		25	1	60	4	☑	
2JJRE-010-300-S04		30	1	70	4	☑	
2JJRE-012-040-S04		1,2	4	1,2	45	4	☑
2JJRE-012-060-S04			6	1,2	45	4	☑
2JJRE-012-080-S04			8	1,2	45	4	☑
2JJRE-012-100-S04			10	1,2	45	4	☑
2JJRE-012-120-S04			12	1,2	50	4	☑
2JJRE-012-160-S04	16		1,2	50	4	☑	
2JJRE-012-200-S04	20		1,2	50	4	☑	
2JJRE-012-250-S04	25		1,2	60	4	☑	
2JJRE-014-080-S04	1,4	8	1,4	45	4	☑	
2JJRE-014-100-S04		10	1,4	45	4	☑	
2JJRE-014-140-S04		14	1,4	50	4	☑	
2JJRE-014-160-S04		16	1,4	50	4	☑	
2JJRE-014-200-S04		20	1,4	50	4	☑	
2JJRE-014-220-S04		22	1,4	60	4	☑	
2JJRE-015-040-S04	1,5	4	1,5	45	4	☑	
2JJRE-015-060-S04		6	1,5	45	4	☑	
2JJRE-015-080-S04		8	1,5	45	4	☑	
2JJRE-015-100-S04		10	1,5	50	4	☑	
2JJRE-015-120-S04		12	1,5	50	4	☑	
2JJRE-015-140-S04		14	1,5	50	4	☑	
2JJRE-015-160-S04		16	1,5	50	4	☑	
2JJRE-015-180-S04		18	1,5	50	4	☑	
2JJRE-015-200-S04		20	1,5	50	4	☑	
2JJRE-015-220-S04		22	1,5	60	4	☑	

Objednací číslo	D (mm)	L2 (mm)	L1 (mm)	L (mm)	d h5 (mm)	Standardní položka
2JJRE-015-250-S04	1,5	25	1,5	60	4	☑
2JJRE-015-350-S04		35	1,5	70	4	☑
2JJRE-015-400-S04		40	1,5	80	4	☑
2JJRE-016-060-S04	1,6	6	1,6	45	4	☑
2JJRE-016-100-S04		10	1,6	50	4	☑
2JJRE-016-140-S04		14	1,6	50	4	☑
2JJRE-016-180-S04		18	1,6	50	4	☑
2JJRE-016-200-S04		20	1,6	50	4	☑
2JJRE-018-100-S04	1,8	10	1,8	50	4	☑
2JJRE-018-120-S04		12	1,8	50	4	☑
2JJRE-018-140-S04		14	1,8	50	4	☑
2JJRE-018-160-S04		16	1,8	50	4	☑
2JJRE-018-180-S04		18	1,8	50	4	☑
2JJRE-018-200-S04		20	1,8	50	4	☑
2JJRE-018-250-S04		25	1,8	60	4	☑
2JJRE-020-060-S04	2	6	2	45	4	☑
2JJRE-020-080-S04		8	2	45	4	☑
2JJRE-020-100-S04		10	2	50	4	☑
2JJRE-020-120-S04		12	2	50	4	☑
2JJRE-020-140-S04		14	2	50	4	☑
2JJRE-020-160-S04		16	2	50	4	☑
2JJRE-020-180-S04		18	2	50	4	☑
2JJRE-020-200-S04		20	2	50	4	☑
2JJRE-020-220-S04		22	2	60	4	☑
2JJRE-020-250-S04		25	2	60	4	☑
2JJRE-020-300-S04		30	2	60	4	☑
2JJRE-020-350-S04		35	2	70	4	☑
2JJRE-020-400-S04		40	2	80	4	☑
2JJRE-020-450-S04		45	2	90	4	☑
2JJRE-020-500-S04		50	2	90	4	☑
2JJRE-025-100-S04	2,5	10	2,5	50	4	☑
2JJRE-025-120-S04		12	2,5	50	4	☑
2JJRE-025-160-S04		16	2,5	50	4	☑
2JJRE-025-200-S04		20	2,5	50	4	☑
2JJRE-025-250-S04		25	2,5	60	4	☑
2JJRE-025-300-S04		30	2,5	70	4	☑
2JJRE-025-350-S04		35	2,5	70	4	☑
2JJRE-025-400-S04		40	2,5	80	4	☑
2JJRE-025-450-S04		45	2,5	90	4	☑
2JJRE-025-500-S04		50	2,5	90	4	☑
2JJRE-030-060-S06	3	6	3	45	6	☑
2JJRE-030-080-S06		8	3	45	6	☑
2JJRE-030-100-S06		10	3	50	6	☑
2JJRE-030-120-S06		12	3	50	6	☑
2JJRE-030-160-S06		16	3	55	6	☑
2JJRE-030-200-S06		20	3	60	6	☑
2JJRE-030-250-S06		25	3	65	6	☑
2JJRE-030-300-S06		30	3	70	6	☑
2JJRE-030-350-S06		35	3	75	6	☑
2JJRE-030-400-S06		40	3	80	6	☑
2JJRE-030-450-S06	45	3	90	6	☑	
2JJRE-030-500-S06	50	3	100	6	☑	

NOVINKA

Objednací číslo	D (mm)	L2 (mm)	L1 (mm)	L (mm)	d h5 (mm)	Standardní položka
2JJRE-030-600-S06	3	60	3	100	6	<input checked="" type="checkbox"/>
2JJRE-035-120-S06	3,5	12	3,5	50	6	<input checked="" type="checkbox"/>
2JJRE-035-160-S06		16	3,5	55	6	<input checked="" type="checkbox"/>
2JJRE-035-200-S06		20	3,5	60	6	<input checked="" type="checkbox"/>
2JJRE-035-250-S06		25	3,5	65	6	<input checked="" type="checkbox"/>
2JJRE-035-300-S06		30	3,5	70	6	<input checked="" type="checkbox"/>
2JJRE-035-350-S06		35	3,5	75	6	<input checked="" type="checkbox"/>
2JJRE-035-400-S06		40	3,5	80	6	<input checked="" type="checkbox"/>
2JJRE-040-080-S06		4	8	4	50	6
2JJRE-040-100-S06	10		4	50	6	<input checked="" type="checkbox"/>
2JJRE-040-120-S06	12		4	50	6	<input checked="" type="checkbox"/>
2JJRE-040-160-S06	16		4	55	6	<input checked="" type="checkbox"/>
2JJRE-040-200-S06	20		4	60	6	<input checked="" type="checkbox"/>
2JJRE-040-250-S06	25		4	65	6	<input checked="" type="checkbox"/>
2JJRE-040-300-S06	30		4	70	6	<input checked="" type="checkbox"/>
2JJRE-040-350-S06	35		4	75	6	<input checked="" type="checkbox"/>
2JJRE-040-400-S06	40		4	80	6	<input checked="" type="checkbox"/>
2JJRE-040-450-S06	45		4	90	6	<input checked="" type="checkbox"/>
2JJRE-040-500-S06	50		4	100	6	<input checked="" type="checkbox"/>
2JJRE-040-600-S06	60		4	100	6	<input checked="" type="checkbox"/>
2JJRE-045-120-S06	4,5	12	4,5	50	6	<input checked="" type="checkbox"/>
2JJRE-045-160-S06		16	4,5	55	6	<input checked="" type="checkbox"/>
2JJRE-045-200-S06		20	4,5	60	6	<input checked="" type="checkbox"/>
2JJRE-045-250-S06		25	4,5	65	6	<input checked="" type="checkbox"/>
2JJRE-045-300-S06		30	4,5	70	6	<input checked="" type="checkbox"/>
2JJRE-045-400-S06		40	4,5	80	6	<input checked="" type="checkbox"/>
2JJRE-050-160-S06	5	16	6	60	6	<input checked="" type="checkbox"/>
2JJRE-050-200-S06		20	6	60	6	<input checked="" type="checkbox"/>
2JJRE-050-250-S06		25	6	65	6	<input checked="" type="checkbox"/>
2JJRE-050-300-S06		30	6	70	6	<input checked="" type="checkbox"/>
2JJRE-050-350-S06		35	6	75	6	<input checked="" type="checkbox"/>
2JJRE-050-400-S06		40	6	80	6	<input checked="" type="checkbox"/>
2JJRE-050-500-S06		50	6	100	6	<input checked="" type="checkbox"/>
2JJRE-050-600-S06		60	6	100	6	<input checked="" type="checkbox"/>
2JJRE-060-200-S06	6	20	10	60	6	<input checked="" type="checkbox"/>
2JJRE-060-300-S06		30	10	75	6	<input checked="" type="checkbox"/>
2JJRE-060-400-S06		40	10	80	6	<input checked="" type="checkbox"/>
2JJRE-060-500-S06		50	10	90	6	<input checked="" type="checkbox"/>
2JJRE-060-600-S06		60	10	110	6	<input checked="" type="checkbox"/>
2JJRE-080-300-S08	8	30	12	80	8	<input checked="" type="checkbox"/>
2JJRE-080-500-S08		50	12	100	8	<input checked="" type="checkbox"/>
2JJRE-100-400-S10	10	40	15	90	10	<input checked="" type="checkbox"/>
2JJRE-100-600-S10		60	15	110	10	<input checked="" type="checkbox"/>
2JJRE-120-500-S12	12	50	18	100	12	<input checked="" type="checkbox"/>
2JJRE-120-700-S12		70	18	120	12	<input checked="" type="checkbox"/>

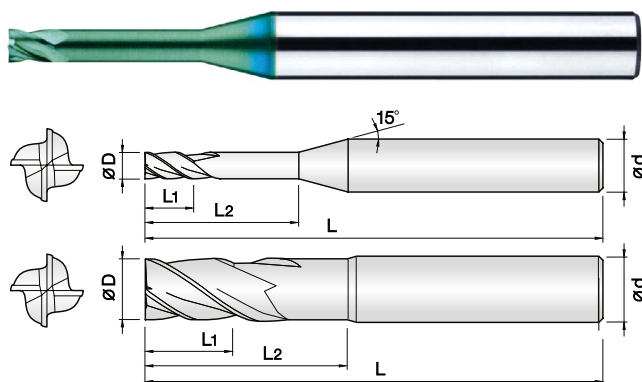

- ▶ **Určeno pro kalené oceli (52–65 HRC)**
- ▶ Vysoká odolnost proti opotřeбенí díky novému PVD povlaku s vysokým obsahem Si
- ▶ Velmi přesné tolerance řezných hran
- ▶ Široký sortiment vyložení pro optimální výběr nástroje
- ▶ Minimalizace vyštipování díky zesílení řezné hrany
- ▶ Vynikající výkon při vysokých řezných rychlostech díky 0,2 μm tvrdokovu

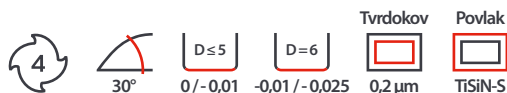

NOVINKA

Objednací číslo	D (mm)	L2 (mm)	L1 (mm)	L (mm)	d h5 (mm)	Standardní položka
4JJRE-005-010-S04	0,5	1	0,5	40	4	☑
4JJRE-005-020-S04		2	0,5	40	4	☑
4JJRE-005-030-S04		3	0,5	45	4	☑
4JJRE-005-040-S04		4	0,5	45	4	☑
4JJRE-005-050-S04		5	0,5	45	4	☑
4JJRE-005-060-S04		6	0,5	45	4	☑
4JJRE-005-080-S04		8	0,5	45	4	☑
4JJRE-005-100-S04		10	0,5	50	4	☑
4JJRE-006-010-S04	0,6	1	0,6	45	4	☑
4JJRE-006-020-S04		2	0,6	45	4	☑
4JJRE-006-030-S04		3	0,6	45	4	☑
4JJRE-006-040-S04		4	0,6	45	4	☑
4JJRE-006-050-S04		5	0,6	45	4	☑
4JJRE-006-060-S04		6	0,6	45	4	☑
4JJRE-006-080-S04		8	0,6	45	4	☑
4JJRE-006-100-S04		10	0,6	50	4	☑
4JJRE-006-120-S04	12	0,6	50	4	☑	
4JJRE-007-020-S04	0,7	2	0,7	45	4	☑
4JJRE-007-040-S04		4	0,7	45	4	☑
4JJRE-007-060-S04		6	0,7	45	4	☑
4JJRE-007-080-S04		8	0,7	45	4	☑
4JJRE-007-100-S04		10	0,7	50	4	☑
4JJRE-008-010-S04	0,8	1	0,8	40	4	☑
4JJRE-008-020-S04		2	0,8	40	4	☑
4JJRE-008-030-S04		3	0,8	40	4	☑
4JJRE-008-040-S04		4	0,8	40	4	☑
4JJRE-008-050-S04		5	0,8	40	4	☑
4JJRE-008-060-S04		6	0,8	40	4	☑
4JJRE-008-080-S04		8	0,8	40	4	☑
4JJRE-008-100-S04		10	0,8	50	4	☑
4JJRE-008-120-S04	12	0,8	50	4	☑	
4JJRE-008-160-S04	16	0,8	50	4	☑	
4JJRE-010-020-S04	1	2	1	45	4	☑
4JJRE-010-030-S04		3	1	45	4	☑
4JJRE-010-040-S04		4	1	45	4	☑
4JJRE-010-060-S04		6	1	45	4	☑
4JJRE-010-080-S04		8	1	45	4	☑
4JJRE-010-100-S04		10	1	50	4	☑

Objednací číslo	D (mm)	L2 (mm)	L1 (mm)	L (mm)	d h5 (mm)	Standardní položka
4JJRE-010-120-S04	1	12	1	50	4	☑
4JJRE-010-140-S04		14	1	50	4	☑
4JJRE-010-160-S04		16	1	50	4	☑
4JJRE-010-180-S04		18	1	60	4	☑
4JJRE-010-200-S04		20	1	60	4	☑
4JJRE-012-040-S04	1,2	4	1,2	45	4	☑
4JJRE-012-060-S04		6	1,2	45	4	☑
4JJRE-012-080-S04		8	1,2	45	4	☑
4JJRE-012-100-S04		10	1,2	50	4	☑
4JJRE-012-120-S04		12	1,2	50	4	☑
4JJRE-012-160-S04	16	1,2	50	4	☑	
4JJRE-012-180-S04	18	1,2	60	4	☑	
4JJRE-012-200-S04	20	1,2	60	4	☑	
4JJRE-014-060-S04	1,4	6	1,4	45	4	☑
4JJRE-014-080-S04		8	1,4	45	4	☑
4JJRE-014-100-S04		10	1,4	50	4	☑
4JJRE-014-120-S04		12	1,4	50	4	☑
4JJRE-014-140-S04		14	1,4	50	4	☑
4JJRE-014-160-S04	16	1,4	50	4	☑	
4JJRE-015-040-S04	1,5	4	1,5	45	4	☑
4JJRE-015-060-S04		6	1,5	45	4	☑
4JJRE-015-080-S04		8	1,5	45	4	☑
4JJRE-015-100-S04		10	1,5	50	4	☑
4JJRE-015-120-S04		12	1,5	50	4	☑
4JJRE-015-160-S04		16	1,5	50	4	☑
4JJRE-015-180-S04		18	1,5	60	4	☑
4JJRE-015-200-S04		20	1,5	60	4	☑
4JJRE-015-250-S04	25	1,5	60	4	☑	
4JJRE-015-300-S04	30	1,5	70	4	☑	
4JJRE-016-060-S04	1,6	6	1,6	45	4	☑
4JJRE-016-080-S04		8	1,6	45	4	☑
4JJRE-016-100-S04		10	1,6	50	4	☑
4JJRE-016-120-S04		12	1,6	50	4	☑
4JJRE-016-140-S04		14	1,6	50	4	☑
4JJRE-016-160-S04		16	1,6	50	4	☑
4JJRE-016-180-S04		18	1,6	60	4	☑
4JJRE-016-200-S04		20	1,6	60	4	☑
4JJRE-016-250-S04	25	1,6	70	4	☑	

NOVINKA

Objednací číslo	D (mm)	L2 (mm)	L1 (mm)	L (mm)	d h5 (mm)	Standardní položka	
4JJRE-018-060-S04	1,8	6	1,8	45	4	☑	
4JJRE-018-080-S04		8	1,8	45	4	☑	
4JJRE-018-100-S04		10	1,8	50	4	☑	
4JJRE-018-120-S04		12	1,8	50	4	☑	
4JJRE-018-160-S04		16	1,8	50	4	☑	
4JJRE-018-200-S04		20	1,8	60	4	☑	
4JJRE-018-250-S04		25	1,8	70	4	☑	
4JJRE-020-040-S04	2	4	2	45	4	☑	
4JJRE-020-060-S04		6	2	45	4	☑	
4JJRE-020-080-S04		8	2	45	4	☑	
4JJRE-020-100-S04		10	2	50	4	☑	
4JJRE-020-120-S04		12	2	50	4	☑	
4JJRE-020-140-S04		14	2	50	4	☑	
4JJRE-020-160-S04		16	2	50	4	☑	
4JJRE-020-180-S04		18	2	50	4	☑	
4JJRE-020-200-S04		20	2	50	4	☑	
4JJRE-020-220-S04		22	2	60	4	☑	
4JJRE-020-250-S04		25	2	60	4	☑	
4JJRE-020-300-S04		30	2	70	4	☑	
4JJRE-025-100-S04		2,5	10	2,5	50	4	☑
4JJRE-025-120-S04			12	2,5	50	4	☑
4JJRE-025-160-S04	16		2,5	50	4	☑	
4JJRE-025-200-S04	20		2,5	50	4	☑	
4JJRE-025-250-S04	25		2,5	60	4	☑	
4JJRE-025-300-S04	30		2,5	70	4	☑	
4JJRE-030-060-S06	3	6	3	45	6	☑	
4JJRE-030-080-S06		8	3	45	6	☑	
4JJRE-030-100-S06		10	3	50	6	☑	
4JJRE-030-120-S06		12	3	50	6	☑	
4JJRE-030-160-S06		16	3	55	6	☑	
4JJRE-030-200-S06		20	3	60	6	☑	
4JJRE-030-250-S06		25	3	65	6	☑	
4JJRE-030-300-S06		30	3	70	6	☑	
4JJRE-030-350-S06		35	3	75	6	☑	
4JJRE-030-400-S06		40	3	80	6	☑	
4JJRE-030-450-S06		45	3	90	6	☑	
4JJRE-030-500-S06		50	3	100	6	☑	
4JJRE-030-600-S06		60	3	110	6	☑	
4JJRE-035-120-S06		3,5	12	3,5	50	6	☑
4JJRE-035-160-S06	16		3,5	55	6	☑	
4JJRE-035-200-S06	20		3,5	60	6	☑	
4JJRE-035-250-S06	25		3,5	65	6	☑	
4JJRE-035-300-S06	30		3,5	70	6	☑	
4JJRE-035-350-S06	35		3,5	75	6	☑	
4JJRE-035-400-S06	40	3,5	80	6	☑		
4JJRE-040-060-S06	4	6	4	50	6	☑	
4JJRE-040-080-S06		8	4	50	6	☑	
4JJRE-040-100-S06		10	4	50	6	☑	
4JJRE-040-120-S06		12	4	50	6	☑	
4JJRE-040-160-S06		16	4	55	6	☑	
4JJRE-040-200-S06		20	4	60	6	☑	
4JJRE-040-250-S06		25	4	65	6	☑	

Objednací číslo	D (mm)	L2 (mm)	L1 (mm)	L (mm)	d h5 (mm)	Standardní položka
4JJRE-040-300-S06	4	30	4	70	6	☑
4JJRE-040-400-S06		40	4	80	6	☑
4JJRE-040-450-S06		45	4	90	6	☑
4JJRE-040-500-S06		50	4	100	6	☑
4JJRE-040-600-S06		60	4	110	6	☑
4JJRE-045-120-S06	4,5	12	4,5	50	6	☑
4JJRE-045-160-S06		16	4,5	55	6	☑
4JJRE-045-200-S06		20	4,5	60	6	☑
4JJRE-045-250-S06		25	4,5	65	6	☑
4JJRE-045-300-S06		30	4,5	70	6	☑
4JJRE-045-400-S06	40	4,5	80	6	☑	
4JJRE-050-160-S06	5	16	5	60	6	☑
4JJRE-050-200-S06		20	5	60	6	☑
4JJRE-050-250-S06		25	5	65	6	☑
4JJRE-050-300-S06		30	5	70	6	☑
4JJRE-050-400-S06		40	5	80	6	☑
4JJRE-050-500-S06		50	5	100	6	☑
4JJRE-050-600-S06	60	5	110	6	☑	
4JJRE-060-200-S06	6	20	6	60	6	☑
4JJRE-060-300-S06		30	6	75	6	☑
4JJRE-060-400-S06		40	6	80	6	☑
4JJRE-060-500-S06		50	6	90	6	☑
4JJRE-060-600-S06	60	6	100	6	☑	
4JJRE-080-250-S08	8	25	12	65	8	☑
4JJRE-080-400-S08		40	12	100	8	☑
4JJRE-080-500-S08		50	12	110	8	☑
4JJRE-100-300-S10	10	30	15	70	10	☑
4JJRE-100-500-S10		50	15	100	10	☑
4JJRE-100-600-S10		60	15	120	10	☑
4JJRE-120-400-S12	12	40	18	80	12	☑
4JJRE-120-600-S12		60	18	110	12	☑
4JJRE-120-700-S12		70	18	130	12	☑

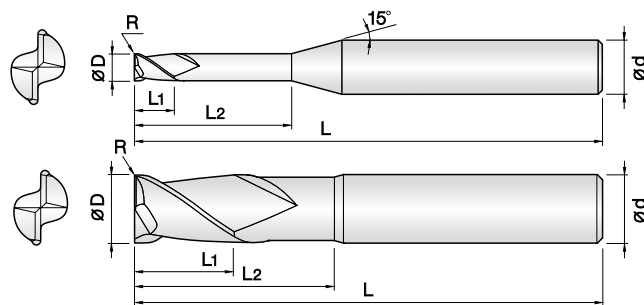

- **Určeno pro kalené oceli (52–68 HRC)**
- Vysoká odolnost proti opotřeby díky novému PVD povlaku s vysokým obsahem Si
- Velmi přesné tolerance rezných hran
- Široký sortiment rádií a vyložení pro optimální výběr nástroje
- Vynikající výkon při vysokých rezných rychlostech díky 0,2 μm tvrdkovu

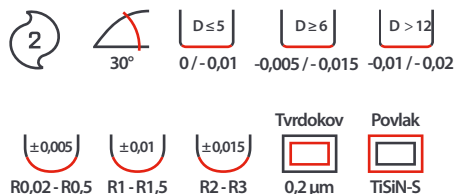

NOVINKA

Objednací číslo	D (mm)	R (mm)	L2 (mm)	L1 (mm)	L (mm)	d h5 (mm)	Standardní položka	
2JJCR-002-0002-005	0,2	R 0,02	0,5	0,2	40	4	☑	
2JJCR-002-0002-010			1	0,2	40	4	☑	
2JJCR-002-0002-015			1,5	0,2	40	4	☑	
2JJCR-002-0005-005		R 0,05	0,5	0,2	40	4	☑	
2JJCR-002-0005-010			1	0,2	40	4	☑	
2JJCR-002-0005-015			1,5	0,2	40	4	☑	
2JJCR-003-0002-010	0,3	R 0,02	1	0,3	40	4	☑	
2JJCR-003-0002-020			2	0,3	40	4	☑	
2JJCR-003-0002-030			3	0,3	40	4	☑	
2JJCR-003-0005-010		R 0,05	1	0,3	40	4	☑	
2JJCR-003-0005-020			2	0,3	40	4	☑	
2JJCR-003-0005-030			3	0,3	40	4	☑	
2JJCR-004-0002-010	0,4	R 0,02	1	0,4	40	4	☑	
2JJCR-004-0002-020			2	0,4	40	4	☑	
2JJCR-004-0002-030			3	0,4	40	4	☑	
2JJCR-004-0002-040			4	0,4	40	4	☑	
2JJCR-004-0005-010		R 0,05	1	0,4	40	4	☑	
2JJCR-004-0005-020			2	0,4	40	4	☑	
2JJCR-004-0005-030			3	0,4	40	4	☑	
2JJCR-004-0005-040			4	0,4	40	4	☑	
2JJCR-004-001-010		R 0,1	1	0,4	40	4	☑	
2JJCR-004-001-015			1,5	0,4	40	4	☑	
2JJCR-004-001-020			2	0,4	40	4	☑	
2JJCR-004-001-030			3	0,4	40	4	☑	
2JJCR-004-001-040	R 0,2	4	0,4	40	4	☑		
2JJCR-005-0002-010		0,5	R 0,02	1	0,5	45	4	☑
2JJCR-005-0002-015				1,5	0,5	45	4	☑
2JJCR-005-0002-020				2	0,5	45	4	☑
2JJCR-005-0002-025	2,5			0,5	45	4	☑	
2JJCR-005-0002-030	R 0,05		3	0,5	45	4	☑	
2JJCR-005-0002-040			4	0,5	45	4	☑	
2JJCR-005-0002-050			5	0,5	45	4	☑	
2JJCR-005-0002-060			6	0,5	45	4	☑	
2JJCR-005-0002-080	R 0,1		8	0,5	45	4	☑	
2JJCR-005-0002-100			10	0,5	45	4	☑	
2JJCR-005-0005-010			R 0,05	1	0,5	45	4	☑
2JJCR-005-0005-015				1,5	0,5	45	4	☑
2JJCR-005-0005-020	2	0,5		45	4	☑		
2JJCR-005-0005-020	2	0,5		45	4	☑		

Objednací číslo	D (mm)	R (mm)	L2 (mm)	L1 (mm)	L (mm)	d h5 (mm)	Standardní položka	
2JJCR-005-0005-025	0,5	R 0,05	2,5	0,5	45	4	☑	
2JJCR-005-0005-030			3	0,5	45	4	☑	
2JJCR-005-0005-040			4	0,5	45	4	☑	
2JJCR-005-0005-050			5	0,5	45	4	☑	
2JJCR-005-0005-060			6	0,5	45	4	☑	
2JJCR-005-0005-080			8	0,5	45	4	☑	
2JJCR-005-0005-100		R 0,1	10	0,5	45	4	☑	
2JJCR-005-001-010			1	0,5	45	4	☑	
2JJCR-005-001-015			1,5	0,5	45	4	☑	
2JJCR-005-001-020			2	0,5	45	4	☑	
2JJCR-005-001-025			2,5	0,5	45	4	☑	
2JJCR-005-001-030			3	0,5	45	4	☑	
2JJCR-005-001-040	R 0,2	4	0,5	45	4	☑		
2JJCR-005-001-050		5	0,5	45	4	☑		
2JJCR-005-001-060		6	0,5	45	4	☑		
2JJCR-005-001-080		8	0,5	45	4	☑		
2JJCR-005-001-100	0,6	R 0,02	10	0,5	45	4	☑	
2JJCR-006-0002-020			2	0,6	45	4	☑	
2JJCR-006-0002-030			3	0,6	45	4	☑	
2JJCR-006-0002-040			4	0,6	45	4	☑	
2JJCR-006-0002-060			6	0,6	45	4	☑	
2JJCR-006-0002-080			8	0,6	45	4	☑	
2JJCR-006-0002-100		R 0,05	10	0,6	45	4	☑	
2JJCR-006-0002-120			12	0,6	50	4	☑	
2JJCR-006-0005-020			R 0,1	2	0,6	45	4	☑
2JJCR-006-0005-030				3	0,6	45	4	☑
2JJCR-006-0005-040				4	0,6	45	4	☑
2JJCR-006-0005-060				6	0,6	45	4	☑
2JJCR-006-0005-080	8	0,6		45	4	☑		
2JJCR-006-0005-100	10	0,6		45	4	☑		
2JJCR-006-0005-120	R 0,1	12		0,6	50	4	☑	
2JJCR-006-001-020		2		0,6	45	4	☑	
2JJCR-006-001-030		3		0,6	45	4	☑	
2JJCR-006-001-040		4		0,6	45	4	☑	
2JJCR-006-001-060		6		0,6	45	4	☑	
2JJCR-006-001-080		8		0,6	45	4	☑	
2JJCR-006-001-100	R 0,1	10	0,6	45	4	☑		
2JJCR-006-001-120		12	0,6	50	4	☑		

NOVINKA

Objednací číslo	D (mm)	R (mm)	L2 (mm)	L1 (mm)	L (mm)	d h5 (mm)	Standardní položka		
2JJCR-007-001-020	0,7	R 0,1	2	0,7	45	4	<input checked="" type="checkbox"/>		
2JJCR-007-001-040			4	0,7	45	4	<input checked="" type="checkbox"/>		
2JJCR-007-001-060			6	0,7	45	4	<input checked="" type="checkbox"/>		
2JJCR-007-001-080			8	0,7	45	4	<input checked="" type="checkbox"/>		
2JJCR-007-001-100			10	0,7	45	4	<input checked="" type="checkbox"/>		
2JJCR-008-0002-020	0,8	R 0,02	2	0,8	45	4	<input checked="" type="checkbox"/>		
2JJCR-008-0002-040			4	0,8	45	4	<input checked="" type="checkbox"/>		
2JJCR-008-0002-060			6	0,8	45	4	<input checked="" type="checkbox"/>		
2JJCR-008-0002-080			8	0,8	45	4	<input checked="" type="checkbox"/>		
2JJCR-008-0002-100			10	0,8	45	4	<input checked="" type="checkbox"/>		
2JJCR-008-0002-120			12	0,8	50	4	<input checked="" type="checkbox"/>		
2JJCR-008-0005-020		0,8	R 0,05	2	0,8	45	4	<input checked="" type="checkbox"/>	
2JJCR-008-0005-040				4	0,8	45	4	<input checked="" type="checkbox"/>	
2JJCR-008-0005-060				6	0,8	45	4	<input checked="" type="checkbox"/>	
2JJCR-008-0005-080				8	0,8	45	4	<input checked="" type="checkbox"/>	
2JJCR-008-0005-100				10	0,8	45	4	<input checked="" type="checkbox"/>	
2JJCR-008-0005-120				12	0,8	50	4	<input checked="" type="checkbox"/>	
2JJCR-008-001-020	0,8		R 0,1	2	0,8	45	4	<input checked="" type="checkbox"/>	
2JJCR-008-001-040				4	0,8	45	4	<input checked="" type="checkbox"/>	
2JJCR-008-001-060				6	0,8	45	4	<input checked="" type="checkbox"/>	
2JJCR-008-001-080				8	0,8	45	4	<input checked="" type="checkbox"/>	
2JJCR-008-001-100				10	0,8	45	4	<input checked="" type="checkbox"/>	
2JJCR-008-001-120				12	0,8	50	4	<input checked="" type="checkbox"/>	
2JJCR-008-002-020		0,8	R 0,2	2	0,8	45	4	<input checked="" type="checkbox"/>	
2JJCR-008-002-040				4	0,8	45	4	<input checked="" type="checkbox"/>	
2JJCR-008-002-060				6	0,8	45	4	<input checked="" type="checkbox"/>	
2JJCR-008-002-080				8	0,8	45	4	<input checked="" type="checkbox"/>	
2JJCR-008-002-100				10	0,8	45	4	<input checked="" type="checkbox"/>	
2JJCR-008-002-120				12	0,8	50	4	<input checked="" type="checkbox"/>	
2JJCR-010-0002-040	1		R 0,02	4	1	45	4	<input checked="" type="checkbox"/>	
2JJCR-010-0002-060				6	1	45	4	<input checked="" type="checkbox"/>	
2JJCR-010-0002-080				8	1	45	4	<input checked="" type="checkbox"/>	
2JJCR-010-0002-100				10	1	50	4	<input checked="" type="checkbox"/>	
2JJCR-010-0002-120				12	1	50	4	<input checked="" type="checkbox"/>	
2JJCR-010-0002-140				14	1	50	4	<input checked="" type="checkbox"/>	
2JJCR-010-0002-160		16		1	50	4	<input checked="" type="checkbox"/>		
2JJCR-010-0002-200		20		1	50	4	<input checked="" type="checkbox"/>		
2JJCR-010-0005-040		1		R 0,05	4	1	45	4	<input checked="" type="checkbox"/>
2JJCR-010-0005-060					6	1	45	4	<input checked="" type="checkbox"/>
2JJCR-010-0005-080					8	1	45	4	<input checked="" type="checkbox"/>
2JJCR-010-0005-100					10	1	50	4	<input checked="" type="checkbox"/>
2JJCR-010-0005-120			12		1	50	4	<input checked="" type="checkbox"/>	
2JJCR-010-0005-140			14		1	50	4	<input checked="" type="checkbox"/>	
2JJCR-010-0005-160			16	1	50	4	<input checked="" type="checkbox"/>		
2JJCR-010-0005-200			20	1	50	4	<input checked="" type="checkbox"/>		
2JJCR-010-001-040			1	R 0,1	4	1	45	4	<input checked="" type="checkbox"/>
2JJCR-010-001-060					6	1	45	4	<input checked="" type="checkbox"/>
2JJCR-010-001-080					8	1	45	4	<input checked="" type="checkbox"/>
2JJCR-010-001-100					10	1	50	4	<input checked="" type="checkbox"/>
2JJCR-010-001-120		12			1	50	4	<input checked="" type="checkbox"/>	
2JJCR-010-001-140		14			1	50	4	<input checked="" type="checkbox"/>	
2JJCR-010-001-160		16		1	50	4	<input checked="" type="checkbox"/>		

Objednací číslo	D (mm)	R (mm)	L2 (mm)	L1 (mm)	L (mm)	d h5 (mm)	Standardní položka		
2JJCR-010-001-200	1	R 0,1	20	1	50	4	<input checked="" type="checkbox"/>		
2JJCR-010-002-040			4	1	45	4	<input checked="" type="checkbox"/>		
2JJCR-010-002-060			6	1	45	4	<input checked="" type="checkbox"/>		
2JJCR-010-002-080			8	1	45	4	<input checked="" type="checkbox"/>		
2JJCR-010-002-100			10	1	50	4	<input checked="" type="checkbox"/>		
2JJCR-010-002-120			12	1	50	4	<input checked="" type="checkbox"/>		
2JJCR-010-002-140		R 0,2	14	1	50	4	<input checked="" type="checkbox"/>		
2JJCR-010-002-160			16	1	50	4	<input checked="" type="checkbox"/>		
2JJCR-010-002-200			20	1	50	4	<input checked="" type="checkbox"/>		
2JJCR-010-003-040			1	R 0,3	4	1	45	4	<input checked="" type="checkbox"/>
2JJCR-010-003-060					6	1	45	4	<input checked="" type="checkbox"/>
2JJCR-010-003-080					8	1	45	4	<input checked="" type="checkbox"/>
2JJCR-010-003-100	10	1			50	4	<input checked="" type="checkbox"/>		
2JJCR-010-003-120	12	1			50	4	<input checked="" type="checkbox"/>		
2JJCR-010-003-140	14	1			50	4	<input checked="" type="checkbox"/>		
2JJCR-010-003-160	R 0,2	16		1	50	4	<input checked="" type="checkbox"/>		
2JJCR-010-003-200		20		1	50	4	<input checked="" type="checkbox"/>		
2JJCR-012-0002-040		1,2		R 0,02	4	1,2	45	4	<input checked="" type="checkbox"/>
2JJCR-012-0002-060					6	1,2	45	4	<input checked="" type="checkbox"/>
2JJCR-012-0002-080					8	1,2	45	4	<input checked="" type="checkbox"/>
2JJCR-012-0002-100					10	1,2	50	4	<input checked="" type="checkbox"/>
2JJCR-012-0002-120	12		1,2		50	4	<input checked="" type="checkbox"/>		
2JJCR-012-0002-140	14		1,2		50	4	<input checked="" type="checkbox"/>		
2JJCR-012-0002-160	R 0,05		16	1,2	50	4	<input checked="" type="checkbox"/>		
2JJCR-012-0002-200			20	1,2	50	4	<input checked="" type="checkbox"/>		
2JJCR-012-0005-040			1,2	R 0,1	4	1,2	45	4	<input checked="" type="checkbox"/>
2JJCR-012-0005-060					6	1,2	45	4	<input checked="" type="checkbox"/>
2JJCR-012-0005-080					8	1,2	45	4	<input checked="" type="checkbox"/>
2JJCR-012-0005-100					10	1,2	50	4	<input checked="" type="checkbox"/>
2JJCR-012-0005-120	12	1,2			50	4	<input checked="" type="checkbox"/>		
2JJCR-012-0005-140	14	1,2			50	4	<input checked="" type="checkbox"/>		
2JJCR-012-0005-160	R 0,2	16		1,2	50	4	<input checked="" type="checkbox"/>		
2JJCR-012-0005-200		20		1,2	50	4	<input checked="" type="checkbox"/>		
2JJCR-012-001-040		1,2		R 0,1	4	1,2	45	4	<input checked="" type="checkbox"/>
2JJCR-012-001-060					6	1,2	45	4	<input checked="" type="checkbox"/>
2JJCR-012-001-080					8	1,2	45	4	<input checked="" type="checkbox"/>
2JJCR-012-001-100					10	1,2	50	4	<input checked="" type="checkbox"/>
2JJCR-012-001-120	12		1,2		50	4	<input checked="" type="checkbox"/>		
2JJCR-012-001-140	14		1,2		50	4	<input checked="" type="checkbox"/>		
2JJCR-012-001-160	R 0,2		16	1,2	50	4	<input checked="" type="checkbox"/>		
2JJCR-012-001-200			20	1,2	50	4	<input checked="" type="checkbox"/>		
2JJCR-012-002-040			1,2	R 0,2	4	1,2	45	4	<input checked="" type="checkbox"/>
2JJCR-012-002-060					6	1,2	45	4	<input checked="" type="checkbox"/>
2JJCR-012-002-080					8	1,2	45	4	<input checked="" type="checkbox"/>
2JJCR-012-002-100					10	1,2	50	4	<input checked="" type="checkbox"/>
2JJCR-012-002-120	12	1,2			50	4	<input checked="" type="checkbox"/>		
2JJCR-012-002-140	14	1,2			50	4	<input checked="" type="checkbox"/>		
2JJCR-012-002-160	R 0,3	16		1,2	50	4	<input checked="" type="checkbox"/>		
2JJCR-012-002-200		20		1,2	50	4	<input checked="" type="checkbox"/>		
2JJCR-012-003-040		R 0,3		4	1,2	45	4	<input checked="" type="checkbox"/>	
2JJCR-012-003-060				6	1,2	45	4	<input checked="" type="checkbox"/>	
2JJCR-012-003-080				8	1,2	45	4	<input checked="" type="checkbox"/>	
2JJCR-012-003-080				8	1,2	45	4	<input checked="" type="checkbox"/>	

NOVINKA

Objednací číslo	D (mm)	R (mm)	L2 (mm)	L1 (mm)	L (mm)	d h5 (mm)	Standardní položka		
2JJCR-012-003-100	1,2	R 0,3	10	1,2	50	4	<input checked="" type="checkbox"/>		
2JJCR-012-003-120			12	1,2	50	4	<input checked="" type="checkbox"/>		
2JJCR-012-003-140			14	1,2	50	4	<input checked="" type="checkbox"/>		
2JJCR-012-003-160			16	1,2	50	4	<input checked="" type="checkbox"/>		
2JJCR-012-003-200			20	1,2	50	4	<input checked="" type="checkbox"/>		
2JJCR-015-0002-040	1,5	R 0,02	4	1,5	45	4	<input checked="" type="checkbox"/>		
2JJCR-015-0002-060			6	1,5	45	4	<input checked="" type="checkbox"/>		
2JJCR-015-0002-080			8	1,5	45	4	<input checked="" type="checkbox"/>		
2JJCR-015-0002-100			10	1,5	50	4	<input checked="" type="checkbox"/>		
2JJCR-015-0002-120			12	1,5	50	4	<input checked="" type="checkbox"/>		
2JJCR-015-0002-140			14	1,5	50	4	<input checked="" type="checkbox"/>		
2JJCR-015-0002-160		R 0,05	R 0,05	16	1,5	50	4	<input checked="" type="checkbox"/>	
2JJCR-015-0002-200				20	1,5	50	4	<input checked="" type="checkbox"/>	
2JJCR-015-0005-040				4	1,5	45	4	<input checked="" type="checkbox"/>	
2JJCR-015-0005-060				6	1,5	45	4	<input checked="" type="checkbox"/>	
2JJCR-015-0005-080				8	1,5	45	4	<input checked="" type="checkbox"/>	
2JJCR-015-0005-100				10	1,5	50	4	<input checked="" type="checkbox"/>	
2JJCR-015-0005-120				12	1,5	50	4	<input checked="" type="checkbox"/>	
2JJCR-015-0005-140				14	1,5	50	4	<input checked="" type="checkbox"/>	
2JJCR-015-0005-160				16	1,5	50	4	<input checked="" type="checkbox"/>	
2JJCR-015-0005-200				20	1,5	50	4	<input checked="" type="checkbox"/>	
2JJCR-015-001-040	R 0,1	R 0,1	4	1,5	45	4	<input checked="" type="checkbox"/>		
2JJCR-015-001-060			6	1,5	45	4	<input checked="" type="checkbox"/>		
2JJCR-015-001-080			8	1,5	45	4	<input checked="" type="checkbox"/>		
2JJCR-015-001-100			10	1,5	50	4	<input checked="" type="checkbox"/>		
2JJCR-015-001-120			12	1,5	50	4	<input checked="" type="checkbox"/>		
2JJCR-015-001-140			14	1,5	50	4	<input checked="" type="checkbox"/>		
2JJCR-015-001-160			16	1,5	50	4	<input checked="" type="checkbox"/>		
2JJCR-015-001-200			20	1,5	50	4	<input checked="" type="checkbox"/>		
2JJCR-015-002-040			R 0,2	R 0,2	4	1,5	45	4	<input checked="" type="checkbox"/>
2JJCR-015-002-060					6	1,5	45	4	<input checked="" type="checkbox"/>
2JJCR-015-002-080	8	1,5			45	4	<input checked="" type="checkbox"/>		
2JJCR-015-002-100	10	1,5			50	4	<input checked="" type="checkbox"/>		
2JJCR-015-002-120	12	1,5			50	4	<input checked="" type="checkbox"/>		
2JJCR-015-002-140	14	1,5			50	4	<input checked="" type="checkbox"/>		
2JJCR-015-002-160	16	1,5			50	4	<input checked="" type="checkbox"/>		
2JJCR-015-002-200	20	1,5			50	4	<input checked="" type="checkbox"/>		
2JJCR-015-003-040	R 0,3	R 0,3			4	1,5	45	4	<input checked="" type="checkbox"/>
2JJCR-015-003-060					6	1,5	45	4	<input checked="" type="checkbox"/>
2JJCR-015-003-080			8	1,5	45	4	<input checked="" type="checkbox"/>		
2JJCR-015-003-100			10	1,5	50	4	<input checked="" type="checkbox"/>		
2JJCR-015-003-120			12	1,5	50	4	<input checked="" type="checkbox"/>		
2JJCR-015-003-140			14	1,5	50	4	<input checked="" type="checkbox"/>		
2JJCR-015-003-160			16	1,5	50	4	<input checked="" type="checkbox"/>		
2JJCR-015-003-200			20	1,5	50	4	<input checked="" type="checkbox"/>		
2JJCR-015-005-040	R 0,5	R 0,5	4	1,5	45	4	<input checked="" type="checkbox"/>		
2JJCR-015-005-060			6	1,5	45	4	<input checked="" type="checkbox"/>		
2JJCR-015-005-080			8	1,5	45	4	<input checked="" type="checkbox"/>		
2JJCR-015-005-100			10	1,5	50	4	<input checked="" type="checkbox"/>		
2JJCR-015-005-120			12	1,5	50	4	<input checked="" type="checkbox"/>		
2JJCR-015-005-140			14	1,5	50	4	<input checked="" type="checkbox"/>		
2JJCR-015-005-160			16	1,5	50	4	<input checked="" type="checkbox"/>		

Objednací číslo	D (mm)	R (mm)	L2 (mm)	L1 (mm)	L (mm)	d h5 (mm)	Standardní položka		
2JJCR-015-005-200	1,5	R 0,5	20	1,5	50	4	<input checked="" type="checkbox"/>		
2JJCR-020-0002-060	2	R 0,02	6	2	45	4	<input checked="" type="checkbox"/>		
2JJCR-020-0002-080			8	2	45	4	<input checked="" type="checkbox"/>		
2JJCR-020-0002-100			10	2	50	4	<input checked="" type="checkbox"/>		
2JJCR-020-0002-120			12	2	50	4	<input checked="" type="checkbox"/>		
2JJCR-020-0002-140			14	2	50	4	<input checked="" type="checkbox"/>		
2JJCR-020-0002-160			16	2	50	4	<input checked="" type="checkbox"/>		
2JJCR-020-0002-200			20	2	50	4	<input checked="" type="checkbox"/>		
2JJCR-020-0002-250			25	2	60	4	<input checked="" type="checkbox"/>		
2JJCR-020-0005-060		R 0,05	R 0,05	6	2	45	4	<input checked="" type="checkbox"/>	
2JJCR-020-0005-080				8	2	45	4	<input checked="" type="checkbox"/>	
2JJCR-020-0005-100				10	2	50	4	<input checked="" type="checkbox"/>	
2JJCR-020-0005-120				12	2	50	4	<input checked="" type="checkbox"/>	
2JJCR-020-0005-140				14	2	50	4	<input checked="" type="checkbox"/>	
2JJCR-020-0005-160				16	2	50	4	<input checked="" type="checkbox"/>	
2JJCR-020-0005-200				20	2	50	4	<input checked="" type="checkbox"/>	
2JJCR-020-0005-250				25	2	60	4	<input checked="" type="checkbox"/>	
2JJCR-020-001-060	R 0,1			R 0,1	6	2	45	4	<input checked="" type="checkbox"/>
2JJCR-020-001-080					8	2	45	4	<input checked="" type="checkbox"/>
2JJCR-020-001-100		10	2		50	4	<input checked="" type="checkbox"/>		
2JJCR-020-001-120		12	2		50	4	<input checked="" type="checkbox"/>		
2JJCR-020-001-140		14	2		50	4	<input checked="" type="checkbox"/>		
2JJCR-020-001-160		16	2		50	4	<input checked="" type="checkbox"/>		
2JJCR-020-001-200		20	2		50	4	<input checked="" type="checkbox"/>		
2JJCR-020-001-250		25	2		60	4	<input checked="" type="checkbox"/>		
2JJCR-020-002-060	R 0,2	R 0,2	6	2	45	4	<input checked="" type="checkbox"/>		
2JJCR-020-002-080			8	2	45	4	<input checked="" type="checkbox"/>		
2JJCR-020-002-100			10	2	50	4	<input checked="" type="checkbox"/>		
2JJCR-020-002-120			12	2	50	4	<input checked="" type="checkbox"/>		
2JJCR-020-002-140			14	2	50	4	<input checked="" type="checkbox"/>		
2JJCR-020-002-160			16	2	50	4	<input checked="" type="checkbox"/>		
2JJCR-020-002-200			20	2	50	4	<input checked="" type="checkbox"/>		
2JJCR-020-002-250			25	2	60	4	<input checked="" type="checkbox"/>		
2JJCR-020-002-300			30	2	70	4	<input checked="" type="checkbox"/>		
2JJCR-020-003-060			R 0,3	R 0,3	6	2	45	4	<input checked="" type="checkbox"/>
2JJCR-020-003-080	8	2			45	4	<input checked="" type="checkbox"/>		
2JJCR-020-003-100	10	2			50	4	<input checked="" type="checkbox"/>		
2JJCR-020-003-120	12	2			50	4	<input checked="" type="checkbox"/>		
2JJCR-020-003-140	14	2			50	4	<input checked="" type="checkbox"/>		
2JJCR-020-003-160	16	2			50	4	<input checked="" type="checkbox"/>		
2JJCR-020-003-200	20	2			50	4	<input checked="" type="checkbox"/>		
2JJCR-020-003-250	25	2			60	4	<input checked="" type="checkbox"/>		
2JJCR-020-003-300	30	2	70	4	<input checked="" type="checkbox"/>				
2JJCR-020-005-060	R 0,5	R 0,5	6	2	45	4	<input checked="" type="checkbox"/>		
2JJCR-020-005-080			8	2	45	4	<input checked="" type="checkbox"/>		
2JJCR-020-005-100			10	2	50	4	<input checked="" type="checkbox"/>		
2JJCR-020-005-120			12	2	50	4	<input checked="" type="checkbox"/>		
2JJCR-020-005-140			14	2	50	4	<input checked="" type="checkbox"/>		
2JJCR-020-005-160			16	2	50	4	<input checked="" type="checkbox"/>		
2JJCR-020-005-200			20	2	50	4	<input checked="" type="checkbox"/>		
2JJCR-020-005-250	25	2	60	4	<input checked="" type="checkbox"/>				

Objednací číslo	D (mm)	R (mm)	L2 (mm)	L1 (mm)	L (mm)	d h5 (mm)	Standardní položka	
2JJCR-020-005-300	2	R 0,5	30	2	70	4	<input checked="" type="checkbox"/>	
2JJCR-025-001-100			R 0,1	10	2,5	50	4	<input checked="" type="checkbox"/>
2JJCR-025-001-160				16	2,5	50	4	<input checked="" type="checkbox"/>
2JJCR-025-001-200				20	2,5	50	4	<input checked="" type="checkbox"/>
2JJCR-025-001-250				25	2,5	60	4	<input checked="" type="checkbox"/>
2JJCR-025-001-300		30		2,5	70	4	<input checked="" type="checkbox"/>	
2JJCR-025-002-100		2,5	R 0,2	10	2,5	50	4	<input checked="" type="checkbox"/>
2JJCR-025-002-160				16	2,5	50	4	<input checked="" type="checkbox"/>
2JJCR-025-002-200				20	2,5	50	4	<input checked="" type="checkbox"/>
2JJCR-025-003-100			R 0,3	10	2,5	50	4	<input checked="" type="checkbox"/>
2JJCR-025-003-160				16	2,5	50	4	<input checked="" type="checkbox"/>
2JJCR-025-003-200				20	2,5	50	4	<input checked="" type="checkbox"/>
2JJCR-025-005-100				R 0,5	10	2,5	50	4
2JJCR-025-005-160			16		2,5	50	4	<input checked="" type="checkbox"/>
2JJCR-025-005-200			20		2,5	50	4	<input checked="" type="checkbox"/>
2JJCR-030-001-100			3		R 0,1	10	3	50
2JJCR-030-001-120		12		3		50	6	<input checked="" type="checkbox"/>
2JJCR-030-001-160		16		3		55	6	<input checked="" type="checkbox"/>
2JJCR-030-001-200		20		3		60	6	<input checked="" type="checkbox"/>
2JJCR-030-001-250		25		3		65	6	<input checked="" type="checkbox"/>
2JJCR-030-001-300	30	3		70		6	<input checked="" type="checkbox"/>	
2JJCR-030-001-350	35	3		75		6	<input checked="" type="checkbox"/>	
2JJCR-030-001-400	40	3		80		6	<input checked="" type="checkbox"/>	
2JJCR-030-002-100	R 0,2	10		3		50	6	<input checked="" type="checkbox"/>
2JJCR-030-002-120		12		3		50	6	<input checked="" type="checkbox"/>
2JJCR-030-002-160		16		3	55	6	<input checked="" type="checkbox"/>	
2JJCR-030-002-200		20		3	60	6	<input checked="" type="checkbox"/>	
2JJCR-030-002-250		25		3	65	6	<input checked="" type="checkbox"/>	
2JJCR-030-002-300		30		3	70	6	<input checked="" type="checkbox"/>	
2JJCR-030-002-350		35		3	75	6	<input checked="" type="checkbox"/>	
2JJCR-030-002-400		40		3	80	6	<input checked="" type="checkbox"/>	
2JJCR-030-003-100		R 0,3		10	3	50	6	<input checked="" type="checkbox"/>
2JJCR-030-003-120				12	3	50	6	<input checked="" type="checkbox"/>
2JJCR-030-003-160	16			3	55	6	<input checked="" type="checkbox"/>	
2JJCR-030-003-200	20			3	60	6	<input checked="" type="checkbox"/>	
2JJCR-030-003-250	25			3	65	6	<input checked="" type="checkbox"/>	
2JJCR-030-003-300	30			3	70	6	<input checked="" type="checkbox"/>	
2JJCR-030-003-350	35			3	75	6	<input checked="" type="checkbox"/>	
2JJCR-030-003-400	40			3	80	6	<input checked="" type="checkbox"/>	
2JJCR-030-005-100	R 0,5			10	3	50	6	<input checked="" type="checkbox"/>
2JJCR-030-005-120				12	3	50	6	<input checked="" type="checkbox"/>
2JJCR-030-005-160		16		3	55	6	<input checked="" type="checkbox"/>	
2JJCR-030-005-200		20		3	60	6	<input checked="" type="checkbox"/>	
2JJCR-030-005-250		25		3	65	6	<input checked="" type="checkbox"/>	
2JJCR-030-005-300		30		3	70	6	<input checked="" type="checkbox"/>	
2JJCR-030-005-350		35	3	75	6	<input checked="" type="checkbox"/>		
2JJCR-030-005-400		40	3	80	6	<input checked="" type="checkbox"/>		
2JJCR-030-010-100		R 1	10	3	50	6	<input checked="" type="checkbox"/>	
2JJCR-030-010-120			12	3	50	6	<input checked="" type="checkbox"/>	
2JJCR-030-010-160	16		3	55	6	<input checked="" type="checkbox"/>		
2JJCR-030-010-200	20		3	60	6	<input checked="" type="checkbox"/>		
2JJCR-030-010-250	25		3	65	6	<input checked="" type="checkbox"/>		

Objednací číslo	D (mm)	R (mm)	L2 (mm)	L1 (mm)	L (mm)	d h5 (mm)	Standardní položka	
2JJCR-030-010-300	3	R 1	30	3	70	6	<input checked="" type="checkbox"/>	
2JJCR-030-010-350			35	3	75	6	<input checked="" type="checkbox"/>	
2JJCR-030-010-400			40	3	80	6	<input checked="" type="checkbox"/>	
2JJCR-040-001-120			R 0,1	12	4	50	6	<input checked="" type="checkbox"/>
2JJCR-040-001-160				16	4	55	6	<input checked="" type="checkbox"/>
2JJCR-040-001-200		20		4	60	6	<input checked="" type="checkbox"/>	
2JJCR-040-001-250		25		4	65	6	<input checked="" type="checkbox"/>	
2JJCR-040-001-300		30		4	70	6	<input checked="" type="checkbox"/>	
2JJCR-040-001-350		35		4	75	6	<input checked="" type="checkbox"/>	
2JJCR-040-001-400		40		4	80	6	<input checked="" type="checkbox"/>	
2JJCR-040-002-120	R 0,2	12		4	50	6	<input checked="" type="checkbox"/>	
2JJCR-040-002-160		16		4	55	6	<input checked="" type="checkbox"/>	
2JJCR-040-002-200		20		4	60	6	<input checked="" type="checkbox"/>	
2JJCR-040-002-250		25	4	65	6	<input checked="" type="checkbox"/>		
2JJCR-040-002-300		30	4	70	6	<input checked="" type="checkbox"/>		
2JJCR-040-002-350		35	4	75	6	<input checked="" type="checkbox"/>		
2JJCR-040-002-400		40	4	80	6	<input checked="" type="checkbox"/>		
2JJCR-040-003-120		R 0,3	12	4	50	6	<input checked="" type="checkbox"/>	
2JJCR-040-003-160			16	4	55	6	<input checked="" type="checkbox"/>	
2JJCR-040-003-200			20	4	60	6	<input checked="" type="checkbox"/>	
2JJCR-040-003-250	25		4	65	6	<input checked="" type="checkbox"/>		
2JJCR-040-003-300	30		4	70	6	<input checked="" type="checkbox"/>		
2JJCR-040-003-350	35		4	75	6	<input checked="" type="checkbox"/>		
2JJCR-040-003-400	40		4	80	6	<input checked="" type="checkbox"/>		
2JJCR-040-005-120	R 0,5		12	4	50	6	<input checked="" type="checkbox"/>	
2JJCR-040-005-160			16	4	55	6	<input checked="" type="checkbox"/>	
2JJCR-040-005-200			20	4	60	6	<input checked="" type="checkbox"/>	
2JJCR-040-005-250		25	4	65	6	<input checked="" type="checkbox"/>		
2JJCR-040-005-300		30	4	70	6	<input checked="" type="checkbox"/>		
2JJCR-040-005-350		35	4	75	6	<input checked="" type="checkbox"/>		
2JJCR-040-005-400		40	4	80	6	<input checked="" type="checkbox"/>		
2JJCR-040-010-120		R 1	12	4	50	6	<input checked="" type="checkbox"/>	
2JJCR-040-010-160			16	4	55	6	<input checked="" type="checkbox"/>	
2JJCR-040-010-200			20	4	60	6	<input checked="" type="checkbox"/>	
2JJCR-040-010-250	25		4	65	6	<input checked="" type="checkbox"/>		
2JJCR-040-010-300	30		4	70	6	<input checked="" type="checkbox"/>		
2JJCR-040-010-350	35		4	75	6	<input checked="" type="checkbox"/>		
2JJCR-040-010-400	40		4	80	6	<input checked="" type="checkbox"/>		
2JJCR-050-002-150	5		R 0,2	15	6	60	6	<input checked="" type="checkbox"/>
2JJCR-050-002-250				25	6	70	6	<input checked="" type="checkbox"/>
2JJCR-050-002-300				30	6	70	6	<input checked="" type="checkbox"/>
2JJCR-050-002-400		40		6	80	6	<input checked="" type="checkbox"/>	
2JJCR-050-005-150		R 0,5		15	6	60	6	<input checked="" type="checkbox"/>
2JJCR-050-005-250			25	6	70	6	<input checked="" type="checkbox"/>	
2JJCR-050-005-300			30	6	70	6	<input checked="" type="checkbox"/>	
2JJCR-050-005-400			40	6	80	6	<input checked="" type="checkbox"/>	
2JJCR-050-010-150			R 1	15	6	60	6	<input checked="" type="checkbox"/>
2JJCR-050-010-250		25		6	70	6	<input checked="" type="checkbox"/>	
2JJCR-050-010-300	30	6		70	6	<input checked="" type="checkbox"/>		
2JJCR-050-010-400	40	6		80	6	<input checked="" type="checkbox"/>		
2JJCR-060-001-200	6	R 0,1		20	7	60	6	<input checked="" type="checkbox"/>
2JJCR-060-001-400			40	7	80	6	<input checked="" type="checkbox"/>	

Objednací číslo	D (mm)	R (mm)	L2 (mm)	L1 (mm)	L (mm)	d h5 (mm)	Standardní položka	
2JJCR-060-002-200	6	R 0,2	20	7	60	6	<input checked="" type="checkbox"/>	
2JJCR-060-002-400			40	7	80	6	<input checked="" type="checkbox"/>	
2JJCR-060-003-200		R 0,3	20	7	60	6	<input checked="" type="checkbox"/>	
2JJCR-060-003-400			40	7	80	6	<input checked="" type="checkbox"/>	
2JJCR-060-005-200		R 0,5	20	7	60	6	<input checked="" type="checkbox"/>	
2JJCR-060-005-400			40	7	80	6	<input checked="" type="checkbox"/>	
2JJCR-060-010-200		R 1	20	7	60	6	<input checked="" type="checkbox"/>	
2JJCR-060-010-400			40	7	80	6	<input checked="" type="checkbox"/>	
2JJCR-060-015-200		R 1,5	20	7	60	6	<input checked="" type="checkbox"/>	
2JJCR-060-015-400			40	7	80	6	<input checked="" type="checkbox"/>	
2JJCR-080-002-220		8	R 0,2	22	9	65	8	<input checked="" type="checkbox"/>
2JJCR-080-003-220			R 0,3	22	9	65	8	<input checked="" type="checkbox"/>
2JJCR-080-005-220	R 0,5		22	9	65	8	<input checked="" type="checkbox"/>	
2JJCR-080-010-220	R 1		22	9	65	8	<input checked="" type="checkbox"/>	
2JJCR-080-015-220	R 1,5		22	9	65	8	<input checked="" type="checkbox"/>	
2JJCR-100-002-240	10	R 0,2	24	11	70	10	<input checked="" type="checkbox"/>	
2JJCR-100-003-240		R 0,3	24	11	70	10	<input checked="" type="checkbox"/>	
2JJCR-100-005-240		R 0,5	24	11	70	10	<input checked="" type="checkbox"/>	
2JJCR-100-010-240		R 1	24	11	70	10	<input checked="" type="checkbox"/>	
2JJCR-100-015-240		R 1,5	24	11	70	10	<input checked="" type="checkbox"/>	
2JJCR-100-020-240		R 2	24	11	70	10	<input checked="" type="checkbox"/>	
2JJCR-120-002-260	12	R 0,2	26	13	80	12	<input checked="" type="checkbox"/>	
2JJCR-120-003-260		R 0,3	26	13	80	12	<input checked="" type="checkbox"/>	
2JJCR-120-005-260		R 0,5	26	13	80	12	<input checked="" type="checkbox"/>	
2JJCR-120-010-260		R 1	26	13	80	12	<input checked="" type="checkbox"/>	
2JJCR-120-015-260		R 1,5	26	13	80	12	<input checked="" type="checkbox"/>	
2JJCR-120-020-260		R 2	26	13	80	12	<input checked="" type="checkbox"/>	
2JJCR-120-030-260		R 3	26	13	80	12	<input checked="" type="checkbox"/>	
2JJCR-160-005-110	16	R 0,5	35	20	110	16	<input checked="" type="checkbox"/>	
2JJCR-160-010-110		R 1	35	20	110	16	<input checked="" type="checkbox"/>	

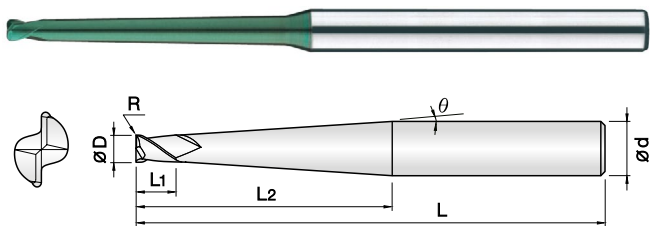

- Určeno pro kalené oceli (52–68 HRC)
- Vysoká odolnost proti opotřebování díky PVD povlaku na bázi Si
- Velmi přesné tolerance rezných hran
- Široký sortiment rádiusů a vyložení pro optimální výběr nástroje
- Vysoká tuhost díky kuželovému odlehčení
- Vynikající výkon při vysokých rezných rychlostech díky 0,2 μm tvrdokovu

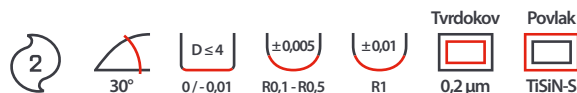

Objednáací číslo	D (mm)	R (mm)	Úhel θ	L2 (mm)	L1 (mm)	L (mm)	d h5 (mm)	Standardní položka	
2JJTC-010-001-0601	1	R 0,1	1°	6	1	50	4	☑	
2JJTC-010-001-1001			1°	10	1	50	4	☑	
2JJTC-010-001-1501			1°	15	1	50	4	☑	
2JJTC-010-001-2001			1°	20	1	60	4	☑	
2JJTC-010-001-2501			1°	25	1	60	4	☑	
2JJTC-010-001-3001			1°	30	1	70	4	☑	
2JJTC-010-001-3501			1°	35	1	75	4	☑	
2JJTC-010-002-0601			1°	6	1	50	4	☑	
2JJTC-010-002-1001			1°	10	1	50	4	☑	
2JJTC-010-002-1501			1°	15	1	50	4	☑	
2JJTC-010-002-2001			1°	20	1	60	4	☑	
2JJTC-010-002-2501			1°	25	1	60	4	☑	
2JJTC-010-002-3001			1°	30	1	70	4	☑	
2JJTC-010-002-3501			1°	35	1	75	4	☑	
2JJTC-010-003-0601		1°	6	1	50	4	☑		
2JJTC-010-003-1001		1°	10	1	50	4	☑		
2JJTC-010-003-1501		1°	15	1	50	4	☑		
2JJTC-010-003-2001		1°	20	1	60	4	☑		
2JJTC-010-003-2501		1°	25	1	60	4	☑		
2JJTC-010-003-3001		1°	30	1	70	4	☑		
2JJTC-010-003-3501		1°	35	1	75	4	☑		
2JJTC-015-002-1001		1,5	R 0,2	1°	10	1,5	50	4	☑
2JJTC-015-002-1501				1°	15	1,5	50	4	☑
2JJTC-015-002-2001				1°	20	1,5	60	4	☑
2JJTC-015-002-2501				1°	25	1,5	60	4	☑
2JJTC-015-002-3001				1°	30	1,5	70	4	☑
2JJTC-015-002-3501				1°	35	1,5	75	4	☑
2JJTC-015-003-1001				R 0,3	1°	10	1,5	50	4
2JJTC-015-003-1501	1°				15	1,5	50	4	☑
2JJTC-015-003-2001	1°				20	1,5	60	4	☑
2JJTC-015-003-2501	1°				25	1,5	60	4	☑
2JJTC-015-003-3001	1°		30		1,5	70	4	☑	
2JJTC-015-003-3501	1°		35		1,5	75	4	☑	
2JJTC-015-005-1001	R 0,5		1°		10	1,5	50	4	☑
2JJTC-015-005-1501			1°		15	1,5	50	4	☑
2JJTC-015-005-2001			1°		20	1,5	60	4	☑
2JJTC-015-005-2501			1°		25	1,5	60	4	☑
2JJTC-015-005-3001			1°	30	1,5	70	4	☑	
2JJTC-015-005-3001			1°	30	1,5	70	4	☑	

Objednáací číslo	D (mm)	R (mm)	Úhel θ	L2 (mm)	L1 (mm)	L (mm)	d h5 (mm)	Standardní položka	
2JJTC-015-005-3501	1,5	R 0,5	1°	35	1,5	75	4	☑	
2JJTC-020-002-1201	2	R 0,2	1°	12	2	50	4	☑	
2JJTC-020-002-1601			1°	16	2	50	4	☑	
2JJTC-020-002-2001			1°	20	2	60	4	☑	
2JJTC-020-002-2501			1°	25	2	60	4	☑	
2JJTC-020-002-3001			1°	30	2	70	4	☑	
2JJTC-020-002-3501			1°	35	2	75	4	☑	
2JJTC-020-002-4001			1°	40	2	80	4	☑	
2JJTC-020-002-5001			1°	50	2	90	4	☑	
2JJTC-020-003-1201			R 0,3	1°	12	2	50	4	☑
2JJTC-020-003-1601				1°	16	2	50	4	☑
2JJTC-020-003-2001		1°		20	2	60	4	☑	
2JJTC-020-003-2501		1°		25	2	60	4	☑	
2JJTC-020-003-3001		1°		30	2	70	4	☑	
2JJTC-020-003-3501		1°		35	2	75	4	☑	
2JJTC-020-003-4001		1°		40	2	80	4	☑	
2JJTC-020-003-5001		1°		50	2	90	4	☑	
2JJTC-020-005-1201		R 0,5		1°	12	2	50	4	☑
2JJTC-020-005-1601				1°	16	2	50	4	☑
2JJTC-020-005-2001			1°	20	2	60	4	☑	
2JJTC-020-005-2501			1°	25	2	60	4	☑	
2JJTC-020-005-3001	1°		30	2	70	4	☑		
2JJTC-020-005-3501	1°		35	2	75	4	☑		
2JJTC-020-005-4001	1°		40	2	80	4	☑		
2JJTC-020-005-5001	1°		50	2	90	4	☑		
2JJTC-030-002-2001	3		R 0,2	1°	20	3	60	6	☑
2JJTC-030-002-3001				1°	30	3	70	6	☑
2JJTC-030-002-4001		1°		40	3	80	6	☑	
2JJTC-030-002-5001		1°		50	3	90	6	☑	
2JJTC-030-002-6001		1°		60	3	100	6	☑	
2JJTC-030-003-2001		R 0,3	1°	20	3	60	6	☑	
2JJTC-030-003-3001			1°	30	3	70	6	☑	
2JJTC-030-003-4001			1°	40	3	80	6	☑	
2JJTC-030-003-5001			1°	50	3	90	6	☑	
2JJTC-030-003-6001			1°	60	3	100	6	☑	
2JJTC-030-005-2001			R 0,5	1°	20	3	60	6	☑
2JJTC-030-005-3001				1°	30	3	70	6	☑
2JJTC-030-005-4001				1°	40	3	80	6	☑



Objednací číslo	D (mm)	R (mm)	Úhel θ	L2 (mm)	L1 (mm)	L (mm)	d h5 (mm)	Standardní položka
2JJTC-030-005-5001	3	R 0,5	1°	50	3	90	6	<input checked="" type="checkbox"/>
2JJTC-030-005-6001			1°	60	3	100	6	<input checked="" type="checkbox"/>
2JJTC-030-010-2001		R 0,1	1°	20	3	60	6	<input checked="" type="checkbox"/>
2JJTC-030-010-3001			1°	30	3	70	6	<input checked="" type="checkbox"/>
2JJTC-030-010-4001			1°	40	3	80	6	<input checked="" type="checkbox"/>
2JJTC-030-010-5001			1°	50	3	90	6	<input checked="" type="checkbox"/>
2JJTC-030-010-6001			1°	60	3	100	6	<input checked="" type="checkbox"/>
2JJTC-040-002-2001			4	R 0,2	1	20	4	60
2JJTC-040-002-3001	1	30			4	70	6	<input checked="" type="checkbox"/>
2JJTC-040-002-4001	1	40			4	80	6	<input checked="" type="checkbox"/>
2JJTC-040-002-5001	1	50			4	90	6	<input checked="" type="checkbox"/>
2JJTC-040-002-6001	1	60			4	100	6	<input checked="" type="checkbox"/>
2JJTC-040-003-2001	R 0,3	1			20	4	60	6
2JJTC-040-003-3001		1		30	4	70	6	<input checked="" type="checkbox"/>
2JJTC-040-003-4001		1		40	4	80	6	<input checked="" type="checkbox"/>
2JJTC-040-003-5001		1		50	4	90	6	<input checked="" type="checkbox"/>
2JJTC-040-003-6001		1		60	4	100	6	<input checked="" type="checkbox"/>
2JJTC-040-005-2001		R 0,5		1	20	4	60	6
2JJTC-040-005-3001	1			30	4	70	6	<input checked="" type="checkbox"/>
2JJTC-040-005-4001	1			40	4	80	6	<input checked="" type="checkbox"/>
2JJTC-040-005-5001	1			50	4	90	6	<input checked="" type="checkbox"/>
2JJTC-040-005-6001	1			60	4	100	6	<input checked="" type="checkbox"/>
2JJTC-040-010-2001	R 1			1	20	4	60	6
2JJTC-040-010-3001		1		30	4	70	6	<input checked="" type="checkbox"/>
2JJTC-040-010-4001		1		40	4	80	6	<input checked="" type="checkbox"/>
2JJTC-040-010-5001		1		50	4	90	6	<input checked="" type="checkbox"/>
2JJTC-040-010-6001		1		60	4	100	6	<input checked="" type="checkbox"/>

JJ

HS

G

SNS

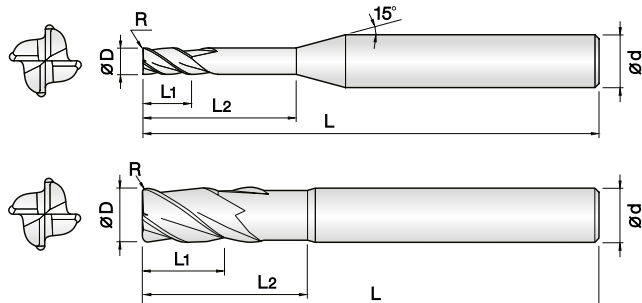

- Určeno pro kalené oceli (52–68 HRC)
- Vysoká odolnost proti opotřeбенí díky novému PVD povlaku s vysokým obsahem Si
- Velmi přesné tolerance rezných hran
- Široký sortiment rádiusů a vyložení pro optimální výběr nástroje
- Vynikající výkon při vysokých rezných rychlostech díky 0,2 μm tvrdkovu

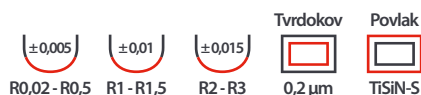

NOVINKA

Objednací číslo	D (mm)	R (mm)	L2 (mm)	L1 (mm)	L (mm)	d h5 (mm)	Standardní položka	
4JJCR-005-0005-020	0,5	R 0,05	2	0,5	45	4	☑	
4JJCR-005-0005-040			4	0,5	45	4	☑	
4JJCR-005-0005-060			6	0,5	45	4	☑	
4JJCR-005-0005-080			8	0,5	45	4	☑	
4JJCR-005-001-020		R 0,1	2	0,5	45	4	☑	
4JJCR-005-001-040			4	0,5	45	4	☑	
4JJCR-005-001-060			6	0,5	45	4	☑	
4JJCR-005-001-080			8	0,5	45	4	☑	
4JJCR-006-0005-020		0,6	R 0,05	2	0,6	45	4	☑
4JJCR-006-0005-040				4	0,6	45	4	☑
4JJCR-006-0005-060				6	0,6	45	4	☑
4JJCR-006-0005-080				8	0,6	45	4	☑
4JJCR-006-001-020			R 0,1	2	0,6	45	4	☑
4JJCR-006-001-040				4	0,6	45	4	☑
4JJCR-006-001-060				6	0,6	45	4	☑
4JJCR-006-001-080				8	0,6	45	4	☑
4JJCR-007-0005-020	0,7	R 0,05	2	0,7	45	4	☑	
4JJCR-007-0005-040			4	0,7	45	4	☑	
4JJCR-007-0005-060			6	0,7	45	4	☑	
4JJCR-007-0005-080			8	0,7	45	4	☑	
4JJCR-007-001-020		R 0,1	2	0,7	45	4	☑	
4JJCR-007-001-040			4	0,7	45	4	☑	
4JJCR-007-001-060			6	0,7	45	4	☑	
4JJCR-007-001-080			8	0,7	45	4	☑	
4JJCR-008-0002-020	0,8	R 0,02	2	0,8	45	4	☑	
4JJCR-008-0002-040			4	0,8	45	4	☑	
4JJCR-008-0002-060			6	0,8	45	4	☑	
4JJCR-008-0002-080			8	0,8	45	4	☑	
4JJCR-008-0002-100			10	0,8	45	4	☑	
4JJCR-008-0002-120			12	0,8	50	4	☑	
4JJCR-008-0005-020			R 0,05	2	0,8	45	4	☑
4JJCR-008-0005-040				4	0,8	45	4	☑
4JJCR-008-0005-060		6		0,8	45	4	☑	
4JJCR-008-0005-080		8		0,8	45	4	☑	
4JJCR-008-0005-100		10		0,8	45	4	☑	
4JJCR-008-0005-120		12		0,8	50	4	☑	
4JJCR-008-001-020		R 0,1		2	0,8	45	4	☑
4JJCR-008-001-040				4	0,8	45	4	☑

Objednací číslo	D (mm)	R (mm)	L2 (mm)	L1 (mm)	L (mm)	d h5 (mm)	Standardní položka	
4JJCR-008-001-060	0,8	R 0,1	6	0,8	45	4	☑	
4JJCR-008-001-080			8	0,8	45	4	☑	
4JJCR-008-001-100			10	0,8	45	4	☑	
4JJCR-008-001-120			12	0,8	50	4	☑	
4JJCR-010-0002-040		1	R 0,02	4	1	45	4	☑
4JJCR-010-0002-060				6	1	45	4	☑
4JJCR-010-0002-080				8	1	45	4	☑
4JJCR-010-0002-100				10	1	50	4	☑
4JJCR-010-0002-120	12			1	50	4	☑	
4JJCR-010-0002-140	14			1	50	4	☑	
4JJCR-010-0002-160	16			1	50	4	☑	
4JJCR-010-0002-200	20			1	50	4	☑	
4JJCR-010-0005-040	R 0,05		4	1	45	4	☑	
4JJCR-010-0005-060			6	1	45	4	☑	
4JJCR-010-0005-080			8	1	45	4	☑	
4JJCR-010-0005-100			10	1	50	4	☑	
4JJCR-010-0005-120			12	1	50	4	☑	
4JJCR-010-0005-140			14	1	50	4	☑	
4JJCR-010-0005-160			16	1	50	4	☑	
4JJCR-010-0005-200			20	1	50	4	☑	
4JJCR-010-001-040	1	R 0,1	4	1	45	4	☑	
4JJCR-010-001-060			6	1	45	4	☑	
4JJCR-010-001-080			8	1	45	4	☑	
4JJCR-010-001-100			10	1	50	4	☑	
4JJCR-010-001-120			12	1	50	4	☑	
4JJCR-010-001-140			14	1	50	4	☑	
4JJCR-010-001-160			16	1	50	4	☑	
4JJCR-010-001-200			20	1	50	4	☑	
4JJCR-010-002-040		R 0,2	4	1	45	4	☑	
4JJCR-010-002-060			6	1	45	4	☑	
4JJCR-010-002-080			8	1	45	4	☑	
4JJCR-010-002-100			10	1	50	4	☑	
4JJCR-010-002-120			12	1	50	4	☑	
4JJCR-010-002-140			14	1	50	4	☑	
4JJCR-010-002-160			16	1	50	4	☑	
4JJCR-010-002-200			20	1	50	4	☑	
4JJCR-010-003-040	R 0,3	4	1	45	4	☑		
4JJCR-010-003-060		6	1	45	4	☑		

NOVINKA

Objednáací číslo	D (mm)	R (mm)	L2 (mm)	L1 (mm)	L (mm)	d h5 (mm)	Standardní položka	Objednáací číslo	D (mm)	R (mm)	L2 (mm)	L1 (mm)	L (mm)	d h5 (mm)	Standardní položka		
4JJCR-010-003-080	1	R 0,3	8	1	45	4	<input checked="" type="checkbox"/>	4JJCR-015-0005-080	1,5	R 0,05	8	1,5	45	4	<input checked="" type="checkbox"/>		
4JJCR-010-003-100			10	1	50	4	<input checked="" type="checkbox"/>	4JJCR-015-0005-100			10	1,5	50	4	<input checked="" type="checkbox"/>		
4JJCR-010-003-120			12	1	50	4	<input checked="" type="checkbox"/>	4JJCR-015-0005-120			12	1,5	50	4	<input checked="" type="checkbox"/>		
4JJCR-010-003-140			14	1	50	4	<input checked="" type="checkbox"/>	4JJCR-015-0005-140			14	1,5	50	4	<input checked="" type="checkbox"/>		
4JJCR-010-003-160			16	1	50	4	<input checked="" type="checkbox"/>	4JJCR-015-0005-160			16	1,5	50	4	<input checked="" type="checkbox"/>		
4JJCR-010-003-200			20	1	50	4	<input checked="" type="checkbox"/>	4JJCR-015-0005-200			20	1,5	50	4	<input checked="" type="checkbox"/>		
4JJCR-012-0002-040			1,2	R 0,02	4	1,2	45	4			<input checked="" type="checkbox"/>	4JJCR-015-0005-220	R 0,1	22	1,5	60	4
4JJCR-012-0002-060	6	1,2			45	4	<input checked="" type="checkbox"/>	4JJCR-015-001-060	6	1,5	45	4		<input checked="" type="checkbox"/>			
4JJCR-012-0002-080	8	1,2			45	4	<input checked="" type="checkbox"/>	4JJCR-015-001-080	8	1,5	45	4		<input checked="" type="checkbox"/>			
4JJCR-012-0002-100	10	1,2			50	4	<input checked="" type="checkbox"/>	4JJCR-015-001-100	10	1,5	50	4		<input checked="" type="checkbox"/>			
4JJCR-012-0002-120	12	1,2			50	4	<input checked="" type="checkbox"/>	4JJCR-015-001-120	12	1,5	50	4		<input checked="" type="checkbox"/>			
4JJCR-012-0002-140	14	1,2			50	4	<input checked="" type="checkbox"/>	4JJCR-015-001-140	14	1,5	50	4		<input checked="" type="checkbox"/>			
4JJCR-012-0002-160	16	1,2			50	4	<input checked="" type="checkbox"/>	4JJCR-015-001-160	16	1,5	50	4		<input checked="" type="checkbox"/>			
4JJCR-012-0002-200	20	1,2		50	4	<input checked="" type="checkbox"/>	4JJCR-015-001-200	20	1,5	50	4	<input checked="" type="checkbox"/>					
4JJCR-012-0005-040	1,2	R 0,05		4	1,2	45	4	<input checked="" type="checkbox"/>	4JJCR-015-001-220	R 0,2	22	1,5	60	4	<input checked="" type="checkbox"/>		
4JJCR-012-0005-060				6	1,2	45	4	<input checked="" type="checkbox"/>	4JJCR-015-002-060		6	1,5	45	4	<input checked="" type="checkbox"/>		
4JJCR-012-0005-080				8	1,2	45	4	<input checked="" type="checkbox"/>	4JJCR-015-002-080		8	1,5	45	4	<input checked="" type="checkbox"/>		
4JJCR-012-0005-100				10	1,2	50	4	<input checked="" type="checkbox"/>	4JJCR-015-002-100		10	1,5	50	4	<input checked="" type="checkbox"/>		
4JJCR-012-0005-120				12	1,2	50	4	<input checked="" type="checkbox"/>	4JJCR-015-002-120		12	1,5	50	4	<input checked="" type="checkbox"/>		
4JJCR-012-0005-140				14	1,2	50	4	<input checked="" type="checkbox"/>	4JJCR-015-002-140		14	1,5	50	4	<input checked="" type="checkbox"/>		
4JJCR-012-0005-160			16	1,2	50	4	<input checked="" type="checkbox"/>	4JJCR-015-002-160	16		1,5	50	4	<input checked="" type="checkbox"/>			
4JJCR-012-0005-200		20	1,2	50	4	<input checked="" type="checkbox"/>	4JJCR-015-002-200	20	1,5	50	4	<input checked="" type="checkbox"/>					
4JJCR-012-001-040		1,2	R 0,1	4	1,2	45	4	<input checked="" type="checkbox"/>	4JJCR-015-002-220	R 0,3	22	1,5	60	4	<input checked="" type="checkbox"/>		
4JJCR-012-001-060				6	1,2	45	4	<input checked="" type="checkbox"/>	4JJCR-015-002-250		25	1,5	60	4	<input checked="" type="checkbox"/>		
4JJCR-012-001-080				8	1,2	45	4	<input checked="" type="checkbox"/>	4JJCR-015-003-060		6	1,5	45	4	<input checked="" type="checkbox"/>		
4JJCR-012-001-100				10	1,2	50	4	<input checked="" type="checkbox"/>	4JJCR-015-003-080		8	1,5	45	4	<input checked="" type="checkbox"/>		
4JJCR-012-001-120				12	1,2	50	4	<input checked="" type="checkbox"/>	4JJCR-015-003-100		10	1,5	50	4	<input checked="" type="checkbox"/>		
4JJCR-012-001-140				14	1,2	50	4	<input checked="" type="checkbox"/>	4JJCR-015-003-120		12	1,5	50	4	<input checked="" type="checkbox"/>		
4JJCR-012-001-160	16			1,2	50	4	<input checked="" type="checkbox"/>	4JJCR-015-003-140	14		1,5	50	4	<input checked="" type="checkbox"/>			
4JJCR-012-001-200	20		1,2	50	4	<input checked="" type="checkbox"/>	4JJCR-015-003-160	16	1,5	50	4	<input checked="" type="checkbox"/>					
4JJCR-012-002-040	1,2		R 0,2	4	1,2	45	4	<input checked="" type="checkbox"/>	4JJCR-015-003-200	R 0,5	20	1,5	50	4	<input checked="" type="checkbox"/>		
4JJCR-012-002-060				6	1,2	45	4	<input checked="" type="checkbox"/>	4JJCR-015-003-220		22	1,5	60	4	<input checked="" type="checkbox"/>		
4JJCR-012-002-080				8	1,2	45	4	<input checked="" type="checkbox"/>	4JJCR-015-003-250		25	1,5	60	4	<input checked="" type="checkbox"/>		
4JJCR-012-002-100				10	1,2	50	4	<input checked="" type="checkbox"/>	4JJCR-015-005-060		6	1,5	45	4	<input checked="" type="checkbox"/>		
4JJCR-012-002-120				12	1,2	50	4	<input checked="" type="checkbox"/>	4JJCR-015-005-080		8	1,5	45	4	<input checked="" type="checkbox"/>		
4JJCR-012-002-140				14	1,2	50	4	<input checked="" type="checkbox"/>	4JJCR-015-005-100		10	1,5	50	4	<input checked="" type="checkbox"/>		
4JJCR-012-002-160		16		1,2	50	4	<input checked="" type="checkbox"/>	4JJCR-015-005-120	12		1,5	50	4	<input checked="" type="checkbox"/>			
4JJCR-012-002-200		20	1,2	50	4	<input checked="" type="checkbox"/>	4JJCR-015-005-140	14	1,5	50	4	<input checked="" type="checkbox"/>					
4JJCR-012-003-040		1,5	R 0,3	4	1,2	45	4	<input checked="" type="checkbox"/>	4JJCR-015-005-160	R 0,5	16	1,5	50	4	<input checked="" type="checkbox"/>		
4JJCR-012-003-060				6	1,2	45	4	<input checked="" type="checkbox"/>	4JJCR-015-005-200		20	1,5	50	4	<input checked="" type="checkbox"/>		
4JJCR-012-003-080				8	1,2	45	4	<input checked="" type="checkbox"/>	4JJCR-015-005-220		22	1,5	60	4	<input checked="" type="checkbox"/>		
4JJCR-012-003-100				10	1,2	50	4	<input checked="" type="checkbox"/>	4JJCR-015-005-250		25	1,5	60	4	<input checked="" type="checkbox"/>		
4JJCR-012-003-120				12	1,2	50	4	<input checked="" type="checkbox"/>	4JJCR-020-0002-060		6	2	45	4	<input checked="" type="checkbox"/>		
4JJCR-015-0002-060				1,5	R 0,02	6	1,5	45	4		<input checked="" type="checkbox"/>	4JJCR-020-0002-080	R 0,02	8	2	45	4
4JJCR-015-0002-080	8					1,5	45	4	<input checked="" type="checkbox"/>		4JJCR-020-0002-100	10		2	50	4	<input checked="" type="checkbox"/>
4JJCR-015-0002-100	10		1,5			50	4	<input checked="" type="checkbox"/>	4JJCR-020-0002-120	12	2	50		4	<input checked="" type="checkbox"/>		
4JJCR-015-0002-120	12		1,5			50	4	<input checked="" type="checkbox"/>	4JJCR-020-0002-140	14	2	50		4	<input checked="" type="checkbox"/>		
4JJCR-015-0002-140	14		1,5			50	4	<input checked="" type="checkbox"/>	4JJCR-020-0002-160	16	2	50		4	<input checked="" type="checkbox"/>		
4JJCR-015-0002-160	16		1,5			50	4	<input checked="" type="checkbox"/>	4JJCR-020-0002-200	20	2	50		4	<input checked="" type="checkbox"/>		
4JJCR-015-0002-200	20		1,5			50	4	<input checked="" type="checkbox"/>	4JJCR-020-0002-250	25	2	60		4	<input checked="" type="checkbox"/>		
4JJCR-015-0002-220	22		1,5			60	4	<input checked="" type="checkbox"/>	4JJCR-020-0002-300	30	2	70		4	<input checked="" type="checkbox"/>		
4JJCR-015-0005-060	R 0,05		6			1,5	45	4	<input checked="" type="checkbox"/>	4JJCR-020-0005-060	R 0,05	6		2	45	4	<input checked="" type="checkbox"/>

NOVINKA

Objednáací číslo	D (mm)	R (mm)	L2 (mm)	L1 (mm)	L (mm)	d h5 (mm)	Standardní položka	Objednáací číslo	D (mm)	R (mm)	L2 (mm)	L1 (mm)	L (mm)	d h5 (mm)	Standardní položka	
4JJCR-020-0005-080	2	R 0,05	8	2	45	4	<input checked="" type="checkbox"/>	4JJCR-025-002-250	2,5	R 0,2	25	2,5	60	4	<input checked="" type="checkbox"/>	
4JJCR-020-0005-100			10	2	50	4	<input checked="" type="checkbox"/>	4JJCR-025-002-300			30	2,5	70	4	<input checked="" type="checkbox"/>	
4JJCR-020-0005-120			12	2	50	4	<input checked="" type="checkbox"/>	4JJCR-025-003-100		R 0,3	10	2,5	50	4	<input checked="" type="checkbox"/>	
4JJCR-020-0005-140			14	2	50	4	<input checked="" type="checkbox"/>	4JJCR-025-003-160			16	2,5	50	4	<input checked="" type="checkbox"/>	
4JJCR-020-0005-160			16	2	50	4	<input checked="" type="checkbox"/>	4JJCR-025-003-200			20	2,5	50	4	<input checked="" type="checkbox"/>	
4JJCR-020-0005-200			20	2	50	4	<input checked="" type="checkbox"/>	4JJCR-025-003-250			25	2,5	60	4	<input checked="" type="checkbox"/>	
4JJCR-020-0005-250			25	2	60	4	<input checked="" type="checkbox"/>	4JJCR-025-003-300		30	2,5	70	4	<input checked="" type="checkbox"/>		
4JJCR-020-0005-300			30	2	70	4	<input checked="" type="checkbox"/>	4JJCR-025-005-100		R 0,5	10	2,5	50	4	<input checked="" type="checkbox"/>	
4JJCR-020-001-060			6	2	45	4	<input checked="" type="checkbox"/>	4JJCR-025-005-160			16	2,5	50	4	<input checked="" type="checkbox"/>	
4JJCR-020-001-080			8	2	45	4	<input checked="" type="checkbox"/>	4JJCR-025-005-200			20	2,5	50	4	<input checked="" type="checkbox"/>	
4JJCR-020-001-100		10	2	50	4	<input checked="" type="checkbox"/>	4JJCR-025-005-250	25	2,5		60	4	<input checked="" type="checkbox"/>			
4JJCR-020-001-120		12	2	50	4	<input checked="" type="checkbox"/>	4JJCR-025-005-300	30	2,5	70	4	<input checked="" type="checkbox"/>				
4JJCR-020-001-140		R 0,1	14	2	50	4	<input checked="" type="checkbox"/>	4JJCR-030-001-100	R 0,1	10	3	50	6	<input checked="" type="checkbox"/>		
4JJCR-020-001-160			16	2	50	4	<input checked="" type="checkbox"/>	4JJCR-030-001-120		12	3	50	6	<input checked="" type="checkbox"/>		
4JJCR-020-001-200			20	2	50	4	<input checked="" type="checkbox"/>	4JJCR-030-001-160		16	3	55	6	<input checked="" type="checkbox"/>		
4JJCR-020-001-250			25	2	60	4	<input checked="" type="checkbox"/>	4JJCR-030-001-200		20	3	60	6	<input checked="" type="checkbox"/>		
4JJCR-020-001-300			30	2	70	4	<input checked="" type="checkbox"/>	4JJCR-030-001-250		25	3	65	6	<input checked="" type="checkbox"/>		
4JJCR-020-002-060			6	2	45	4	<input checked="" type="checkbox"/>	4JJCR-030-001-300		30	3	70	6	<input checked="" type="checkbox"/>		
4JJCR-020-002-080			8	2	45	4	<input checked="" type="checkbox"/>	4JJCR-030-001-350		35	3	75	6	<input checked="" type="checkbox"/>		
4JJCR-020-002-100			10	2	50	4	<input checked="" type="checkbox"/>	4JJCR-030-001-400		40	3	80	6	<input checked="" type="checkbox"/>		
4JJCR-020-002-120			12	2	50	4	<input checked="" type="checkbox"/>	4JJCR-030-001-450		45	3	90	6	<input checked="" type="checkbox"/>		
4JJCR-020-002-140			R 0,2	14	2	50	4	<input checked="" type="checkbox"/>		4JJCR-030-002-100	R 0,2	10	3	50	6	<input checked="" type="checkbox"/>
4JJCR-020-002-160		16		2	50	4	<input checked="" type="checkbox"/>	4JJCR-030-002-120	12	3		50	6	<input checked="" type="checkbox"/>		
4JJCR-020-002-200		20		2	50	4	<input checked="" type="checkbox"/>	4JJCR-030-002-160	16	3		55	6	<input checked="" type="checkbox"/>		
4JJCR-020-002-250		25		2	60	4	<input checked="" type="checkbox"/>	4JJCR-030-002-200	20	3		60	6	<input checked="" type="checkbox"/>		
4JJCR-020-002-300		30		2	70	4	<input checked="" type="checkbox"/>	4JJCR-030-002-250	25	3		65	6	<input checked="" type="checkbox"/>		
4JJCR-020-003-060		6		2	45	4	<input checked="" type="checkbox"/>	4JJCR-030-002-300	30	3		70	6	<input checked="" type="checkbox"/>		
4JJCR-020-003-080		8		2	45	4	<input checked="" type="checkbox"/>	4JJCR-030-002-350	35	3		75	6	<input checked="" type="checkbox"/>		
4JJCR-020-003-100		10		2	50	4	<input checked="" type="checkbox"/>	4JJCR-030-002-400	40	3		80	6	<input checked="" type="checkbox"/>		
4JJCR-020-003-120		12		2	50	4	<input checked="" type="checkbox"/>	4JJCR-030-002-450	45	3		90	6	<input checked="" type="checkbox"/>		
4JJCR-020-003-140	R 0,3	14		2	50	4	<input checked="" type="checkbox"/>	4JJCR-030-003-100	R 0,3	10		3	50	6	<input checked="" type="checkbox"/>	
4JJCR-020-003-160		16	2	50	4	<input checked="" type="checkbox"/>	4JJCR-030-003-120	12		3	50	6	<input checked="" type="checkbox"/>			
4JJCR-020-003-200		20	2	50	4	<input checked="" type="checkbox"/>	4JJCR-030-003-160	16		3	55	6	<input checked="" type="checkbox"/>			
4JJCR-020-003-250		25	2	60	4	<input checked="" type="checkbox"/>	4JJCR-030-003-200	20		3	60	6	<input checked="" type="checkbox"/>			
4JJCR-020-003-300		30	2	70	4	<input checked="" type="checkbox"/>	4JJCR-030-003-250	25		3	65	6	<input checked="" type="checkbox"/>			
4JJCR-020-005-060		6	2	45	4	<input checked="" type="checkbox"/>	4JJCR-030-003-300	30		3	70	6	<input checked="" type="checkbox"/>			
4JJCR-020-005-080		8	2	45	4	<input checked="" type="checkbox"/>	4JJCR-030-003-350	35		3	75	6	<input checked="" type="checkbox"/>			
4JJCR-020-005-100		10	2	50	4	<input checked="" type="checkbox"/>	4JJCR-030-003-400	40		3	80	6	<input checked="" type="checkbox"/>			
4JJCR-020-005-120		12	2	50	4	<input checked="" type="checkbox"/>	4JJCR-030-003-450	45		3	90	6	<input checked="" type="checkbox"/>			
4JJCR-020-005-140		R 0,5	14	2	50	4	<input checked="" type="checkbox"/>	4JJCR-030-005-100		R 0,5	10	3	50	6	<input checked="" type="checkbox"/>	
4JJCR-020-005-160	16		2	50	4	<input checked="" type="checkbox"/>	4JJCR-030-005-120	12	3		50	6	<input checked="" type="checkbox"/>			
4JJCR-020-005-200	20		2	50	4	<input checked="" type="checkbox"/>	4JJCR-030-005-160	16	3		55	6	<input checked="" type="checkbox"/>			
4JJCR-020-005-250	25		2	60	4	<input checked="" type="checkbox"/>	4JJCR-030-005-200	20	3		60	6	<input checked="" type="checkbox"/>			
4JJCR-020-005-300	30		2	70	4	<input checked="" type="checkbox"/>	4JJCR-030-005-250	25	3		65	6	<input checked="" type="checkbox"/>			
4JJCR-025-001-100	2,5		R 0,1	10	2,5	50	4	<input checked="" type="checkbox"/>	4JJCR-030-005-300		R 0,5	30	3	70	6	<input checked="" type="checkbox"/>
4JJCR-025-001-160				16	2,5	50	4	<input checked="" type="checkbox"/>	4JJCR-030-005-350			35	3	75	6	<input checked="" type="checkbox"/>
4JJCR-025-001-200				20	2,5	50	4	<input checked="" type="checkbox"/>	4JJCR-030-005-400			40	3	80	6	<input checked="" type="checkbox"/>
4JJCR-025-001-250				25	2,5	60	4	<input checked="" type="checkbox"/>	4JJCR-030-005-450			45	3	90	6	<input checked="" type="checkbox"/>
4JJCR-025-001-300				30	2,5	70	4	<input checked="" type="checkbox"/>	4JJCR-030-005-500			50	3	100	6	<input checked="" type="checkbox"/>
4JJCR-025-002-100		R 0,2	10	2,5	50	4	<input checked="" type="checkbox"/>	4JJCR-030-010-100	R 1	10	3	50	6	<input checked="" type="checkbox"/>		
4JJCR-025-002-160			16	2,5	50	4	<input checked="" type="checkbox"/>	4JJCR-030-010-120		12	3	50	6	<input checked="" type="checkbox"/>		
4JJCR-025-002-200			20	2,5	50	4	<input checked="" type="checkbox"/>	4JJCR-030-010-160		16	3	55	6	<input checked="" type="checkbox"/>		

NOVINKA

Objednáací číslo	D (mm)	R (mm)	L2 (mm)	L1 (mm)	L (mm)	d h5 (mm)	Standardní položka	Objednáací číslo	D (mm)	R (mm)	L2 (mm)	L1 (mm)	L (mm)	d h5 (mm)	Standardní položka	
4JJCR-030-010-200	3	R 1	20	3	60	6	<input checked="" type="checkbox"/>	4JJCR-050-001-160	5	R 0,1	16	5	60	6	<input checked="" type="checkbox"/>	
4JJCR-030-010-250			25	3	65	6	<input checked="" type="checkbox"/>	4JJCR-050-001-300			30	5	70	6	<input checked="" type="checkbox"/>	
4JJCR-030-010-300			30	3	70	6	<input checked="" type="checkbox"/>	4JJCR-050-001-400			40	5	80	6	<input checked="" type="checkbox"/>	
4JJCR-030-010-350			35	3	75	6	<input checked="" type="checkbox"/>	4JJCR-050-002-160		R 0,2	16	5	60	6	<input checked="" type="checkbox"/>	
4JJCR-030-010-400			40	3	80	6	<input checked="" type="checkbox"/>	4JJCR-050-002-300			30	5	70	6	<input checked="" type="checkbox"/>	
4JJCR-030-010-450			45	3	90	6	<input checked="" type="checkbox"/>	4JJCR-050-002-400			40	5	80	6	<input checked="" type="checkbox"/>	
4JJCR-030-010-500			50	3	100	6	<input checked="" type="checkbox"/>	4JJCR-050-003-160		R 0,3	16	5	60	6	<input checked="" type="checkbox"/>	
4JJCR-040-001-130	4	R 0,1	13	4	55	6	<input checked="" type="checkbox"/>	4JJCR-050-003-300	30		5	70	6	<input checked="" type="checkbox"/>		
4JJCR-040-001-160			16	4	55	6	<input checked="" type="checkbox"/>	4JJCR-050-003-400	40		5	80	6	<input checked="" type="checkbox"/>		
4JJCR-040-001-200			20	4	60	6	<input checked="" type="checkbox"/>	4JJCR-050-005-160	R 0,5	16	5	60	6	<input checked="" type="checkbox"/>		
4JJCR-040-001-250			25	4	65	6	<input checked="" type="checkbox"/>	4JJCR-050-005-300		30	5	70	6	<input checked="" type="checkbox"/>		
4JJCR-040-001-300			30	4	70	6	<input checked="" type="checkbox"/>	4JJCR-050-005-400		40	5	80	6	<input checked="" type="checkbox"/>		
4JJCR-040-001-350			35	4	75	6	<input checked="" type="checkbox"/>	4JJCR-050-005-500	R 1	50	5	100	6	<input checked="" type="checkbox"/>		
4JJCR-040-001-400			40	4	80	6	<input checked="" type="checkbox"/>	4JJCR-050-005-600		60	5	110	6	<input checked="" type="checkbox"/>		
4JJCR-040-002-130			R 0,2	13	4	55	6	<input checked="" type="checkbox"/>		4JJCR-050-010-160	R 0,1	16	5	60	6	<input checked="" type="checkbox"/>
4JJCR-040-002-160		16		4	55	6	<input checked="" type="checkbox"/>	4JJCR-050-010-300	30	5		70	6	<input checked="" type="checkbox"/>		
4JJCR-040-002-200		20		4	60	6	<input checked="" type="checkbox"/>	4JJCR-050-010-400	40	5		80	6	<input checked="" type="checkbox"/>		
4JJCR-040-002-250		25		4	65	6	<input checked="" type="checkbox"/>	4JJCR-050-010-500	R 0,2	50	5	100	6	<input checked="" type="checkbox"/>		
4JJCR-040-002-300		30		4	70	6	<input checked="" type="checkbox"/>	4JJCR-050-010-600		60	5	110	6	<input checked="" type="checkbox"/>		
4JJCR-040-002-350		35		4	75	6	<input checked="" type="checkbox"/>	4JJCR-060-001-200		R 0,1	20	7	60	6	<input checked="" type="checkbox"/>	
4JJCR-040-002-400		40		4	80	6	<input checked="" type="checkbox"/>	4JJCR-060-001-400	40		7	80	6	<input checked="" type="checkbox"/>		
4JJCR-040-002-450		45		4	90	6	<input checked="" type="checkbox"/>	4JJCR-060-001-500	50		7	100	6	<input checked="" type="checkbox"/>		
4JJCR-040-002-500		50	4	100	6	<input checked="" type="checkbox"/>	4JJCR-060-002-200	R 0,2	20	7	60	6	<input checked="" type="checkbox"/>			
4JJCR-040-003-130	4	R 0,3	13	4	55	6	<input checked="" type="checkbox"/>		4JJCR-060-002-400	40	7	80	6	<input checked="" type="checkbox"/>		
4JJCR-040-003-160			16	4	55	6	<input checked="" type="checkbox"/>		4JJCR-060-002-500	50	7	100	6	<input checked="" type="checkbox"/>		
4JJCR-040-003-200			20	4	60	6	<input checked="" type="checkbox"/>	4JJCR-060-003-200	R 0,3	20	7	60	6	<input checked="" type="checkbox"/>		
4JJCR-040-003-250			25	4	65	6	<input checked="" type="checkbox"/>	4JJCR-060-003-400		40	7	80	6	<input checked="" type="checkbox"/>		
4JJCR-040-003-300			30	4	70	6	<input checked="" type="checkbox"/>	4JJCR-060-003-500		50	7	100	6	<input checked="" type="checkbox"/>		
4JJCR-040-003-350			35	4	75	6	<input checked="" type="checkbox"/>	4JJCR-060-005-200	R 0,5	20	7	60	6	<input checked="" type="checkbox"/>		
4JJCR-040-003-400			40	4	80	6	<input checked="" type="checkbox"/>	4JJCR-060-005-400		40	7	80	6	<input checked="" type="checkbox"/>		
4JJCR-040-003-450			45	4	90	6	<input checked="" type="checkbox"/>	4JJCR-060-005-500		50	7	100	6	<input checked="" type="checkbox"/>		
4JJCR-040-003-500		50	4	100	6	<input checked="" type="checkbox"/>	4JJCR-060-005-600	R 1	60	7	110	6	<input checked="" type="checkbox"/>			
4JJCR-040-005-130		R 0,5	13	4	55	6	<input checked="" type="checkbox"/>		4JJCR-060-010-200	20	7	60	6	<input checked="" type="checkbox"/>		
4JJCR-040-005-160			16	4	55	6	<input checked="" type="checkbox"/>		4JJCR-060-010-400	40	7	80	6	<input checked="" type="checkbox"/>		
4JJCR-040-005-200			20	4	60	6	<input checked="" type="checkbox"/>	4JJCR-060-010-500	50	7	100	6	<input checked="" type="checkbox"/>			
4JJCR-040-005-250			25	4	65	6	<input checked="" type="checkbox"/>	4JJCR-060-010-600	R 1,5	60	7	110	6	<input checked="" type="checkbox"/>		
4JJCR-040-005-300			30	4	70	6	<input checked="" type="checkbox"/>	4JJCR-060-015-200		20	7	60	6	<input checked="" type="checkbox"/>		
4JJCR-040-005-350			35	4	75	6	<input checked="" type="checkbox"/>	4JJCR-060-015-400		40	7	80	6	<input checked="" type="checkbox"/>		
4JJCR-040-005-400			40	4	80	6	<input checked="" type="checkbox"/>	4JJCR-060-015-500	50	7	100	6	<input checked="" type="checkbox"/>			
4JJCR-040-005-450	45		4	90	6	<input checked="" type="checkbox"/>	4JJCR-060-020-300	R 2	30	7	70	6	<input checked="" type="checkbox"/>			
4JJCR-040-005-500	50	4	100	6	<input checked="" type="checkbox"/>	4JJCR-060-020-400	40		7	80	6	<input checked="" type="checkbox"/>				
4JJCR-040-005-550	55	4	100	6	<input checked="" type="checkbox"/>	4JJCR-060-020-500	50		7	100	6	<input checked="" type="checkbox"/>				
4JJCR-040-010-130	4	R 1	13	4	55	6	<input checked="" type="checkbox"/>	4JJCR-080-002-220	8	R 0,2	22	9	65	8	<input checked="" type="checkbox"/>	
4JJCR-040-010-160			16	4	55	6	<input checked="" type="checkbox"/>	4JJCR-080-002-400			R 0,3	40	9	100	8	<input checked="" type="checkbox"/>
4JJCR-040-010-200			20	4	60	6	<input checked="" type="checkbox"/>	4JJCR-080-003-220				22	9	65	8	<input checked="" type="checkbox"/>
4JJCR-040-010-250			25	4	65	6	<input checked="" type="checkbox"/>	4JJCR-080-003-400	R 0,5	40		9	100	8	<input checked="" type="checkbox"/>	
4JJCR-040-010-300			30	4	70	6	<input checked="" type="checkbox"/>	4JJCR-080-005-220		22	9	65	8	<input checked="" type="checkbox"/>		
4JJCR-040-010-350			35	4	75	6	<input checked="" type="checkbox"/>	4JJCR-080-005-400		R 1	40	9	100	8	<input checked="" type="checkbox"/>	
4JJCR-040-010-400			40	4	80	6	<input checked="" type="checkbox"/>	4JJCR-080-005-500	50		9	120	8	<input checked="" type="checkbox"/>		
4JJCR-040-010-450			45	4	90	6	<input checked="" type="checkbox"/>	4JJCR-080-005-600	60		9	120	8	<input checked="" type="checkbox"/>		
4JJCR-040-010-500			50	4	100	6	<input checked="" type="checkbox"/>	4JJCR-080-010-220	R 1	22	9	65	8	<input checked="" type="checkbox"/>		
4JJCR-040-010-550			55	4	100	6	<input checked="" type="checkbox"/>	4JJCR-080-010-400		40	9	100	8	<input checked="" type="checkbox"/>		

NOVINKA

Objednací číslo	D (mm)	R (mm)	L2 (mm)	L1 (mm)	L (mm)	d h5 (mm)	Standardní položka	
4JJCR-080-010-500	8	R 1	50	9	120	8	<input checked="" type="checkbox"/>	
4JJCR-080-010-600			60	9	120	8	<input checked="" type="checkbox"/>	
4JJCR-080-015-220		R 1,5	22	9	65	8	<input checked="" type="checkbox"/>	
4JJCR-080-015-400			40	9	100	8	<input checked="" type="checkbox"/>	
4JJCR-080-020-220		R 2	22	9	65	8	<input checked="" type="checkbox"/>	
4JJCR-080-020-400			40	9	100	8	<input checked="" type="checkbox"/>	
4JJCR-080-020-500			50	9	120	8	<input checked="" type="checkbox"/>	
4JJCR-100-002-240		10	R 0,2	24	11	70	10	<input checked="" type="checkbox"/>
4JJCR-100-002-400	40			11	100	10	<input checked="" type="checkbox"/>	
4JJCR-100-003-240	R 0,3		24	11	70	10	<input checked="" type="checkbox"/>	
4JJCR-100-003-400			40	11	100	10	<input checked="" type="checkbox"/>	
4JJCR-100-005-240	R 0,5		24	11	70	10	<input checked="" type="checkbox"/>	
4JJCR-100-005-400			40	11	100	10	<input checked="" type="checkbox"/>	
4JJCR-100-005-500			50	11	120	10	<input checked="" type="checkbox"/>	
4JJCR-100-005-600			60	11	120	10	<input checked="" type="checkbox"/>	
4JJCR-100-010-240	R 1		24	11	70	10	<input checked="" type="checkbox"/>	
4JJCR-100-010-400			40	11	100	10	<input checked="" type="checkbox"/>	
4JJCR-100-010-500			50	11	120	10	<input checked="" type="checkbox"/>	
4JJCR-100-010-600			60	11	120	10	<input checked="" type="checkbox"/>	
4JJCR-100-015-240			R 1,5	24	11	70	10	<input checked="" type="checkbox"/>
4JJCR-100-015-400				40	11	100	10	<input checked="" type="checkbox"/>
4JJCR-100-020-240			R 2	24	11	70	10	<input checked="" type="checkbox"/>
4JJCR-100-020-400				40	11	100	10	<input checked="" type="checkbox"/>
4JJCR-100-020-500	50			11	120	10	<input checked="" type="checkbox"/>	
4JJCR-100-025-240	R 2,5		24	11	70	10	<input checked="" type="checkbox"/>	
4JJCR-120-003-260	12		R 2,5	26	13	80	12	<input checked="" type="checkbox"/>
4JJCR-120-005-260				26	13	80	12	<input checked="" type="checkbox"/>
4JJCR-120-005-400		R 0,5	40	13	110	12	<input checked="" type="checkbox"/>	
4JJCR-120-005-600			60	13	130	12	<input checked="" type="checkbox"/>	
4JJCR-120-010-260			R 1	26	13	80	12	<input checked="" type="checkbox"/>
4JJCR-120-010-400		40		13	110	12	<input checked="" type="checkbox"/>	
4JJCR-120-010-600		60		13	130	12	<input checked="" type="checkbox"/>	
4JJCR-120-015-260		R 1,5		26	13	80	12	<input checked="" type="checkbox"/>
4JJCR-120-020-260			26	13	80	12	<input checked="" type="checkbox"/>	
4JJCR-120-020-400		R 2	40	13	110	12	<input checked="" type="checkbox"/>	
4JJCR-120-030-260			R 3	26	13	80	12	<input checked="" type="checkbox"/>

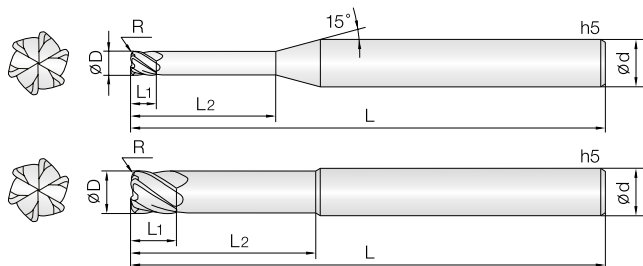

- **Určeno pro kalené oceli (52 - 68 HRC)**
- Vysoká odolnost proti opotřebení díky novému PVD povlaku s vysokým obsahem Si
- Velmi přesné tolerance řezných hran
- Minimalizace vyštipování díky rohovému rádiu
- Široký sortiment rádiusů a vyložení pro optimální výběr nástroje
- Vynikající výkon při vysokých řezných rychlostech díky 0,2 µm tvrdokovu

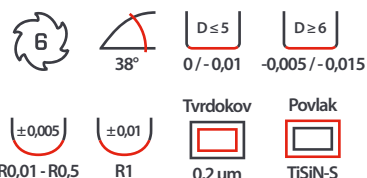

NOVINKA

Objednací číslo	D (mm)	R (mm)	L2 (mm)	L1 (mm)	L (mm)	d h5 (mm)	Standardní položka	
6JJCR-030-001-120	3	R 0,1	12	3	55	6	☑	
6JJCR-030-001-160			16	3	60	6	☑	
6JJCR-030-001-200			20	3	65	6	☑	
6JJCR-030-001-250			25	3	70	6	☑	
6JJCR-030-001-300			30	3	75	6	☑	
6JJCR-030-002-120			R 0,2	12	3	55	6	☑
6JJCR-030-002-160		16		3	60	6	☑	
6JJCR-030-002-200		20		3	65	6	☑	
6JJCR-030-002-250		25		3	70	6	☑	
6JJCR-030-002-300		30		3	75	6	☑	
6JJCR-030-003-120		R 0,3		12	3	55	6	☑
6JJCR-030-003-160			16	3	60	6	☑	
6JJCR-030-003-200			20	3	65	6	☑	
6JJCR-030-003-250			25	3	70	6	☑	
6JJCR-030-003-300			30	3	75	6	☑	
6JJCR-030-005-120			R 0,5	12	3	55	6	☑
6JJCR-030-005-160		16		3	60	6	☑	
6JJCR-030-005-200		20		3	65	6	☑	
6JJCR-030-005-250		25		3	70	6	☑	
6JJCR-030-005-300		30		3	75	6	☑	
6JJCR-030-010-120		R 1		12	3	55	6	☑
6JJCR-030-010-160			16	3	60	6	☑	
6JJCR-030-010-200			20	3	65	6	☑	
6JJCR-030-010-250			25	3	70	6	☑	
6JJCR-030-010-300			30	3	75	6	☑	
6JJCR-040-001-120			4	R 0,1	12	4	55	6
6JJCR-040-001-160		16			4	60	6	☑
6JJCR-040-001-200		20			4	65	6	☑
6JJCR-040-001-250		25			4	70	6	☑
6JJCR-040-001-300		30			4	75	6	☑
6JJCR-040-002-120	R 0,2	12			4	55	6	☑
6JJCR-040-002-160		16		4	60	6	☑	
6JJCR-040-002-200		20		4	65	6	☑	
6JJCR-040-002-250		25		4	70	6	☑	
6JJCR-040-002-300		30		4	75	6	☑	
6JJCR-040-003-120		R 0,3		12	4	55	6	☑
6JJCR-040-003-160	16			4	60	6	☑	
6JJCR-040-003-200	20			4	65	6	☑	
6JJCR-040-003-250	25			4	70	6	☑	
6JJCR-040-003-300	30			4	75	6	☑	
6JJCR-040-005-210	R 0,5			21	6	60	6	☑
6JJCR-040-005-310		31		6	70	6	☑	
6JJCR-040-005-410		41		6	80	6	☑	
6JJCR-050-001-160		R 0,1		16	5	60	6	☑
6JJCR-050-001-200				20	5	65	6	☑
6JJCR-050-001-300				30	5	75	6	☑
6JJCR-050-002-160	R 0,2			16	5	60	6	☑
6JJCR-050-002-200				20	5	65	6	☑
6JJCR-050-002-300				30	5	75	6	☑
6JJCR-050-003-160	R 0,3	16		5	60	6	☑	
6JJCR-050-003-200		20		5	65	6	☑	
6JJCR-050-003-300		30		5	75	6	☑	
6JJCR-050-005-160	R 0,5	16		5	60	6	☑	
6JJCR-050-005-200		20		5	65	6	☑	
6JJCR-050-005-300		30		5	75	6	☑	
6JJCR-050-010-160	R 1	16	5	60	6	☑		
6JJCR-050-010-200		20	5	65	6	☑		
6JJCR-050-010-300		30	5	75	6	☑		
6JJCR-060-001-210	R 0,1	21	6	60	6	☑		
6JJCR-060-001-310		31	6	70	6	☑		
6JJCR-060-001-410		41	6	80	6	☑		
6JJCR-060-002-210	R 0,2	21	6	60	6	☑		
6JJCR-060-002-310		31	6	70	6	☑		
6JJCR-060-002-410		41	6	80	6	☑		
6JJCR-060-003-210	R 0,3	21	6	60	6	☑		
6JJCR-060-003-310		31	6	70	6	☑		
6JJCR-060-003-410		41	6	80	6	☑		
6JJCR-060-005-210	R 0,5	21	6	60	6	☑		
6JJCR-060-005-310		31	6	70	6	☑		

Objednací číslo	D (mm)	R (mm)	L2 (mm)	L1 (mm)	L (mm)	d h5 (mm)	Standardní položka
6JJCR-040-003-250	4	R 0,3	25	4	70	6	☑
6JJCR-040-003-300			30	4	75	6	☑
6JJCR-040-005-120			R 0,5	12	4	55	6
6JJCR-040-005-160		16		4	60	6	☑
6JJCR-040-005-200		20		4	65	6	☑
6JJCR-040-005-250		25		4	70	6	☑
6JJCR-040-005-300		30		4	75	6	☑
6JJCR-040-010-120		R 1		12	4	55	6
6JJCR-040-010-160			16	4	60	6	☑
6JJCR-040-010-200			20	4	65	6	☑
6JJCR-040-010-250		R 0,1	25	4	70	6	☑
6JJCR-040-010-300			30	4	75	6	☑
6JJCR-050-001-160			R 0,1	16	5	60	6
6JJCR-050-001-200		20		5	65	6	☑
6JJCR-050-001-300		30		5	75	6	☑
6JJCR-050-002-160		R 0,2	16	5	60	6	☑
6JJCR-050-002-200			20	5	65	6	☑
6JJCR-050-002-300			30	5	75	6	☑
6JJCR-050-003-160		R 0,3	16	5	60	6	☑
6JJCR-050-003-200			20	5	65	6	☑
6JJCR-050-003-300			30	5	75	6	☑
6JJCR-050-005-160		R 0,5	16	5	60	6	☑
6JJCR-050-005-200			20	5	65	6	☑
6JJCR-050-005-300			30	5	75	6	☑
6JJCR-050-010-160		R 1	16	5	60	6	☑
6JJCR-050-010-200			20	5	65	6	☑
6JJCR-050-010-300			30	5	75	6	☑
6JJCR-060-001-210		R 0,1	21	6	60	6	☑
6JJCR-060-001-310			31	6	70	6	☑
6JJCR-060-001-410			41	6	80	6	☑
6JJCR-060-002-210	R 0,2	21	6	60	6	☑	
6JJCR-060-002-310		31	6	70	6	☑	
6JJCR-060-002-410		41	6	80	6	☑	
6JJCR-060-003-210	R 0,3	21	6	60	6	☑	
6JJCR-060-003-310		31	6	70	6	☑	
6JJCR-060-003-410		41	6	80	6	☑	
6JJCR-060-005-210	R 0,5	21	6	60	6	☑	
6JJCR-060-005-310		31	6	70	6	☑	

NOVINKA

Objednací číslo	D (mm)	R (mm)	L2 (mm)	L1 (mm)	L (mm)	d h5 (mm)	Standardní položka	
6JJCR-060-005-410	6	R 0,5	41	6	80	6	<input checked="" type="checkbox"/>	
6JJCR-060-010-210		R 1	21	6	60	6	<input checked="" type="checkbox"/>	
6JJCR-060-010-310			31	6	70	6	<input checked="" type="checkbox"/>	
6JJCR-060-010-410			41	6	80	6	<input checked="" type="checkbox"/>	
6JJCR-080-003-260	8	R 0,3	26	8	70	8	<input checked="" type="checkbox"/>	
6JJCR-080-003-360			36	8	80	8	<input checked="" type="checkbox"/>	
6JJCR-080-003-460			46	8	90	8	<input checked="" type="checkbox"/>	
6JJCR-080-005-260		R 0,5	26	8	70	8	<input checked="" type="checkbox"/>	
6JJCR-080-005-360			36	8	80	8	<input checked="" type="checkbox"/>	
6JJCR-080-005-460			46	8	90	8	<input checked="" type="checkbox"/>	
6JJCR-080-010-260		R 1	26	8	70	8	<input checked="" type="checkbox"/>	
6JJCR-080-010-360			36	8	80	8	<input checked="" type="checkbox"/>	
6JJCR-080-010-460			46	8	90	8	<input checked="" type="checkbox"/>	
6JJCR-100-003-310			10	R 0,3	31	10	80	10
6JJCR-100-003-410		41			10	90	10	<input checked="" type="checkbox"/>
6JJCR-100-003-510		51			10	100	10	<input checked="" type="checkbox"/>
6JJCR-100-005-310	R 0,5	31		10	80	10	<input checked="" type="checkbox"/>	
6JJCR-100-005-410		41		10	90	10	<input checked="" type="checkbox"/>	
6JJCR-100-005-510		51		10	100	10	<input checked="" type="checkbox"/>	
6JJCR-100-010-310	R 1	31		10	80	10	<input checked="" type="checkbox"/>	
6JJCR-100-010-410		41		10	90	10	<input checked="" type="checkbox"/>	
6JJCR-100-010-510		51		10	100	10	<input checked="" type="checkbox"/>	
6JJCR-120-003-360	12	R 0,3		36	12	90	12	<input checked="" type="checkbox"/>
6JJCR-120-003-460				46	12	100	12	<input checked="" type="checkbox"/>
6JJCR-120-003-560				56	12	110	12	<input checked="" type="checkbox"/>
6JJCR-120-005-360		R 0,5	36	12	90	12	<input checked="" type="checkbox"/>	
6JJCR-120-005-460			46	12	100	12	<input checked="" type="checkbox"/>	
6JJCR-120-005-560			56	12	110	12	<input checked="" type="checkbox"/>	
6JJCR-120-010-360		R 1	36	12	90	12	<input checked="" type="checkbox"/>	
6JJCR-120-010-460			46	12	100	12	<input checked="" type="checkbox"/>	
6JJCR-120-010-560			56	12	110	12	<input checked="" type="checkbox"/>	

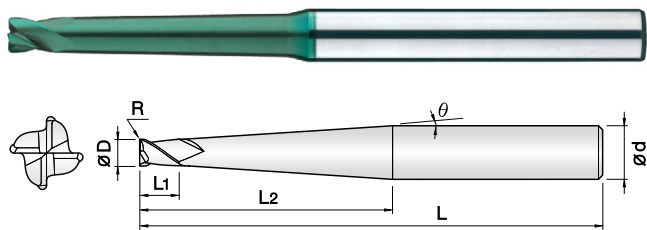

- **Určeno pro kalené oceli (52 - 68 HRC)**
- Vysoká odolnost proti opotřebení díky PVD povlaku na bázi Si
- Velmi přesné tolerance řezných hran
- Široký sortiment rádiusů a vložení pro optimální výběr nástroje
- Vysoká tuhost díky kuželovému odlehčení
- Vynikající výkon při vysokých řezných rychlostech díky 0,2 μm tvrdokovu

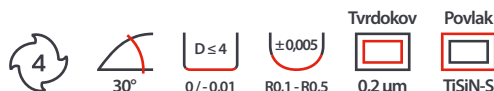

Objednáací číslo	D (mm)	R (mm)	Úhel θ	L2 (mm)	L1 (mm)	L (mm)	d h5 (mm)	Standardní položka	
4JJTC-010-001-0601	1	R 0,1	1°	6	1	50	4	☑	
4JJTC-010-001-1001			1°	10	1	50	4	☑	
4JJTC-010-001-1501			1°	15	1	50	4	☑	
4JJTC-010-001-2001			1°	20	1	60	4	☑	
4JJTC-010-001-2501			1°	25	1	60	4	☑	
4JJTC-010-001-3001			1°	30	1	70	4	☑	
4JJTC-010-001-3501			1°	35	1	75	4	☑	
4JJTC-010-002-0601			R 0,2	1°	6	1	50	4	☑
4JJTC-010-002-1001		1°		10	1	50	4	☑	
4JJTC-010-002-1501		1°		15	1	50	4	☑	
4JJTC-010-002-2001		1°		20	1	60	4	☑	
4JJTC-010-002-2501		1°		25	1	60	4	☑	
4JJTC-010-002-3001		1°		30	1	70	4	☑	
4JJTC-010-002-3501		1°		35	1	75	4	☑	
4JJTC-010-003-1001		R 0,3		1°	10	1	50	4	☑
4JJTC-010-003-1501			1°	15	1	50	4	☑	
4JJTC-010-003-2001			1°	20	1	60	4	☑	
4JJTC-010-003-2501			1°	25	1	60	4	☑	
4JJTC-015-002-1001		1,5	R 0,2	1°	10	1,5	50	4	☑
4JJTC-015-002-1501				1°	15	1,5	50	4	☑
4JJTC-015-002-2001	1°			20	1,5	60	4	☑	
4JJTC-015-002-2501	1°			25	1,5	60	4	☑	
4JJTC-015-002-3001	1°			30	1,5	70	4	☑	
4JJTC-015-002-3501	1°			35	1,5	75	4	☑	
4JJTC-015-003-1501	R 0,3		1°	15	1,5	50	4	☑	
4JJTC-015-003-2001			1°	20	1,5	60	4	☑	
4JJTC-015-003-2501			1°	25	1,5	60	4	☑	
4JJTC-015-005-1001			R 0,5	1°	10	1,5	50	4	☑
4JJTC-015-005-1501				1°	15	1,5	50	4	☑
4JJTC-015-005-2001				1°	20	1,5	60	4	☑
4JJTC-015-005-2501	1°	25		1,5	60	4	☑		
4JJTC-015-005-3001	1°	30		1,5	70	4	☑		
4JJTC-015-005-3501	1°	35		1,5	75	4	☑		
4JJTC-020-002-1201	2	R 0,2	1°	12	2	50	4	☑	
4JJTC-020-002-1601			1°	16	2	50	4	☑	
4JJTC-020-002-2001			1°	20	2	60	4	☑	
4JJTC-020-002-2501			1°	25	2	60	4	☑	
4JJTC-020-002-3001			1°	30	2	70	4	☑	
4JJTC-020-002-3501			1°	35	2	75	4	☑	

Objednáací číslo	D (mm)	R (mm)	Úhel θ	L2 (mm)	L1 (mm)	L (mm)	d h5 (mm)	Standardní položka	
4JJTC-020-002-4001	2	R 0,2	1°	40	2	80	4	☑	
4JJTC-020-002-5001			1°	50	2	90	4	☑	
4JJTC-020-003-2001			R 0,3	1°	20	2	60	4	☑
4JJTC-020-003-3001				1°	30	2	70	4	☑
4JJTC-020-003-4001		1°		40	2	80	4	☑	
4JJTC-020-005-1201		R 0,5		1°	12	2	50	4	☑
4JJTC-020-005-1601			1°	16	2	50	4	☑	
4JJTC-020-005-2001			1°	20	2	60	4	☑	
4JJTC-020-005-2501			1°	25	2	60	4	☑	
4JJTC-020-005-3001			1°	30	2	70	4	☑	
4JJTC-020-005-3501			1°	35	2	75	4	☑	
4JJTC-020-005-4001			1°	40	2	80	4	☑	
4JJTC-020-005-5001			1°	50	2	90	4	☑	
4JJTC-030-002-2001		3	R 0,2	1°	20	3	60	6	☑
4JJTC-030-002-3001				1°	30	3	70	6	☑
4JJTC-030-002-4001				1°	40	3	80	6	☑
4JJTC-030-002-5001				1°	50	3	90	6	☑
4JJTC-030-002-6001				1°	60	3	100	6	☑
4JJTC-030-003-4001				R 0,3	1°	40	3	80	6
4JJTC-030-003-5001			1°		50	3	90	6	☑
4JJTC-030-003-6001	1°		60		3	100	6	☑	
4JJTC-030-005-2001	R 0,5		1°		20	3	60	6	☑
4JJTC-030-005-3001			1°		30	3	70	6	☑
4JJTC-030-005-4001			1°		40	3	80	6	☑
4JJTC-030-005-5001			1°	50	3	90	6	☑	
4JJTC-030-005-6001		1°	60	3	100	6	☑		
4JJTC-040-002-2001		4	R 0,2	1°	20	4	60	6	☑
4JJTC-040-002-3001	1°			30	4	70	6	☑	
4JJTC-040-002-4001	1°			40	4	80	6	☑	
4JJTC-040-002-5001	1°			50	4	90	6	☑	
4JJTC-040-002-6001	1°			60	4	100	6	☑	
4JJTC-040-003-4001	R 0,3		1°	40	4	80	6	☑	
4JJTC-040-003-5001			1°	50	4	90	6	☑	
4JJTC-040-003-6001			1°	60	4	100	6	☑	
4JJTC-040-005-2001			R 0,5	1°	20	4	60	6	☑
4JJTC-040-005-3001				1°	30	4	70	6	☑
4JJTC-040-005-4001	1°	40		4	80	6	☑		
4JJTC-040-005-5001	1°	50		4	90	6	☑		
4JJTC-040-005-6001	1°	60		4	100	6	☑		

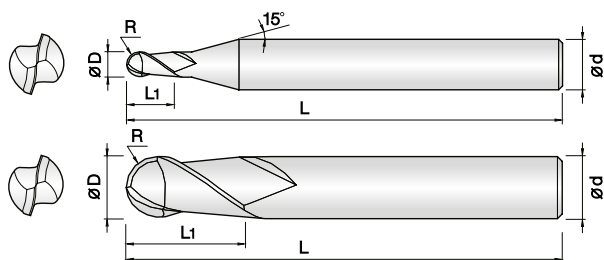

- Určeno pro kalené oceli (52–68 HRC)
- Vysoká odolnost proti opotřebení díky novému PVD povlaku s vysokým obsahem Si
- Velmi přesné tolerance řezných hran
- Vysoká tuhost
- Vynikající výkon při vysokých řezných rychlostech díky 0,2 μm tvrdokovu

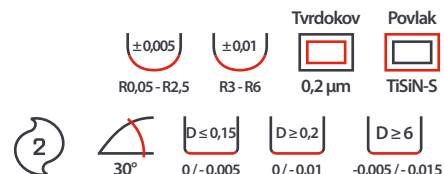

NOVINKA

Objednací číslo	D (mm)	R (mm)	L1 (mm)	L (mm)	d h5 (mm)	Standardní položka
2JJSB-001-001-S04	0,1	R 0,05	0,1	40	4	☑
2JJSB-001-0015-S04			0,15	40	4	☑
2JJSB-0015-0015-S04	0,15	R 0,075	0,15	40	4	☑
2JJSB-0015-002-S04			0,2	40	4	☑
2JJSB-002-002-S04	0,2	R 0,1	0,2	40	4	☑
2JJSB-002-003-S04			0,3	40	4	☑
2JJSB-003-003-S04	0,3	R 0,15	0,3	40	4	☑
2JJSB-003-0045-S04			0,45	40	4	☑
2JJSB-004-004-S04	0,4	R 0,2	0,4	40	4	☑
2JJSB-004-006-S04			0,6	40	4	☑
2JJSB-005-005-S04	0,5	R 0,25	0,5	40	4	☑
2JJSB-005-0075-S04			0,75	40	4	☑
2JJSB-006-006-S04	0,6	R 0,3	0,6	40	4	☑
2JJSB-006-009-S04			0,9	40	4	☑
2JJSB-007-007-S04	0,7	R 0,35	0,7	40	4	☑
2JJSB-007-010-S04			1	40	4	☑
2JJSB-008-008-S04	0,8	R 0,4	0,8	40	4	☑
2JJSB-008-012-S04			1,2	40	4	☑
2JJSB-009-009-S04	0,9	R 0,45	0,9	40	4	☑
2JJSB-009-013-S04			1,3	40	4	☑
2JJSB-010-010-S04	1	R 0,5	1	40	4	☑
2JJSB-010-010-S06			1	40	6	☑
2JJSB-010-015-S04			1,5	40	4	☑
2JJSB-010-015-S06			1,5	40	6	☑
2JJSB-012-012-S04	1,2	R 0,6	1,2	40	4	☑
2JJSB-015-015-S04	1,5	R 0,75	1,5	40	4	☑
2JJSB-015-015-S06			1,5	40	6	☑
2JJSB-015-023-S04			2,3	40	4	☑
2JJSB-015-023-S06			2,3	40	6	☑
2JJSB-020-020-S04	2	R 1	2	45	4	☑
2JJSB-020-020-S06			2	45	6	☑
2JJSB-020-030-S04			3	45	4	☑
2JJSB-020-030-S06			3	45	6	☑
2JJSB-025-025-S06	2,5	R 1,25	2,5	45	6	☑
2JJSB-030-030-S04	3	R 1,5	3	45	4	☑
2JJSB-030-030-S06			3	45	6	☑
2JJSB-030-045-S04			4,5	45	4	☑
2JJSB-030-045-S06			4,5	45	6	☑

Objednací číslo	D (mm)	R (mm)	L1 (mm)	L (mm)	d h5 (mm)	Standardní položka
2JJSB-040-040-S04	4	R 2	4	45	4	☑
2JJSB-040-040-S06			4	45	6	☑
2JJSB-040-060-S04			6	45	4	☑
2JJSB-040-060-S06			6	45	6	☑
2JJSB-050-050-S06	5	R 2,5	5	50	6	☑
2JJSB-050-075-S06			7,5	50	6	☑
2JJSB-060-060-050	6	R 3	6	50	6	☑
2JJSB-060-080-055			8	55	6	☑
2JJSB-080-080-050	8	R 4	8	50	8	☑
2JJSB-080-110-060			11	60	8	☑
2JJSB-100-100-060	10	R 5	10	60	10	☑
2JJSB-100-130-070			13	70	10	☑
2JJSB-120-120-060	12	R 6	12	60	12	☑
2JJSB-120-150-070			15	70	12	☑

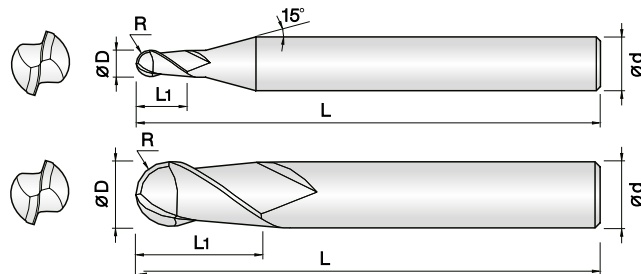

- **Určeno pro kalené oceli (52–68 HRC)**
- Vysoká odolnost proti opotřeбенí díky novému PVD povlaku s vysokým obsahem Si
- Velmi přesné tolerance řezných hran
- Vysoká kvalita obrobeného povrchu
- Vynikající výkon při vysokých řezných rychlostech díky 0,2 μm tvrdokovu

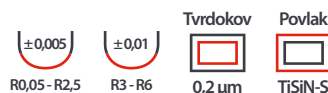
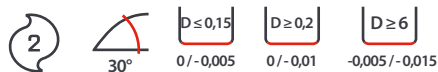

NOVINKA

Objednací číslo	D (mm)	R (mm)	L1 (mm)	L (mm)	d h5 (mm)	Standardní položka
2JJB-001-002-S04	0,1	R 0,05	0,2	40	4	☑
2JJB-0015-003-S04	0,15	R 0,075	0,3	40	4	☑
2JJB-002-004-S04	0,2	R 0,1	0,4	40	4	☑
2JJB-003-006-S04	0,3	R 0,15	0,6	40	4	☑
2JJB-004-008-S04	0,4	R 0,2	0,8	40	4	☑
2JJB-005-010-S04	0,5	R 0,25	1	45	4	☑
2JJB-006-012-S04	0,6	R 0,3	1,2	45	4	☑
2JJB-007-015-S04	0,7	R 0,35	1,5	45	4	☑
2JJB-008-020-S04	0,8	R 0,4	2	45	4	☑
2JJB-009-020-S04	0,9	R 0,45	2	45	4	☑
2JJB-010-025-S03	1	R 0,5	2,5	50	3	☑
2JJB-010-025-S04			2,5	50	4	☑
2JJB-010-025-S06	1	R 0,5	2,5	50	6	☑
2JJB-010-025-070			2,5	70	6	☑
2JJB-012-030-S03	1,2	R 0,6	3	50	3	☑
2JJB-012-030-S04			3	50	4	☑
2JJB-015-040-S03			4	50	3	☑
2JJB-015-040-S04	1,5	R 0,75	4	50	4	☑
2JJB-015-040-S06			4	50	6	☑
2JJB-015-040-070			4	70	6	☑
2JJB-020-050-S03			5	50	3	☑
2JJB-020-050-S04	2	R 1	5	50	4	☑
2JJB-020-050-S06			5	50	6	☑
2JJB-020-050-075			5	75	6	☑
2JJB-025-060-S03			6	50	3	☑
2JJB-025-060-S04	2,5	R 1,25	6	50	4	☑
2JJB-025-060-S06			6	75	6	☑
2JJB-030-080-S03			8	50	3	☑
2JJB-030-080-S04	3	R 1,5	8	50	4	☑
2JJB-030-080-S06			8	60	6	☑
2JJB-030-080-080			8	80	6	☑
2JJB-035-080-S06	3,5	R 1,75	8	60	6	☑
2JJB-040-080-S04			8	60	4	☑
2JJB-040-080-080	4	R 2	8	80	4	☑
2JJB-040-080-S06			8	70	6	☑
2JJB-040-080-090			8	90	6	☑
2JJB-045-080-S06	4,5	R 2,25	8	70	6	☑
2JJB-050-100-S06	5	R 2,5	10	75	6	☑

Objednací číslo	D (mm)	R (mm)	L1 (mm)	L (mm)	d h5 (mm)	Standardní položka
2JJB-055-100-S06	5,5	R 2,75	10	75	6	☑
2JJB-060-100-060			10	60	6	☑
2JJB-060-120-080	6	R 3	12	80	6	☑
2JJB-060-120-090			12	90	6	☑
2JJB-070-140-S08	7	R 3,5	14	80	8	☑
2JJB-080-120-060			12	60	8	☑
2JJB-080-140-090	8	R 4	14	90	8	☑
2JJB-080-140-100			14	100	8	☑
2JJB-100-150-070			15	70	10	☑
2JJB-100-180-100	10	R 5	18	100	10	☑
2JJB-120-180-075			18	75	12	☑
2JJB-120-220-110	12	R 6	22	110	12	☑
2JJB-140-240-110	14	R 7	24	110	14	☑

3JJB 3-břité KULOVÉ frézy pro kalené oceli do HRC 68

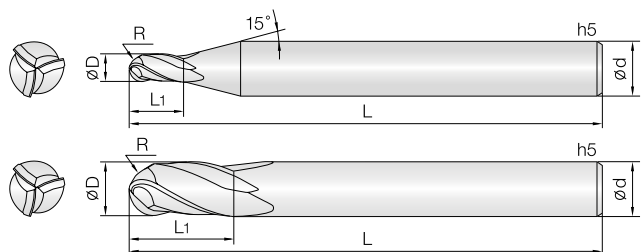

- Určeno pro kalené oceli (52–68 HRC)
- Vysoká odolnost proti opotřebení díky novému PVD povlaku s vysokým obsahem Si
- Velmi přesné tolerance řezných hran
- Vysoká produktivita obrábění díky třem břítům
- Vynikající výkon při vysokých řezných rychlostech díky 0,2 µm tvrdokovu

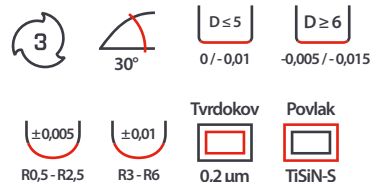

NOVINKA

Objednací číslo	D (mm)	R (mm)	L (mm)	L1 (mm)	d h5 (mm)	Standardní položka
3JJB-010-025-S04	1	R 0,5	50	2,5	4	☑
3JJB-012-030-S04	1,2	R 0,6	50	3	4	☑
3JJB-015-040-S04	1,5	R 0,75	50	4	4	☑
3JJB-020-050-S06	2	R 1	50	5	6	☑
3JJB-030-080-S06	3	R 1,5	65	8	6	☑
3JJB-040-080-S04	4	R 2	60	8	4	☑
3JJB-040-080-S06			70	8	6	☑
3JJB-050-100-S06	5	R 2,5	75	10	6	☑
3JJB-060-120-S06	6	R 3	80	12	6	☑
3JJB-060-120-120			120	12	6	☑
3JJB-080-140-S08	8	R 4	90	14	8	☑
3JJB-080-140-150			150	14	8	☑
3JJB-100-180-S10	10	R 5	100	18	10	☑
3JJB-100-180-150			150	18	10	☑
3JJB-120-220-S12	12	R 6	110	22	12	☑
3JJB-120-220-150			150	22	12	☑

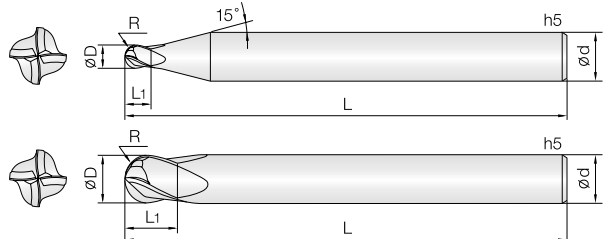

- **Určeno pro kalené oceli (52–68 HRC)**
- Vysoká odolnost proti opotřebení díky novému PVD povlaku s vysokým obsahem Si
- Velmi přesné tolerance řezných hran
- Krátká celková délka pro snadné použití se sklíčidlem
- Vysoká produktivita obrábění díky čtyřem břítům
- Vynikající výkon při vysokých řezných rychlostech díky 0,2 µm tvrdokovu

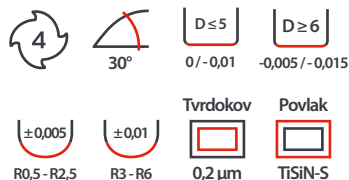

NOVINKA

Objednací číslo	D (mm)	R (mm)	L1 (mm)	L (mm)	d h5 (mm)	Standardní položka
4JJSB-010-012-S04	1	R 0,5	1,2	40	4	☑
4JJSB-012-015-S04	1,2	R 0,6	1,5	40	4	☑
4JJSB-015-018-S04	1,5	R 0,75	1,8	40	4	☑
4JJSB-020-024-S04	2	R 1	2,4	40	4	☑
4JJSB-025-030-S04	2,5	R 1,25	3	45	4	☑
4JJSB-030-036-S06	3	R 1,5	3,6	45	6	☑
4JJSB-040-050-S04	4	R 2	5	45	4	☑
4JJSB-040-050-S06			5	45	6	☑
4JJSB-050-060-S06	5	R 2,5	6	50	6	☑
4JJSB-060-070-S06	6	R 3	7	50	6	☑
4JJSB-060-070-060			7	60	6	☑
4JJSB-080-080-S08	8	R 4	8	60	8	☑
4JJSB-100-100-S10	10	R 5	10	60	10	☑
4JJSB-120-120-S12	12	R 6	12	75	12	☑

4JJB

4-břité KULOVÉ frézy pro kalené oceli do HRC 68

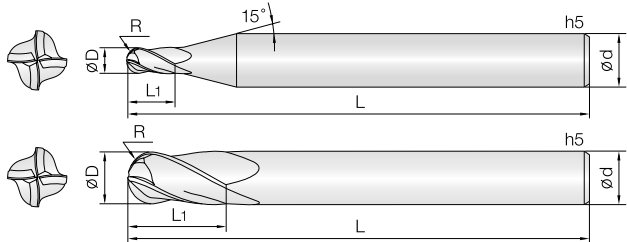

- **Určeno pro kalené oceli (52–68 HRC)**
- Vysoká odolnost proti opotřebení díky novému PVD povlaku s vysokým obsahem Si
- Velmi přesné tolerance řezných hran
- Vysoká produktivita obrábění díky čtyřem břítům
- Minimalizace vyštipování díky tvrdokovu s vysokou houževnatostí

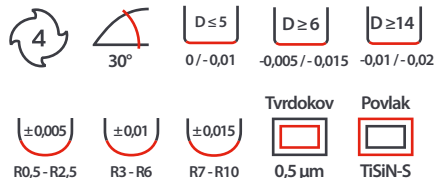

NOVINKA

Objednací číslo	D (mm)	R (mm)	L (mm)	L1 (mm)	d h5 (mm)	Standardní položka
4JJB-010-025-S06	1	R 0,5	50	2,5	6	<input checked="" type="checkbox"/>
4JJB-010-025-080			80	2,5	6	<input checked="" type="checkbox"/>
4JJB-012-030-S06	1,2	R 0,6	50	3	6	<input checked="" type="checkbox"/>
4JJB-015-040-S06	1,5	R 0,75	50	4	6	<input checked="" type="checkbox"/>
4JJB-015-040-080			80	4	6	<input checked="" type="checkbox"/>
4JJB-020-050-S06	2	R 1	50	5	6	<input checked="" type="checkbox"/>
4JJB-020-050-080			80	5	6	<input checked="" type="checkbox"/>
4JJB-025-070-S06	2,5	R 1,25	50	7	6	<input checked="" type="checkbox"/>
4JJB-025-070-080			80	7	6	<input checked="" type="checkbox"/>
4JJB-030-080-S06	3	R 1,5	60	8	6	<input checked="" type="checkbox"/>
4JJB-030-080-090			90	8	6	<input checked="" type="checkbox"/>
4JJB-040-080-S04	4	R 2	60	8	4	<input checked="" type="checkbox"/>
4JJB-040-080-090			90	8	4	<input checked="" type="checkbox"/>
4JJB-040-080-S06			70	8	6	<input checked="" type="checkbox"/>
4JJB-040-080-100			100	8	6	<input checked="" type="checkbox"/>
4JJB-050-100-S06	5	R 2,5	80	10	6	<input checked="" type="checkbox"/>
4JJB-050-100-110			110	10	6	<input checked="" type="checkbox"/>
4JJB-060-120-S06	6	R 3	90	12	6	<input checked="" type="checkbox"/>
4JJB-060-120-110			110	12	6	<input checked="" type="checkbox"/>
4JJB-080-140-S08	8	R 4	100	14	8	<input checked="" type="checkbox"/>
4JJB-080-140-150			150	14	8	<input checked="" type="checkbox"/>
4JJB-100-180-S10	10	R 5	100	18	10	<input checked="" type="checkbox"/>
4JJB-100-180-150			150	18	10	<input checked="" type="checkbox"/>
4JJB-120-220-S12	12	R 6	110	22	12	<input checked="" type="checkbox"/>
4JJB-120-220-150			150	22	12	<input checked="" type="checkbox"/>
4JJB-140-240-110	14	R 7	110	24	14	<input checked="" type="checkbox"/>
4JJB-160-300-S16	16	R 8	130	30	16	<input checked="" type="checkbox"/>
4JJB-160-300-160			160	30	16	<input checked="" type="checkbox"/>
4JJB-200-400-S20	20	R 10	160	40	20	<input checked="" type="checkbox"/>
4JJB-200-400-200			200	40	20	<input checked="" type="checkbox"/>

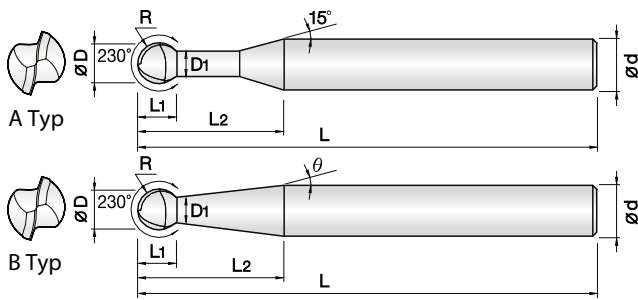

- ▶ **Určeno pro kalené oceli (52–68 HRC)**
- ▶ Vysoká odolnost proti opotřeбенí díky PVD povlaku na bázi Si
- ▶ Velmi přesné tolerance řezných hran
- ▶ 230° rádius pro vyšší rozsah 3D obrábění
- ▶ Vynikající výkon při vysokých řezných rychlostech díky 0,2 μm tvrdokovu

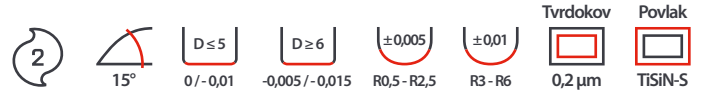

Objednací číslo	D (mm)	R (mm)	L2 (mm)	L1 (mm)	D1 (mm)	Úhel θ	L (mm)	d h5 (mm)	Typ	Standardní položka
2JJSP-010-040-S06	1	R 0,5	4	0,7	0,91	0°	60	6	A	<input checked="" type="checkbox"/>
2JJSP-010-060-S06			6	0,7	0,91	0°	60	6	A	<input checked="" type="checkbox"/>
2JJSP-010-013-200			20	0,7	0,91	1° 30'	80	6	B	<input checked="" type="checkbox"/>
2JJSP-015-060-S06	1,5	R 0,75	6	1	1,36	0°	60	6	A	<input checked="" type="checkbox"/>
2JJSP-015-080-S06			8	1	1,36	0°	60	6	A	<input checked="" type="checkbox"/>
2JJSP-015-013-200			20	1	1,36	1° 30'	80	6	B	<input checked="" type="checkbox"/>
2JJSP-020-060-S06	2	R 1	6	1,4	1,8	0°	60	6	A	<input checked="" type="checkbox"/>
2JJSP-020-100-S06			10	1,4	1,8	0°	60	6	A	<input checked="" type="checkbox"/>
2JJSP-020-013-200			20	1,4	1,8	1° 30'	80	6	B	<input checked="" type="checkbox"/>
2JJSP-030-100-S06	3	R 1,5	10	2,1	2,7	0°	70	6	A	<input checked="" type="checkbox"/>
2JJSP-030-150-S06			15	2,1	2,7	0°	70	6	A	<input checked="" type="checkbox"/>
2JJSP-030-013-300			30	2,1	2,7	1° 30'	80	6	B	<input checked="" type="checkbox"/>
2JJSP-040-120-S06	4	R 2	12	2,8	3,6	0°	70	6	A	<input checked="" type="checkbox"/>
2JJSP-040-200-S06			20	2,8	3,6	0°	70	6	A	<input checked="" type="checkbox"/>
2JJSP-040-030-250			25	2,8	3,6	3°	80	6	B	<input checked="" type="checkbox"/>
2JJSP-050-010-400	5	R 2,5	40	3,5	4,5	1°	90	6	B	<input checked="" type="checkbox"/>
2JJSP-060-150-S06	6	R 3	15	4,2	5,4	0°	90	6	A	<input checked="" type="checkbox"/>
2JJSP-060-300-S06			30	4,2	5,4	0°	90	6	A	<input checked="" type="checkbox"/>
2JJSP-060-010-210			21	4,2	5,4	1°	100	6	B	<input checked="" type="checkbox"/>
2JJSP-080-010-280	8	R 4	28	5,7	7,2	1°	100	8	B	<input checked="" type="checkbox"/>
2JJSP-100-010-350	10	R 5	35	7,1	9	1°	110	10	B	<input checked="" type="checkbox"/>
2JJSP-120-010-420	12	R 6	42	8,5	10,8	1°	120	12	B	<input checked="" type="checkbox"/>

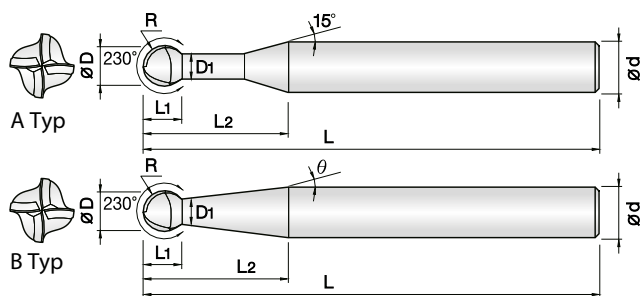

- ▶ **Určeno pro kalené oceli (52–68 HRC)**
- ▶ Vysoká odolnost proti opotřeбенí díky PVD povlaku na bázi Si
- ▶ Velmi přesné tolerance řezných hran
- ▶ 230° rádius pro vyšší rozsah 3D obrábění
- ▶ Vyšší posuvy díky 4 řezným hranám
- ▶ Vynikající výkon při vysokých řezných rychlostech díky 0,2 μm tvrdokovu

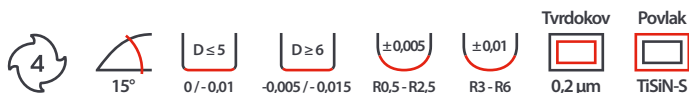

Objednací číslo	D (mm)	R (mm)	L2 (mm)	L1 (mm)	D1 (mm)	Úhel θ	L (mm)	d h5 (mm)	Typ	Standardní položka
4JJSP-010-040-506	1	R 0,5	4	0,7	0,91	0°	60	6	A	<input checked="" type="checkbox"/>
4JJSP-010-060-506			6	0,7	0,91	0°	60	6	A	<input checked="" type="checkbox"/>
4JJSP-010-013-200			20	0,7	0,91	1° 30'	80	6	B	<input checked="" type="checkbox"/>
4JJSP-015-060-506	1,5	R 0,75	6	1	1,36	0°	60	6	A	<input checked="" type="checkbox"/>
4JJSP-015-080-506			8	1	1,36	0°	60	6	A	<input checked="" type="checkbox"/>
4JJSP-015-013-200			20	1	1,36	1° 30'	80	6	B	<input checked="" type="checkbox"/>
4JJSP-020-060-506	2	R 1	6	1,4	1,8	0°	60	6	A	<input checked="" type="checkbox"/>
4JJSP-020-100-506			10	1,4	1,8	0°	60	6	A	<input checked="" type="checkbox"/>
4JJSP-020-013-200			20	1,4	1,8	1° 30'	80	6	B	<input checked="" type="checkbox"/>
4JJSP-030-100-506	3	R 1,5	10	2,1	2,7	0°	70	6	A	<input checked="" type="checkbox"/>
4JJSP-030-150-506			15	2,1	2,7	0°	70	6	A	<input checked="" type="checkbox"/>
4JJSP-030-013-300			30	2,1	2,7	1° 30'	80	6	B	<input checked="" type="checkbox"/>
4JJSP-040-120-506	4	R 2	12	2,8	3,6	0°	70	6	A	<input checked="" type="checkbox"/>
4JJSP-040-200-506			20	2,8	3,6	0°	70	6	A	<input checked="" type="checkbox"/>
4JJSP-040-030-250			25	2,8	3,6	3°	80	6	B	<input checked="" type="checkbox"/>
4JJSP-050-010-400	5	R 2,5	40	3,5	4,5	1°	90	6	B	<input checked="" type="checkbox"/>
4JJSP-060-150-506	6	R 3	15	4,2	5,4	0°	90	6	A	<input checked="" type="checkbox"/>
4JJSP-060-300-506			30	4,2	5,4	0°	90	6	A	<input checked="" type="checkbox"/>
4JJSP-060-010-210			21	4,2	5,4	1°	100	6	B	<input checked="" type="checkbox"/>
4JJSP-080-010-280	8	R 4	28	5,7	7,2	1°	100	8	B	<input checked="" type="checkbox"/>
4JJSP-100-010-350	10	R 5	35	7,1	9	1°	110	10	B	<input checked="" type="checkbox"/>
4JJSP-120-010-420	12	R 6	42	8,5	10,8	1°	120	12	B	<input checked="" type="checkbox"/>

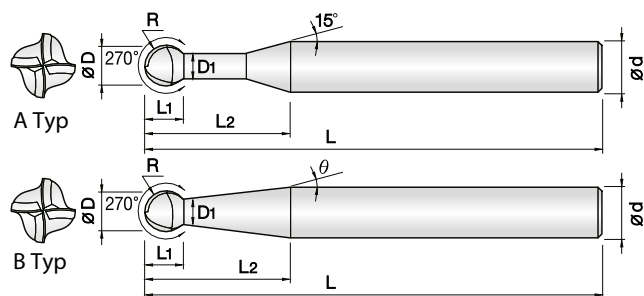

- ▶ **Určeno pro kalené oceli (52–68 HRC)**
- ▶ Vysoká odolnost proti opotřeбенí díky PVD povlaku na bázi Si
- ▶ Velmi přesné tolerance řezných hran
- ▶ 270° rádius pro vyšší rozsah 3D obrábění
- ▶ Vyšší posuvy díky 4 řezným hranám
- ▶ Vynikající výkon při vysokých řezných rychlostech díky 0,2 μm tvrdokovu

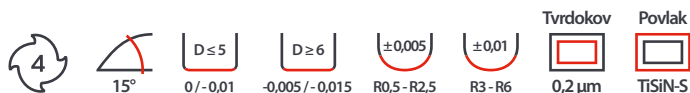

Objednací číslo	D (mm)	R (mm)	L2 (mm)	L1 (mm)	D1 (mm)	Úhel θ	L (mm)	d h5 (mm)	Typ	Standardní položka
4JJSPM-010-040-S06	1	R 0,5	4	0,8	0,7	0°	60	6	A	<input checked="" type="checkbox"/>
4JJSPM-010-060-S06			6	0,8	0,7	0°	60	6	A	<input checked="" type="checkbox"/>
4JJSPM-010-013-200			20	0,8	0,7	1° 30'	80	6	B	<input checked="" type="checkbox"/>
4JJSPM-015-060-S06	1,5	R 0,75	6	1,2	1	0°	60	6	A	<input checked="" type="checkbox"/>
4JJSPM-015-080-S06			8	1,2	1	0°	60	6	A	<input checked="" type="checkbox"/>
4JJSPM-015-013-200			20	1,2	1	1° 30'	80	6	B	<input checked="" type="checkbox"/>
4JJSPM-020-060-S06	2	R 1	6	1,7	1,4	0°	60	6	A	<input checked="" type="checkbox"/>
4JJSPM-020-100-S06			10	1,7	1,4	0°	60	6	A	<input checked="" type="checkbox"/>
4JJSPM-020-013-200			20	1,7	1,4	1° 30'	80	6	B	<input checked="" type="checkbox"/>
4JJSPM-030-100-S06	3	R 1,5	10	2,5	2,1	0°	70	6	A	<input checked="" type="checkbox"/>
4JJSPM-030-150-S06			15	2,5	2,1	0°	70	6	A	<input checked="" type="checkbox"/>
4JJSPM-030-013-300			30	2,5	2,1	1° 30'	80	6	B	<input checked="" type="checkbox"/>
4JJSPM-040-120-S06	4	R 2	12	3,4	2,8	0°	70	6	A	<input checked="" type="checkbox"/>
4JJSPM-040-200-S06			20	3,4	2,8	0°	70	6	A	<input checked="" type="checkbox"/>
4JJSPM-040-030-250			25	3,4	2,8	3°	80	6	B	<input checked="" type="checkbox"/>
4JJSPM-050-010-400	5	R 2,5	40	4,2	3,5	1°	90	6	B	<input checked="" type="checkbox"/>
4JJSPM-060-150-S06	6	R 3	15	5,1	4,2	0°	90	6	A	<input checked="" type="checkbox"/>
4JJSPM-060-300-S06			30	5,1	4,2	0°	90	6	A	<input checked="" type="checkbox"/>
4JJSPM-060-010-210			21	5,1	4,2	1°	100	6	B	<input checked="" type="checkbox"/>
4JJSPM-080-010-280	8	R 4	28	6,8	5,6	1°	100	8	B	<input checked="" type="checkbox"/>
4JJSPM-100-010-350	10	R 5	35	8,5	7	1°	110	10	B	<input checked="" type="checkbox"/>
4JJSPM-120-010-420	12	R 6	42	10	8,5	1°	120	12	B	<input checked="" type="checkbox"/>

2JJE 2-břité OSTRÉ frézy pro kalené oceli do HRC 65

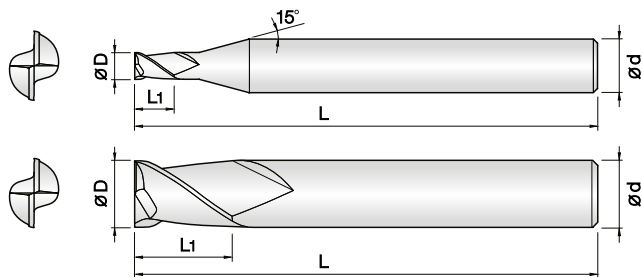

- Určeno pro kalené oceli (52–65 HRC)
- Vysoká odolnost proti opotřebování díky novému PVD povlaku s vysokým obsahem Si
- Velmi přesné tolerance řezných hran
- Minimalizace vyštipování díky zesílení řezné hrany
- Vynikající výkon při vysokých řezných rychlostech díky 0,2 μm tvrdokovu



NOVINKA

Objednací číslo	D (mm)	L1 (mm)	L (mm)	d h5 (mm)	Standardní položka
2JJE-0003-00045-S04	0,03	0,045	40	4	☑
2JJE-0004-0006-S04	0,04	0,06	40	4	☑
2JJE-0005-0008-S04	0,05	0,08	40	4	☑
2JJE-0006-001-S04	0,06	0,1	40	4	☑
2JJE-0007-0012-S04	0,07	0,12	40	4	☑
2JJE-0008-0015-S04	0,08	0,15	40	4	☑
2JJE-0009-0017-S04	0,09	0,17	40	4	☑
2JJE-001-002-S04	0,1	0,2	40	4	☑
2JJE-0015-003-S04	0,15	0,3	40	4	☑
2JJE-002-004-S04	0,2	0,4	40	4	☑
2JJE-0025-005-S04	0,25	0,5	40	4	☑
2JJE-003-006-S04	0,3	0,6	40	4	☑
2JJE-0035-007-S04	0,35	0,7	40	4	☑
2JJE-004-008-S04	0,4	0,8	40	4	☑
2JJE-0045-009-S04	0,45	0,9	40	4	☑
2JJE-005-010-S04	0,5	1	40	4	☑
2JJE-0055-011-S04	0,55	1,1	40	4	☑
2JJE-006-012-S04	0,6	1,2	40	4	☑
2JJE-0065-013-S04	0,65	1,3	40	4	☑
2JJE-007-014-S04	0,7	1,4	40	4	☑
2JJE-0075-015-S04	0,75	1,5	40	4	☑
2JJE-008-016-S04	0,8	1,6	40	4	☑
2JJE-0085-017-S04	0,85	1,7	40	4	☑
2JJE-009-020-S04	0,9	2	40	4	☑
2JJE-0095-020-S04	0,95	2	40	4	☑
2JJE-010-025-S03	1	2,5	40	3	☑
2JJE-010-025-S04	1	2,5	40	4	☑
2JJE-010-025-S06	1	2,5	40	6	☑
2JJE-011-027-S04	1,1	2,7	40	4	☑
2JJE-012-030-S03	1,2	3	40	3	☑
2JJE-012-030-S04	1,2	3	40	4	☑
2JJE-013-032-S04	1,3	3,2	40	4	☑
2JJE-014-035-S04	1,4	3,5	40	4	☑
2JJE-015-040-S03	1,5	4	40	3	☑
2JJE-015-040-S04	1,5	4	40	4	☑
2JJE-015-040-S06	1,5	4	40	6	☑
2JJE-016-040-S04	1,6	4	40	4	☑
2JJE-017-042-S04	1,7	4,2	40	4	☑
2JJE-018-045-S04	1,8	4,5	40	4	☑
2JJE-019-050-S04	1,9	5	40	4	☑
2JJE-020-060-S03	2	6	40	3	☑

Objednací číslo	D (mm)	L1 (mm)	L (mm)	d h5 (mm)	Standardní položka
2JJE-020-060-S04	2	6	40	4	☑
2JJE-020-060-S06	2	6	40	6	☑
2JJE-021-060-S04	2,1	6	40	4	☑
2JJE-022-060-S04	2,2	6	40	4	☑
2JJE-023-060-S04	2,3	6	40	4	☑
2JJE-024-080-S04	2,4	8	45	4	☑
2JJE-025-080-S03	2,5	8	45	3	☑
2JJE-025-080-S04	2,5	8	45	4	☑
2JJE-025-080-S06	2,5	8	45	6	☑
2JJE-026-080-S04	2,6	8	45	4	☑
2JJE-027-080-S04	2,7	8	45	4	☑
2JJE-028-080-S04	2,8	8	45	4	☑
2JJE-029-080-S04	2,9	8	45	4	☑
2JJE-030-080-S03	3	8	50	3	☑
2JJE-030-080-S04	3	8	45	4	☑
2JJE-030-080-S06	3	8	45	6	☑
2JJE-035-100-S06	3,5	10	45	6	☑
2JJE-040-100-S04	4	10	45	4	☑
2JJE-040-110-S06	4	11	45	6	☑
2JJE-045-110-S06	4,5	11	45	6	☑
2JJE-050-130-S06	5	13	50	6	☑
2JJE-055-130-S06	5,5	13	50	6	☑
2JJE-060-130-S06	6	13	50	6	☑
2JJE-065-160-S08	6,5	16	60	8	☑
2JJE-070-160-S08	7	16	60	8	☑
2JJE-075-160-S08	7,5	16	60	8	☑
2JJE-080-190-S08	8	19	60	8	☑
2JJE-085-190-S10	8,5	19	70	10	☑
2JJE-090-190-S10	9	19	70	10	☑
2JJE-095-190-S10	9,5	19	70	10	☑
2JJE-100-220-S10	10	22	70	10	☑
2JJE-105-220-S12	10,5	22	75	12	☑
2JJE-110-220-S12	11	22	75	12	☑
2JJE-115-220-S12	11,5	22	75	12	☑
2JJE-120-260-S12	12	26	75	12	☑
2JJE-140-260-S14	14	26	80	14	☑
2JJE-140-260-S16	14	26	90	16	☑
2JJE-160-350-S16	16	35	100	16	☑
2JJE-180-350-S18	18	35	100	18	☑
2JJE-200-400-S20	20	40	100	20	☑

4JJE 4-břité OSTRÉ frézy pro kalené oceli do HRC 65

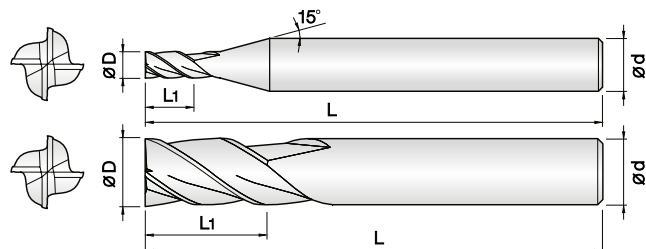

- ▶ **Určeno pro kalené oceli (52–65 HRC)**
- ▶ Vysoká odolnost proti opotřeбенí díky novému PVD povlaku s vysokým obsahem Si
- ▶ Velmi přesné tolerance řezných hran
- ▶ Minimalizace vyštipování díky zesílení řezné hrany
- ▶ Vynikající výkon při vysokých řezných rychlostech díky 0,2 μm tvrdkovu



NOVINKA

Objednací číslo	D (mm)	L1 (mm)	L (mm)	d h5 (mm)	Standardní položka
4JJE-003-006-S04	0,3	0,6	40	4	☑
4JJE-004-008-S04	0,4	0,8	40	4	☑
4JJE-005-010-S04	0,5	1	40	4	☑
4JJE-006-012-S04	0,6	1,2	40	4	☑
4JJE-007-014-S04	0,7	1,4	40	4	☑
4JJE-008-016-S04	0,8	1,6	40	4	☑
4JJE-009-018-S04	0,9	1,8	40	4	☑
4JJE-010-025-S03	1	2,5	40	3	☑
4JJE-010-025-S04	1	2,5	40	4	☑
4JJE-010-025-S06	1	2,5	40	6	☑
4JJE-012-030-S03	1,2	3	40	3	☑
4JJE-012-030-S04	1,2	3	40	4	☑
4JJE-015-040-S03	1,5	4	40	3	☑
4JJE-015-040-S04	1,5	4	40	4	☑
4JJE-015-040-S06	1,5	4	40	6	☑
4JJE-020-060-S03	2	6	40	3	☑
4JJE-020-060-S04	2	6	40	4	☑
4JJE-020-060-S06	2	6	40	6	☑
4JJE-025-080-S03	2,5	8	45	3	☑
4JJE-025-080-S04	2,5	8	45	4	☑
4JJE-025-080-S06	2,5	8	45	6	☑
4JJE-030-080-S03	3	8	50	3	☑
4JJE-030-080-S04	3	8	45	4	☑
4JJE-030-080-S06	3	8	45	6	☑
4JJE-035-100-S06	3,5	10	45	6	☑
4JJE-040-110-S04	4	11	45	4	☑
4JJE-040-110-S06	4	11	45	6	☑
4JJE-045-110-S06	4,5	11	45	6	☑
4JJE-050-130-S06	5	13	50	6	☑
4JJE-055-130-S06	5,5	13	50	6	☑
4JJE-060-130-S06	6	13	50	6	☑
4JJE-080-190-S08	8	19	60	8	☑
4JJE-100-220-S10	10	22	70	10	☑
4JJE-120-260-S12	12	26	75	12	☑
4JJE-140-300-S14	14	30	90	14	☑
4JJE-160-350-S16	16	35	100	16	☑
4JJE-200-400-S20	20	40	100	20	☑

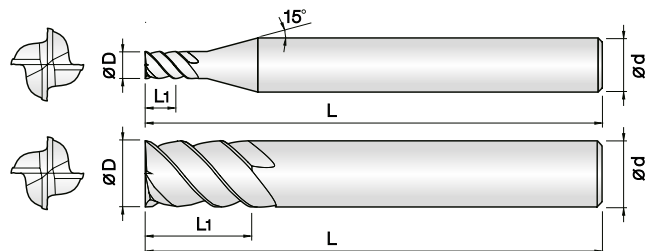

- ▶ **Určeno pro kalené oceli (52–65 HRC)**
- ▶ Vysoká odolnost proti opotřeбенí díky novému PVD povlaku s vysokým obsahem Si
- ▶ Velmi přesné tolerance řezných hran
- ▶ Minimalizace vyštipování díky zesílení řezné hrany
- ▶ Vyšší posuvy díky 45° geometrii
- ▶ Vynikající výkon při vysokých řezných rychlostech díky 0,2 μm tvrdokovu

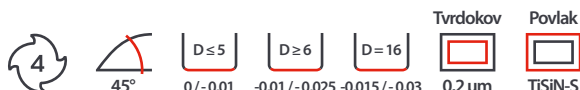

Objednací číslo	D (mm)	L1 (mm)	L (mm)	d h5 (mm)	Standardní položka
4JJHE-010-015-S06	1	1,5	40	6	☑
4JJHE-010-025-S06		2,5	40	6	☑
4JJHE-010-035-S06		3,5	40	6	☑
4JJHE-010-050-S06		5	45	6	☑
4JJHE-015-040-S06		1,5	4	40	6
4JJHE-015-060-S06	6		40	6	☑
4JJHE-015-080-S06	8		40	6	☑
4JJHE-020-030-S06	2	3	40	6	☑
4JJHE-020-050-S06		5	40	6	☑
4JJHE-020-080-S06		8	40	6	☑
4JJHE-020-100-S06		10	45	6	☑
4JJHE-025-060-S06	2,5	6	45	6	☑
4JJHE-025-080-S06		8	45	6	☑
4JJHE-025-100-S06		10	50	6	☑
4JJHE-030-060-S06	3	6	45	6	☑
4JJHE-030-080-S06		8	45	6	☑
4JJHE-030-120-S06		12	50	6	☑
4JJHE-030-150-S06		15	50	6	☑
4JJHE-035-080-S06	3,5	8	45	6	☑
4JJHE-040-080-S06	4	8	45	6	☑
4JJHE-040-110-S06		11	45	6	☑
4JJHE-040-150-S06		15	55	6	☑
4JJHE-040-200-S06	4,5	20	60	6	☑
4JJHE-045-110-S06		11	50	6	☑
4JJHE-050-100-S06	5	10	50	6	☑
4JJHE-050-130-S06		13	50	6	☑
4JJHE-050-200-S06		20	60	6	☑
4JJHE-050-250-S06		25	70	6	☑
4JJHE-050-300-S06	6	30	75	6	☑
4JJHE-060-130-S06		13	50	6	☑
4JJHE-060-150-S06		15	55	6	☑
4JJHE-060-200-S06	6	20	60	6	☑
4JJHE-060-250-S06		25	70	6	☑
4JJHE-060-300-S06		30	75	6	☑
4JJHE-070-160-S08	7	16	60	8	☑
4JJHE-080-200-S08	8	20	60	8	☑
4JJHE-080-250-S08		25	70	8	☑
4JJHE-080-300-S08		30	80	8	☑

Objednací číslo	D (mm)	L1 (mm)	L (mm)	d h5 (mm)	Standardní položka
4JJHE-080-400-S08	8	40	90	8	☑
4JJHE-090-220-S10	9	22	70	10	☑
4JJHE-100-220-S10	10	22	70	10	☑
4JJHE-100-300-S10		30	80	10	☑
4JJHE-100-400-S10		40	90	10	☑
4JJHE-100-500-S10	12	50	100	10	☑
4JJHE-120-260-S12		26	75	12	☑
4JJHE-120-350-S12		35	90	12	☑
4JJHE-120-500-S12		50	100	12	☑
4JJHE-120-600-S12	14	60	110	12	☑
4JJHE-140-350-S14		35	90	14	☑
4JJHE-140-550-S14	16	55	110	14	☑
4JJHE-160-350-S16		35	90	16	☑
4JJHE-160-500-S16		50	110	16	☑
4JJHE-160-700-S16	18	70	130	16	☑
4JJHE-180-380-S18		38	100	18	☑
4JJHE-200-400-S20	20	40	100	20	☑
4JJHE-200-550-S20		55	120	20	☑
4JJHE-200-750-S20		75	150	20	☑

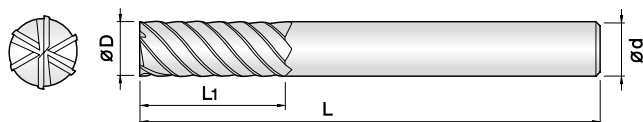

- ▶ **Určeno pro kalené oceli (52–68 HRC)**
- ▶ Vysoká odolnost proti opotřebení díky novému PVD povlaku s vysokým obsahem Si
- ▶ Velmi přesné tolerance řezných hran
- ▶ Minimalizace vyštipování díky zesílení řezné hrany
- ▶ Vyšší posuvy díky 45° geometrii
- ▶ Vynikající výkon při vysokých řezných rychlostech díky 0,2 μm tvrdokovu



NOVINKA

Objednací číslo	D (mm)	L1 (mm)	L (mm)	d h5 (mm)	Standardní položka
6JJHE-030-100-S06	3	10	50	6	☑
6JJHE-030-150-S06		15	50	6	☑
6JJHE-030-200-S06		20	60	6	☑
6JJHE-040-120-S06	4	12	50	6	☑
6JJHE-040-160-S06		16	50	6	☑
6JJHE-040-200-S06		20	60	6	☑
6JJHE-050-150-S06	5	15	50	6	☑
6JJHE-050-200-S06		20	60	6	☑
6JJHE-050-250-S06		25	60	6	☑
6JJHE-060-150-S06	6	15	50	6	☑
6JJHE-060-200-S06		20	60	6	☑
6JJHE-060-250-S06		25	65	6	☑
6JJHE-060-300-S06		30	70	6	☑
6JJHE-060-350-S06		35	75	6	☑
6JJHE-060-400-S06		40	80	6	☑
6JJHE-080-200-S08	8	20	60	8	☑
6JJHE-080-250-S08		25	65	8	☑
6JJHE-080-300-S08		30	75	8	☑
6JJHE-080-350-S08		35	80	8	☑
6JJHE-080-400-S08		40	90	8	☑
6JJHE-080-450-S08		45	100	8	☑
6JJHE-080-500-S08	10	50	100	8	☑
6JJHE-100-250-S10		25	70	10	☑
6JJHE-100-350-S10		35	90	10	☑
6JJHE-100-450-S10		45	100	10	☑
6JJHE-100-500-S10		50	100	10	☑
6JJHE-100-600-S10		60	110	10	☑
6JJHE-120-300-S12	12	30	80	12	☑
6JJHE-120-400-S12		40	90	12	☑
6JJHE-120-500-S12		50	100	12	☑
6JJHE-120-600-S12		60	110	12	☑
6JJHE-120-700-S12		70	120	12	☑
6JJHE-140-350-S14	14	35	90	14	☑
6JJHE-140-550-S14		55	110	14	☑
6JJHE-140-750-S14		75	150	14	☑
6JJHE-160-350-S16	16	35	90	16	☑
6JJHE-160-500-S16		50	110	16	☑
6JJHE-160-650-S16		65	120	16	☑

Objednací číslo	D (mm)	L1 (mm)	L (mm)	d h5 (mm)	Standardní položka
6JJHE-160-800-S16	16	80	150	16	☑
6JJHE-160-900-S16		90	160	16	☑
6JJHE-160-1000-S16		100	160	16	☑
6JJHE-180-400-S18	18	40	100	18	☑
6JJHE-180-650-S18		65	120	18	☑
6JJHE-200-450-S20	20	45	100	20	☑
6JJHE-200-600-S20		60	120	20	☑
6JJHE-200-800-S20		80	150	20	☑
6JJHE-200-900-S20		90	160	20	☑
6JJHE-200-1000-S20		100	160	20	☑
6JJHE-200-1100-S20		110	170	20	☑
6JJHE-200-1200-S20		120	180	20	☑
8JJHE-250-1000-S25	25	100	160	25	☑
8JJHE-250-1300-S25		130	200	25	☑

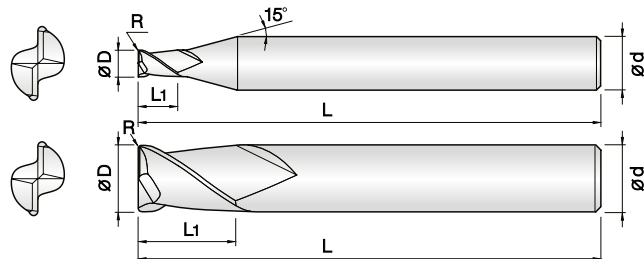

- Určeno pro kalené oceli (52–68 HRC)
- Vysoká odolnost proti opotřeby díky novému PVD povlaku s vysokým obsahem Si
- Velmi přesné tolerance řezných hran
- Široký sortiment rádiusů a délek pro optimální výběr nástroje
- Vynikající výkon při vysokých řezných rychlostech díky 0,2 μm tvrdokovu

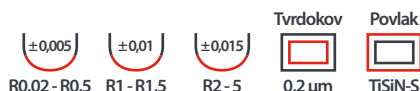
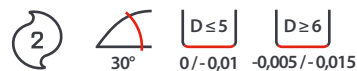

NOVINKA

Objednací číslo	D (mm)	R (mm)	L1 (mm)	L (mm)	d h5 (mm)	Standardní položka
2JJC-002-0002-S04	0,2	R 0,02	0,4	45	4	☑
2JJC-002-0005-S04		R 0,05	0,4	45	4	☑
2JJC-003-0002-S04	0,3	R 0,02	0,6	45	4	☑
2JJC-003-0005-S04		R 0,05	0,6	45	4	☑
2JJC-003-001-S04		R 0,1	0,6	45	4	☑
2JJC-004-0002-S04	0,4	R 0,02	0,8	45	4	☑
2JJC-004-0005-S04		R 0,05	0,8	45	4	☑
2JJC-004-001-S04		R 0,1	0,8	45	4	☑
2JJC-005-0002-S04	0,5	R 0,02	1	45	4	☑
2JJC-005-0005-S04		R 0,05	1	45	4	☑
2JJC-005-001-S04		R 0,1	1	45	4	☑
2JJC-006-0002-S04	0,6	R 0,02	1,2	45	4	☑
2JJC-006-0005-S04		R 0,05	1,2	45	4	☑
2JJC-006-001-S04		R 0,1	1,2	45	4	☑
2JJC-006-002-S04	0,7	R 0,2	1,2	45	4	☑
2JJC-007-0005-S04		R 0,05	1,4	45	4	☑
2JJC-007-001-S04		R 0,1	1,4	45	4	☑
2JJC-007-002-S04	0,8	R 0,2	1,4	45	4	☑
2JJC-008-0002-S04		R 0,02	1,6	45	4	☑
2JJC-008-0005-S04		R 0,05	1,6	45	4	☑
2JJC-008-001-S04		R 0,1	1,6	45	4	☑
2JJC-008-002-S04	0,9	R 0,2	1,6	45	4	☑
2JJC-009-0005-S04		R 0,05	1,8	45	4	☑
2JJC-009-001-S04		R 0,1	1,8	45	4	☑
2JJC-010-0002-S04	1	R 0,02	2,5	45	4	☑
2JJC-010-0005-S04		R 0,05	2,5	45	4	☑
2JJC-010-001-S04		R 0,1	2,5	45	4	☑
2JJC-010-002-S04		R 0,2	2,5	45	4	☑
2JJC-010-003-S04	1,2	R 0,3	2,5	45	4	☑
2JJC-012-0002-S04		R 0,02	3,2	45	4	☑
2JJC-012-0005-S04		R 0,05	3,2	45	4	☑
2JJC-012-001-S04	1,5	R 0,1	3,2	45	4	☑
2JJC-012-002-S04		R 0,2	3,2	45	4	☑
2JJC-012-003-S04		R 0,3	3,2	45	4	☑
2JJC-015-0002-S04	1,5	R 0,02	4	45	4	☑
2JJC-015-0005-S04		R 0,05	4	45	4	☑
2JJC-015-001-S04		R 0,1	4	45	4	☑
2JJC-015-002-S04		R 0,2	4	45	4	☑

Objednací číslo	D (mm)	R (mm)	L1 (mm)	L (mm)	d h5 (mm)	Standardní položka
2JJC-015-003-S04	1,5	R 0,3	4	45	4	☑
2JJC-015-005-S04		R 0,5	4	45	4	☑
2JJC-020-0002-S04	2	R 0,02	6	45	4	☑
2JJC-020-0005-S04		R 0,05	6	45	4	☑
2JJC-020-001-S04		R 0,1	6	45	4	☑
2JJC-020-002-S04		R 0,2	6	45	4	☑
2JJC-020-003-S04	2,5	R 0,3	6	45	4	☑
2JJC-020-005-S04		R 0,5	6	45	4	☑
2JJC-025-001-S04		R 0,1	6	50	4	☑
2JJC-025-002-S04	3	R 0,2	6	50	4	☑
2JJC-025-003-S04		R 0,3	6	50	4	☑
2JJC-025-005-S04		R 0,5	6	50	4	☑
2JJC-030-001-S06	3	R 0,1	8	60	6	☑
2JJC-030-002-S06		R 0,2	8	60	6	☑
2JJC-030-003-S06		R 0,3	8	60	6	☑
2JJC-030-005-S06		R 0,5	8	60	6	☑
2JJC-030-010-S06	4	R 1	8	60	6	☑
2JJC-040-001-S04		R 0,1	9	60	4	☑
2JJC-040-001-S06		R 0,2	10	70	6	☑
2JJC-040-002-S04			9	60	4	☑
2JJC-040-002-S06		R 0,3	10	70	6	☑
2JJC-040-003-S04			9	60	4	☑
2JJC-040-003-S06		R 0,5	10	70	6	☑
2JJC-040-005-S04			9	60	4	☑
2JJC-040-005-S06	5	10	70	6	☑	
2JJC-040-010-S04		R 1	9	60	4	☑
2JJC-040-010-S06		R 0,1	10	70	6	☑
2JJC-050-001-S06			13	75	6	☑
2JJC-050-002-S06	R 0,2	13	75	6	☑	
2JJC-050-003-S06		13	75	6	☑	
2JJC-050-005-S06		13	75	6	☑	
2JJC-050-010-S06	6	R 1	13	75	6	☑
2JJC-060-001-060		R 0,1	11	60	6	☑
2JJC-060-001-090			13	90	6	☑
2JJC-060-002-060		R 0,2	11	60	6	☑
2JJC-060-002-090			13	90	6	☑
2JJC-060-003-060		R 0,3	11	60	6	☑
2JJC-060-003-090	13		90	6	☑	

Objednáací číslo	D (mm)	R (mm)	L1 (mm)	L (mm)	d h5 (mm)	Standardní položka	
2JJC-060-005-060	6	R 0,5	11	60	6	<input checked="" type="checkbox"/>	
2JJC-060-005-090			13	90	6	<input checked="" type="checkbox"/>	
2JJC-060-005-110			13	110	6	<input checked="" type="checkbox"/>	
2JJC-060-010-060		R 1	11	60	6	<input checked="" type="checkbox"/>	
2JJC-060-010-090			13	90	6	<input checked="" type="checkbox"/>	
2JJC-060-010-110			13	110	6	<input checked="" type="checkbox"/>	
2JJC-060-015-060		R 1,5	11	60	6	<input checked="" type="checkbox"/>	
2JJC-060-015-090			13	90	6	<input checked="" type="checkbox"/>	
2JJC-060-020-060		R 2	11	60	6	<input checked="" type="checkbox"/>	
2JJC-060-020-090			13	90	6	<input checked="" type="checkbox"/>	
2JJC-060-025-090		R 2,5	13	90	6	<input checked="" type="checkbox"/>	
2JJC-080-001-070		8	R 0,1	16	70	8	<input checked="" type="checkbox"/>
2JJC-080-001-100				19	100	8	<input checked="" type="checkbox"/>
2JJC-080-002-070			R 0,2	16	70	8	<input checked="" type="checkbox"/>
2JJC-080-002-100	19			100	8	<input checked="" type="checkbox"/>	
2JJC-080-003-070	R 0,3		16	70	8	<input checked="" type="checkbox"/>	
2JJC-080-003-100			19	100	8	<input checked="" type="checkbox"/>	
2JJC-080-005-070	R 0,5		16	70	8	<input checked="" type="checkbox"/>	
2JJC-080-005-100			19	100	8	<input checked="" type="checkbox"/>	
2JJC-080-005-120			19	120	8	<input checked="" type="checkbox"/>	
2JJC-080-010-070	R 1		16	70	8	<input checked="" type="checkbox"/>	
2JJC-080-010-100			19	100	8	<input checked="" type="checkbox"/>	
2JJC-080-010-120			19	120	8	<input checked="" type="checkbox"/>	
2JJC-080-015-070			R 1,5	16	70	8	<input checked="" type="checkbox"/>
2JJC-080-015-100	19			100	8	<input checked="" type="checkbox"/>	
2JJC-080-020-070	R 2	16	70	8	<input checked="" type="checkbox"/>		
2JJC-080-020-100		19	100	8	<input checked="" type="checkbox"/>		
2JJC-080-025-100	R 2,5	19	100	8	<input checked="" type="checkbox"/>		
2JJC-080-030-100	R 3	19	100	8	<input checked="" type="checkbox"/>		
2JJC-080-035-100	R 3,5	19	100	8	<input checked="" type="checkbox"/>		
2JJC-100-001-075	10	R 0,1	19	75	10	<input checked="" type="checkbox"/>	
2JJC-100-001-100			22	100	10	<input checked="" type="checkbox"/>	
2JJC-100-002-075		R 0,2	19	75	10	<input checked="" type="checkbox"/>	
2JJC-100-002-100			22	100	10	<input checked="" type="checkbox"/>	
2JJC-100-003-075		R 0,3	19	75	10	<input checked="" type="checkbox"/>	
2JJC-100-003-100			22	100	10	<input checked="" type="checkbox"/>	
2JJC-100-005-075		R 0,5	19	75	10	<input checked="" type="checkbox"/>	
2JJC-100-005-100			22	100	10	<input checked="" type="checkbox"/>	
2JJC-100-005-120			22	120	10	<input checked="" type="checkbox"/>	
2JJC-100-010-075		R 1	19	75	10	<input checked="" type="checkbox"/>	
2JJC-100-010-100			22	100	10	<input checked="" type="checkbox"/>	
2JJC-100-010-120			22	120	10	<input checked="" type="checkbox"/>	
2JJC-100-015-075		R 1,5	19	75	10	<input checked="" type="checkbox"/>	
2JJC-100-015-100			22	100	10	<input checked="" type="checkbox"/>	
2JJC-100-020-075	R 2	19	75	10	<input checked="" type="checkbox"/>		
2JJC-100-020-100		22	100	10	<input checked="" type="checkbox"/>		
2JJC-100-025-100	R 2,5	22	100	10	<input checked="" type="checkbox"/>		
2JJC-100-030-100	R 3	22	100	10	<input checked="" type="checkbox"/>		
2JJC-100-040-100	R 4	22	100	10	<input checked="" type="checkbox"/>		
2JJC-120-001-080	12	R 0,1	22	80	12	<input checked="" type="checkbox"/>	
2JJC-120-001-110			26	110	12	<input checked="" type="checkbox"/>	
2JJC-120-002-080		R 0,2	22	80	12	<input checked="" type="checkbox"/>	

Objednáací číslo	D (mm)	R (mm)	L1 (mm)	L (mm)	d h5 (mm)	Standardní položka
2JJC-120-002-110	12	R 0,2	26	110	12	<input checked="" type="checkbox"/>
2JJC-120-003-080		R 0,3	22	80	12	<input checked="" type="checkbox"/>
2JJC-120-003-110			26	110	12	<input checked="" type="checkbox"/>
2JJC-120-005-080		R 0,5	22	80	12	<input checked="" type="checkbox"/>
2JJC-120-005-110			26	110	12	<input checked="" type="checkbox"/>
2JJC-120-005-130			26	130	12	<input checked="" type="checkbox"/>
2JJC-120-010-080		R 1	22	80	12	<input checked="" type="checkbox"/>
2JJC-120-010-110			26	110	12	<input checked="" type="checkbox"/>
2JJC-120-010-130			26	130	12	<input checked="" type="checkbox"/>
2JJC-120-015-080		R 1,5	22	80	12	<input checked="" type="checkbox"/>
2JJC-120-015-110			26	110	12	<input checked="" type="checkbox"/>
2JJC-120-020-080		R 2	22	80	12	<input checked="" type="checkbox"/>
2JJC-120-020-110			26	110	12	<input checked="" type="checkbox"/>
2JJC-120-020-130			26	130	12	<input checked="" type="checkbox"/>
2JJC-120-025-110	R 2,5	26	110	12	<input checked="" type="checkbox"/>	
2JJC-120-030-110	R 3	26	110	12	<input checked="" type="checkbox"/>	
2JJC-120-040-110	R 4	26	110	12	<input checked="" type="checkbox"/>	
2JJC-120-050-110	R 5	26	110	12	<input checked="" type="checkbox"/>	
2JJC-140-005-110	14	R 0,5	30	110	14	<input checked="" type="checkbox"/>
2JJC-140-010-110		R 1	30	110	14	<input checked="" type="checkbox"/>
2JJC-140-020-110		R 2	30	110	14	<input checked="" type="checkbox"/>

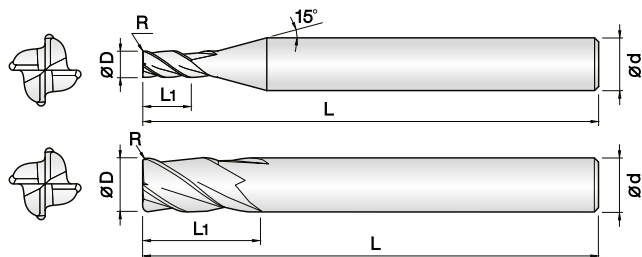

- ▶ **Určeno pro kalené oceli (52–68 HRC)**
- ▶ Vysoká odolnost proti opotřebování díky novému PVD povlaku s vysokým obsahem Si
- ▶ 45° šroubovice pro vysokorychlostní posuv
- ▶ Široký sortiment rádiusů a délek pro optimální výběr nástroje
- ▶ Vynikající výkon při vysokých rezných rychlostech díky 0,2 μm tvrdokovu

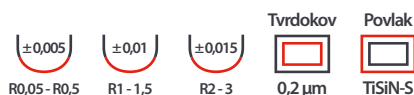

NOVINKA

Objednací číslo	D (mm)	R (mm)	L1 (mm)	L (mm)	d h5 (mm)	Standardní položka
4JJC-005-0005-S04	0,5	R 0,05	1	45	4	☑
4JJC-005-001-S04		R 0,1	1	45	4	☑
4JJC-006-0005-S04	0,6	R 0,05	1,2	45	4	☑
4JJC-006-001-S04		R 0,1	1,2	45	4	☑
4JJC-007-0005-S04	0,7	R 0,05	1,4	45	4	☑
4JJC-007-001-S04		R 0,1	1,4	45	4	☑
4JJC-008-0005-S04	0,8	R 0,05	1,6	45	4	☑
4JJC-008-001-S04		R 0,1	1,6	45	4	☑
4JJC-009-0005-S04	0,9	R 0,05	1,8	45	4	☑
4JJC-009-001-S04		R 0,1	1,8	45	4	☑
4JJC-010-0005-S04	1	R 0,05	2,5	45	4	☑
4JJC-010-001-S04		R 0,1	2,5	45	4	☑
4JJC-010-002-S04		R 0,2	2,5	45	4	☑
4JJC-010-003-S04		R 0,3	2,5	45	4	☑
4JJC-015-0005-S04	1,5	R 0,05	4	45	4	☑
4JJC-015-001-S04		R 0,1	4	45	4	☑
4JJC-015-002-S04		R 0,2	4	45	4	☑
4JJC-015-003-S04		R 0,3	4	45	4	☑
4JJC-015-005-S04	2	R 0,5	4	45	4	☑
4JJC-020-0005-S04		R 0,05	6	45	4	☑
4JJC-020-001-S04		R 0,1	6	45	4	☑
4JJC-020-002-S04		R 0,2	6	45	4	☑
4JJC-020-003-S04		R 0,3	6	45	4	☑
4JJC-020-005-S04	2,5	R 0,5	6	45	4	☑
4JJC-025-001-S04		R 0,1	6	50	4	☑
4JJC-025-002-S04		R 0,2	6	50	4	☑
4JJC-025-003-S04		R 0,3	6	50	4	☑
4JJC-025-005-S04	3	R 0,5	6	50	4	☑
4JJC-030-001-S03		R 0,1	8	60	3	☑
4JJC-030-002-S03		R 0,2	8	60	3	☑
4JJC-030-003-S03		R 0,3	8	60	3	☑
4JJC-030-005-S03		R 0,5	8	60	3	☑
4JJC-030-010-S03		R 1	8	60	3	☑
4JJC-030-001-S06		R 0,1	8	60	6	☑
4JJC-030-002-S06		R 0,2	8	60	6	☑
4JJC-030-003-S06	R 0,3	8	60	6	☑	
4JJC-030-005-S06	R 0,5	8	60	6	☑	
4JJC-030-010-S06	R 1	8	60	6	☑	

Objednací číslo	D (mm)	R (mm)	L1 (mm)	L (mm)	d h5 (mm)	Standardní položka
4JJC-035-001-S06	3,5	R 0,1	9	70	6	☑
4JJC-035-002-S06		R 0,2	9	70	6	☑
4JJC-035-003-S06		R 0,3	9	70	6	☑
4JJC-035-005-S06		R 0,5	9	70	6	☑
4JJC-035-010-S06		R 1	9	70	6	☑
4JJC-040-001-S04	4	R 0,1	9	60	4	☑
4JJC-040-001-S06		R 0,1	10	70	6	☑
4JJC-040-002-S04		R 0,2	9	60	4	☑
4JJC-040-002-S06		R 0,2	10	70	6	☑
4JJC-040-003-S04		R 0,3	9	60	4	☑
4JJC-040-003-S06		R 0,3	10	70	6	☑
4JJC-040-005-S04		R 0,5	9	60	4	☑
4JJC-040-005-S06		R 0,5	10	70	6	☑
4JJC-040-010-S04		R 1	9	60	4	☑
4JJC-040-010-S06		R 1	10	70	6	☑
4JJC-045-002-S06	4,5	R 0,2	11	75	6	☑
4JJC-045-003-S06		R 0,3	11	75	6	☑
4JJC-045-005-S06		R 0,5	11	75	6	☑
4JJC-045-010-S06	R 1	11	75	6	☑	
4JJC-050-001-S06	5	R 0,1	13	75	6	☑
4JJC-050-002-S06		R 0,2	13	75	6	☑
4JJC-050-003-S06		R 0,3	13	75	6	☑
4JJC-050-005-S06		R 0,5	13	75	6	☑
4JJC-050-010-S06		R 1	13	75	6	☑
4JJC-060-0005-055	6	R 0,05	11	55	6	☑
4JJC-060-0005-080		R 0,05	13	80	6	☑
4JJC-060-001-055		R 0,1	11	55	6	☑
4JJC-060-001-080		R 0,1	13	80	6	☑
4JJC-060-002-055		R 0,2	11	55	6	☑
4JJC-060-002-080		R 0,2	13	80	6	☑
4JJC-060-002-100		R 0,2	13	100	6	☑
4JJC-060-002-120		R 0,2	13	120	6	☑
4JJC-060-003-055		R 0,3	11	55	6	☑
4JJC-060-003-080		R 0,3	13	80	6	☑
4JJC-060-003-100		R 0,3	13	100	6	☑
4JJC-060-003-120		R 0,3	13	120	6	☑
4JJC-060-005-055		R 0,5	11	55	6	☑
4JJC-060-005-080		R 0,5	13	80	6	☑

NOVINKA

Objednací číslo	D (mm)	R (mm)	L1 (mm)	L (mm)	d h5 (mm)	Standardní položka	
4JJC-060-005-100	6	R 0,5	13	100	6	☑	
4JJC-060-005-120		R 0,5	13	120	6	☑	
4JJC-060-010-055		R 1	11	55	6	☑	
4JJC-060-010-080		R 1	13	80	6	☑	
4JJC-060-010-100		R 1	13	100	6	☑	
4JJC-060-010-120		R 1	13	120	6	☑	
4JJC-060-015-055		R 1,5	11	55	6	☑	
4JJC-060-015-080		R 1,5	13	80	6	☑	
4JJC-060-020-055		R 2	11	55	6	☑	
4JJC-060-020-080		R 2	13	80	6	☑	
4JJC-070-002-S08		7	R 0,2	16	80	8	☑
4JJC-070-003-S08			R 0,3	16	80	8	☑
4JJC-070-005-S08	R 0,5		16	80	8	☑	
4JJC-070-010-S08	R 1		16	80	8	☑	
4JJC-080-001-060	8	R 0,1	16	60	8	☑	
4JJC-080-001-090		R 0,1	19	90	8	☑	
4JJC-080-002-060		R 0,2	16	60	8	☑	
4JJC-080-002-090		R 0,2	19	90	8	☑	
4JJC-080-003-060		R 0,3	16	60	8	☑	
4JJC-080-003-090		R 0,3	19	90	8	☑	
4JJC-080-005-060		R 0,5	16	60	8	☑	
4JJC-080-005-090		R 0,5	19	90	8	☑	
4JJC-080-005-110		R 0,5	19	110	8	☑	
4JJC-080-005-150		R 0,5	19	150	8	☑	
4JJC-080-010-060		R 1	16	60	8	☑	
4JJC-080-010-090		R 1	19	90	8	☑	
4JJC-080-010-110		R 1	19	110	8	☑	
4JJC-080-010-150		R 1	19	150	8	☑	
4JJC-080-015-060		R 1,5	16	60	8	☑	
4JJC-080-015-090		R 1,5	19	90	8	☑	
4JJC-080-020-060		R 2	16	60	8	☑	
4JJC-080-020-090		R 2	19	90	8	☑	
4JJC-090-002-S10		9	R 0,2	20	90	10	☑
4JJC-090-003-S10			R 0,3	20	90	10	☑
4JJC-090-005-S10	R 0,5		20	90	10	☑	
4JJC-090-010-S10	R 1		20	90	10	☑	
4JJC-100-001-070	10	R 0,1	19	70	10	☑	
4JJC-100-001-100		R 0,1	22	100	10	☑	
4JJC-100-002-070		R 0,2	19	70	10	☑	
4JJC-100-002-100		R 0,2	22	100	10	☑	
4JJC-100-003-070		R 0,3	19	70	10	☑	
4JJC-100-003-100		R 0,3	22	100	10	☑	
4JJC-100-005-070		R 0,5	19	70	10	☑	
4JJC-100-005-100		R 0,5	22	100	10	☑	
4JJC-100-005-120		R 0,5	22	120	10	☑	
4JJC-100-005-150		R 0,5	22	150	10	☑	
4JJC-100-010-070		R 1	19	70	10	☑	
4JJC-100-010-100		R 1	22	100	10	☑	
4JJC-100-010-120		R 1	22	120	10	☑	
4JJC-100-010-150		R 1	22	150	10	☑	
4JJC-100-015-070		R 1,5	19	70	10	☑	
4JJC-100-015-100	R 1,5	22	100	10	☑		

Objednací číslo	D (mm)	R (mm)	L1 (mm)	L (mm)	d h5 (mm)	Standardní položka
4JJC-100-020-070	10	R 2	19	70	10	☑
4JJC-100-020-100		R 2	22	100	10	☑
4JJC-100-020-120		R 2	22	120	10	☑
4JJC-100-020-150		R 2	22	150	10	☑
4JJC-100-025-070		R 2,5	19	70	10	☑
4JJC-100-025-100		R 2,5	22	100	10	☑
4JJC-110-003-S12	11	R 0,3	24	100	12	☑
4JJC-110-005-S12		R 0,5	24	100	12	☑
4JJC-110-010-S12		R 1	24	100	12	☑
4JJC-120-001-075	12	R 0,1	22	75	12	☑
4JJC-120-001-110		R 0,1	26	110	12	☑
4JJC-120-002-075		R 0,2	22	75	12	☑
4JJC-120-002-110		R 0,2	26	110	12	☑
4JJC-120-003-075		R 0,3	22	75	12	☑
4JJC-120-003-110		R 0,3	26	110	12	☑
4JJC-120-005-075		R 0,5	22	75	12	☑
4JJC-120-005-110		R 0,5	26	110	12	☑
4JJC-120-005-130		R 0,5	26	130	12	☑
4JJC-120-005-160		R 0,5	26	160	12	☑
4JJC-120-010-075		R 1	22	75	12	☑
4JJC-120-010-110		R 1	26	110	12	☑
4JJC-120-010-130		R 1	26	130	12	☑
4JJC-120-010-160		R 1	26	160	12	☑
4JJC-120-015-075		R 1,5	22	75	12	☑
4JJC-120-015-110		R 1,5	26	110	12	☑
4JJC-120-020-075		R 2	22	75	12	☑
4JJC-120-020-110		R 2	26	110	12	☑
4JJC-120-020-130		R 2	26	130	12	☑
4JJC-120-020-160		R 2	26	160	12	☑
4JJC-120-025-075	R 2,5	22	75	12	☑	
4JJC-120-025-110	R 2,5	26	110	12	☑	
4JJC-120-030-075	R 3	22	75	12	☑	
4JJC-120-030-110	R 3	26	110	12	☑	
4JJC-140-005-110	14	R 0,5	30	110	14	☑
4JJC-140-010-110		R 1	30	110	14	☑
4JJC-140-020-110		R 2	30	110	14	☑
4JJC-160-005-110	16	R 0,5	32	110	16	☑
4JJC-160-005-160		R 0,5	32	160	16	☑
4JJC-160-010-110		R 1	32	110	16	☑
4JJC-160-010-160		R 1	32	160	16	☑

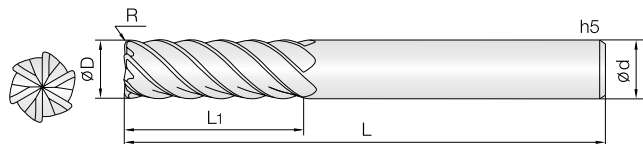

- Určeno pro kalené oceli (52–68 HRC)
- Vysoká odolnost proti opotřebení díky novému PVD povlaku s vysokým obsahem Si
- Velmi přesné tolerance řezných hran
- Minimalizace vyštipování díky zesílení řezné hrany a rohovému rádiu
- Vyšší posuvy díky 45° geometrii
- Vynikající výkon při vysokých řezných rychlostech díky 0,2 μm tvrdokovu



NOVINKA

Objednací číslo	D (mm)	R (mm)	L1 (mm)	L (mm)	d h5 (mm)	Standardní položka	
6JJCRL-030-001-060	3	R 0,1	7,5	60	6	☑	
6JJCRL-030-002-060		R 0,2	7,5	60	6	☑	
6JJCRL-030-003-060		R 0,3	7,5	60	6	☑	
6JJCRL-030-005-060		R 0,5	7,5	60	6	☑	
6JJCRL-030-010-060		R 1	7,5	60	6	☑	
6JJCRL-040-001-060	4	R 0,1	10	60	6	☑	
6JJCRL-040-002-060		R 0,2	10	60	6	☑	
6JJCRL-040-003-060		R 0,3	10	60	6	☑	
6JJCRL-040-005-060		R 0,5	10	60	6	☑	
6JJCRL-040-010-060		R 1	10	60	6	☑	
6JJCRL-050-002-060	5	R 0,2	13	60	6	☑	
6JJCRL-050-003-060		R 0,3	13	60	6	☑	
6JJCRL-050-005-060		R 0,5	13	60	6	☑	
6JJCRL-050-010-060		R 1	13	60	6	☑	
6JJCRL-060-001-060		6	R 0,1	15	60	6	☑
6JJCRL-060-002-060	R 0,2		15	60	6	☑	
6JJCRL-060-002-080	R 0,2		15	80	6	☑	
6JJCRL-060-003-060	R 0,3		15	60	6	☑	
6JJCRL-060-003-080	R 0,3		15	80	6	☑	
6JJCRL-060-005-060	R 0,5		15	60	6	☑	
6JJCRL-060-005-080	R 0,5		15	80	6	☑	
6JJCRL-060-010-060	R 1		15	60	6	☑	
6JJCRL-060-010-080	R 1		15	80	6	☑	
6JJCRL-080-002-070	8		R 0,2	20	70	8	☑
6JJCRL-080-003-070		R 0,3	20	70	8	☑	
6JJCRL-080-003-090		R 0,3	20	90	8	☑	
6JJCRL-080-005-070		R 0,5	20	70	8	☑	
6JJCRL-080-005-090		R 0,5	20	90	8	☑	
6JJCRL-080-010-070		R 1	20	70	8	☑	
6JJCRL-080-010-090		R 1	20	90	8	☑	
6JJCRL-080-015-070		R 1,5	20	70	8	☑	
6JJCRL-100-002-075		10	R 0,2	25	75	10	☑
6JJCRL-100-003-075			R 0,3	25	75	10	☑
6JJCRL-100-003-100	R 0,3		25	100	10	☑	
6JJCRL-100-005-075	R 0,5		25	75	10	☑	
6JJCRL-100-005-100	R 0,5		25	100	10	☑	
6JJCRL-100-010-075	R 1		25	75	10	☑	
6JJCRL-100-010-100	R 1		25	100	10	☑	

Objednací číslo	D (mm)	R (mm)	L1 (mm)	L (mm)	d h5 (mm)	Standardní položka	
6JJCRL-100-020-075	10	R 2	25	75	10	☑	
6JJCRL-120-002-080	12	R 0,2	30	80	12	☑	
6JJCRL-120-003-080		R 0,3	30	80	12	☑	
6JJCRL-120-003-110		R 0,3	30	110	12	☑	
6JJCRL-120-005-080		R 0,5	30	80	12	☑	
6JJCRL-120-005-110		R 0,5	30	110	12	☑	
6JJCRL-120-010-080		R 1	30	80	12	☑	
6JJCRL-120-010-110		R 1	30	110	12	☑	
6JJCRL-120-020-080		R 2	30	80	12	☑	
6JJCRL-160-005-110		16	R 0,5	50	110	16	☑
6JJCRL-160-010-110			R 1	50	110	16	☑
6JJCRL-160-020-110	R 2		50	110	16	☑	

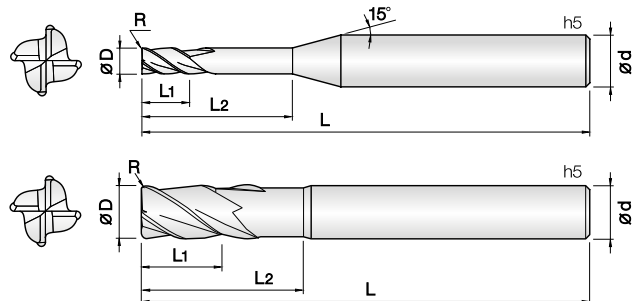

- Určeno pro kalené oceli (52–68 HRC)
- Vysoká odolnost proti opotřeby díky PVD povlaku na bázi Si
- Určeno pro vysoké posuvy při nižších řezných rychlostech
- Vhodné pro náročné a hrubovací obrábění
- Minimalizace vyštipování díky tvrdokovu s vysokou houževnatostí

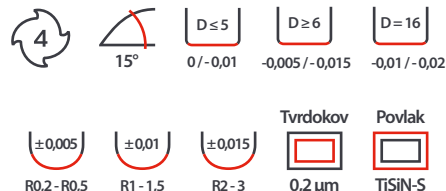

Objednací číslo	D (mm)	R (mm)	L2 (mm)	L1 (mm)	L (mm)	d h5 (mm)	Standardní položka
4JJRC-010-002-025	1	R 0,2	2,5	1	50	4	☑
4JJRC-015-005-040	1,5	R 0,5	4	1,5	50	4	☑
4JJRC-020-005-060	2	R 0,5	6	2	50	6	☑
4JJRC-030-005-080	3	R 0,5	8	3	50	6	☑
4JJRC-040-005-120	4	R 0,5	12	4	60	6	☑
4JJRC-040-005-160			16	4	60	6	☑
4JJRC-040-010-120		R 1	12	4	60	6	☑
4JJRC-040-010-160			16	4	60	6	☑
4JJRC-050-005-150	5	R 0,5	15	5	60	6	☑
4JJRC-050-010-150		R 1	15	5	60	6	☑
4JJRC-060-003-150	6	R 0,3	15	6	60	6	☑
4JJRC-060-005-150		R 0,5	15	6	60	6	☑
4JJRC-060-010-150		R 1	15	6	60	6	☑
4JJRC-060-015-150		R 1,5	15	6	60	6	☑
4JJRC-080-003-160	8	R 0,3	16	8	60	8	☑
4JJRC-080-005-160		R 0,5	16	8	60	8	☑
4JJRC-080-005-200			20	8	80	8	☑
4JJRC-080-005-300		R 1	30	8	110	8	☑
4JJRC-080-010-160			16	8	60	8	☑
4JJRC-080-010-200			20	8	80	8	☑
4JJRC-080-010-300			30	8	110	8	☑
4JJRC-080-020-160		R 2	16	8	60	8	☑
4JJRC-080-020-200	20		8	80	8	☑	
4JJRC-080-020-300	30	8	110	8	☑		
4JJRC-100-003-200	10	R 0,3	20	10	70	10	☑
4JJRC-100-005-200		R 0,5	20	10	70	10	☑
4JJRC-100-005-250			25	10	90	10	☑
4JJRC-100-005-300			30	10	120	10	☑
4JJRC-100-010-200		R 1	20	10	70	10	☑
4JJRC-100-010-250			25	10	90	10	☑
4JJRC-100-010-300			30	10	120	10	☑
4JJRC-100-020-200		R 2	20	10	70	10	☑
4JJRC-100-020-250			25	10	90	10	☑
4JJRC-100-020-300			30	10	120	10	☑
4JJRC-120-005-250	12		R 0,5	25	12	80	12
4JJRC-120-005-300		R 0,5	30	12	100	12	☑
4JJRC-120-005-350			35	12	130	12	☑
4JJRC-120-010-250		R 1	25	12	80	12	☑

Objednací číslo	D (mm)	R (mm)	L2 (mm)	L1 (mm)	L (mm)	d h5 (mm)	Standardní položka
4JJRC-120-010-300	12	R 1	30	12	100	12	☑
4JJRC-120-010-350			35	12	130	12	☑
4JJRC-120-020-250		R 2	25	12	80	12	☑
4JJRC-120-020-300			30	12	100	12	☑
4JJRC-120-020-350		R 3	35	12	130	12	☑
4JJRC-120-030-250			25	12	80	12	☑
4JJRC-160-010-300	16	R 1	30	16	110	16	☑
4JJRC-160-010-400			40	16	160	16	☑
4JJRC-160-020-300		R 2	30	16	110	16	☑
4JJRC-160-020-400			40	16	160	16	☑

4&6JJDRC

4 a 6-břité RYCHLOPOSUVOVÉ frézy 30°
pro kalené oceli do HRC 68

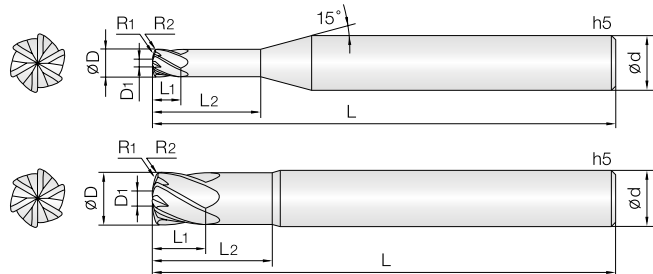

- ▶ Určeno pro kalené oceli (52–68 HRC)
- ▶ Vysoká odolnost proti opotřebení díky PVD povlaku na bázi Si
- ▶ Určeno pro vysoké posuvy při nižších řezných rychlostech
- ▶ Vhodné pro náročné a hrubovací obrábění
- ▶ Dvojitý rádius pro tvorbu menších třísek a tím i snížení řezného odporu



NOVINKA

Objednáací číslo	D (mm)	L2 (mm)	R1 (mm)	R2 (mm)	D1 (mm)	L1 (mm)	L (mm)	d h5 (mm)	Standardní položka
4JJDRC-010-010-030	1	3	1	0,1	0,28	1	50	4	<input checked="" type="checkbox"/>
4JJDRC-020-020-060	2	6	2	0,1	0,56	2	50	6	<input checked="" type="checkbox"/>
4JJDRC-030-030-090	3	9	3	0,2	0,68	3	60	6	<input checked="" type="checkbox"/>
4JJDRC-040-040-120	4	12	4	0,2	0,8	4	60	6	<input checked="" type="checkbox"/>
4JJDRC-050-050-150	5	15	5	0,3	1,08	5	60	6	<input checked="" type="checkbox"/>
6JJDRC-060-060-180	6	18	6	0,3	1,22	6	60	6	<input checked="" type="checkbox"/>
6JJDRC-080-080-240	8	24	8	0,5	1,76	8	75	8	<input checked="" type="checkbox"/>
6JJDRC-100-100-300	10	30	10	0,5	2,02	10	80	10	<input checked="" type="checkbox"/>
6JJDRC-120-120-360	12	36	12	0,5	2,28	12	100	12	<input checked="" type="checkbox"/>
6JJDRC-160-160-450	16	45	16	0,8	2,8	16	110	16	<input checked="" type="checkbox"/>

HS

- ▶ Tvrdivé frézy pro kalené oceli do max. tvrdosti HRC 62
- ▶ Vhodné i pro HSC obrábění

2HRB

2-břité KULOVÉ frézy pro žebrování pro kalené oceli do HRC 62

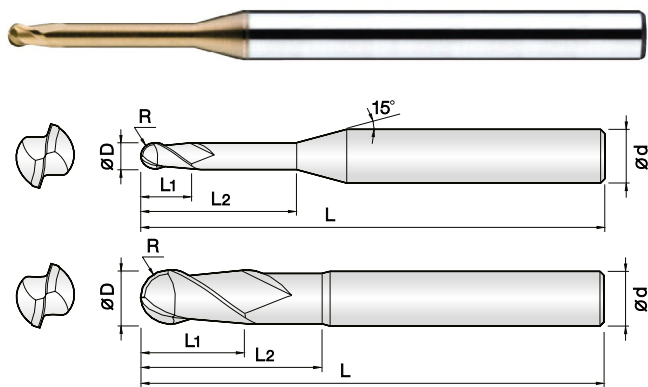

- Určeno pro kalené oceli (50–62 HRC)
- Vysoká odolnost proti opotřeбенí díky PVD povlaku na bázi Si
- Velmi přesné tolerance rezných hran
- Široký sortiment vyložení pro optimální výběr nástroje
- Vysoká kvalita obrobeného povrchu
- Vynikající výkon při vysokých rezných rychlostech díky 0,2 µm tvrdkovu



NOVINKA

Objednací číslo	D (mm)	R (mm)	L2 (mm)	L1 (mm)	L (mm)	d h5 (mm)	Standardní položka
2HRB-001-003-S04	0,1	R 0,05	0,3	0,15	40	4	☑
2HRB-001-005-S04			0,5	0,15	40	4	☑
2HRB-0015-003-S04	0,15	R 0,075	0,3	0,15	40	4	☑
2HRB-0015-005-S04			0,5	0,15	40	4	☑
2HRB-0015-010-S04			1	0,15	40	4	☑
2HRB-002-005-S04	0,2	R 0,1	0,5	0,2	40	4	☑
2HRB-002-010-S04			1	0,2	40	4	☑
2HRB-002-015-S04			1,5	0,2	40	4	☑
2HRB-002-020-S04			2	0,2	40	4	☑
2HRB-002-025-S04			2,5	0,2	40	4	☑
2HRB-002-030-S04			3	0,2	40	4	☑
2HRB-0025-005-S04	0,25	R 0,125	0,5	0,25	40	4	☑
2HRB-0025-010-S04			1	0,25	40	4	☑
2HRB-0025-015-S04			1,5	0,25	40	4	☑
2HRB-0025-020-S04			2	0,25	40	4	☑
2HRB-0025-025-S04			2,5	0,25	40	4	☑
2HRB-0025-030-S04			3	0,25	40	4	☑
2HRB-003-010-S04	0,3	R 0,15	1	0,3	40	4	☑
2HRB-003-015-S04			1,5	0,3	40	4	☑
2HRB-003-020-S04			2	0,3	40	4	☑
2HRB-003-025-S04			2,5	0,3	40	4	☑
2HRB-003-030-S04			3	0,3	40	4	☑
2HRB-003-035-S04			3,5	0,3	40	4	☑
2HRB-003-040-S04			4	0,3	40	4	☑
2HRB-003-050-S04			5	0,3	40	4	☑
2HRB-004-010-S04	0,4	R 0,2	1	0,4	40	4	☑
2HRB-004-015-S04			1,5	0,4	40	4	☑
2HRB-004-020-S04			2	0,4	40	4	☑
2HRB-004-025-S04			2,5	0,4	40	4	☑
2HRB-004-030-S04			3	0,4	40	4	☑
2HRB-004-035-S04			3,5	0,4	40	4	☑
2HRB-004-040-S04			4	0,4	40	4	☑
2HRB-004-045-S04			4,5	0,4	40	4	☑
2HRB-004-050-S04			5	0,4	40	4	☑
2HRB-004-060-S04			6	0,4	40	4	☑
2HRB-004-080-S04	8	0,4	40	4	☑		
2HRB-004-100-S04	10	0,4	40	4	☑		
2HRB-005-010-S04	0,5	R 0,25	1	0,5	45	4	☑

Objednací číslo	D (mm)	R (mm)	L2 (mm)	L1 (mm)	L (mm)	d h5 (mm)	Standardní položka
2HRB-005-015-S04	0,5	R 0,25	1,5	0,5	45	4	☑
2HRB-005-020-S04			2	0,5	45	4	☑
2HRB-005-025-S04			2,5	0,5	45	4	☑
2HRB-005-030-S04			3	0,5	45	4	☑
2HRB-005-035-S04			3,5	0,5	45	4	☑
2HRB-005-040-S04			4	0,5	45	4	☑
2HRB-005-045-S04			4,5	0,5	45	4	☑
2HRB-005-050-S04			5	0,5	45	4	☑
2HRB-005-060-S04			6	0,5	45	4	☑
2HRB-005-080-S04			8	0,5	45	4	☑
2HRB-005-100-S04			10	0,5	45	4	☑
2HRB-005-120-S04			12	0,5	45	4	☑
2HRB-005-140-S04			14	0,5	45	4	☑
2HRB-006-010-S04			0,6	R 0,3	1	0,6	45
2HRB-006-020-S04	2	0,6			45	4	☑
2HRB-006-030-S04	3	0,6			45	4	☑
2HRB-006-040-S04	4	0,6			45	4	☑
2HRB-006-050-S04	5	0,6			45	4	☑
2HRB-006-060-S04	6	0,6			45	4	☑
2HRB-006-080-S04	8	0,6			45	4	☑
2HRB-006-100-S04	10	0,6			45	4	☑
2HRB-006-120-S04	12	0,6	45	4	☑		
2HRB-006-140-S04	14	0,6	45	4	☑		
2HRB-006-160-S04	16	0,6	45	4	☑		
2HRB-007-020-S04	0,7	R 0,35	2	0,7	45	4	☑
2HRB-007-040-S04			4	0,7	45	4	☑
2HRB-007-060-S04			6	0,7	45	4	☑
2HRB-007-080-S04			8	0,7	45	4	☑
2HRB-007-100-S04			10	0,7	45	4	☑
2HRB-007-120-S04			12	0,7	45	4	☑
2HRB-008-020-S04	0,8	R 0,4	2	0,8	45	4	☑
2HRB-008-030-S04			3	0,8	45	4	☑
2HRB-008-040-S04			4	0,8	45	4	☑
2HRB-008-050-S04			5	0,8	45	4	☑
2HRB-008-060-S04			6	0,8	45	4	☑
2HRB-008-080-S04			8	0,8	45	4	☑
2HRB-008-100-S04			10	0,8	45	4	☑
2HRB-008-120-S04	12	0,8	45	4	☑		

Objednací číslo	D (mm)	R (mm)	L2 (mm)	L1 (mm)	L (mm)	d h5 (mm)	Standardní položka		
2HRB-008-140-S04	0,8	R 0,4	14	0,8	45	4	<input checked="" type="checkbox"/>		
2HRB-008-160-S04			16	0,8	45	4	<input checked="" type="checkbox"/>		
2HRB-009-040-S04	0,9	R 0,45	4	0,9	45	4	<input checked="" type="checkbox"/>		
2HRB-010-020-S04	1	R 0,5	2	1	45	4	<input checked="" type="checkbox"/>		
2HRB-010-020-S06			2	1	50	6	<input checked="" type="checkbox"/>		
2HRB-010-030-S04			3	1	45	4	<input checked="" type="checkbox"/>		
2HRB-010-030-S06			3	1	50	6	<input checked="" type="checkbox"/>		
2HRB-010-040-S04			4	1	45	4	<input checked="" type="checkbox"/>		
2HRB-010-040-S06			4	1	50	6	<input checked="" type="checkbox"/>		
2HRB-010-050-S04			5	1	45	4	<input checked="" type="checkbox"/>		
2HRB-010-050-S06			5	1	50	6	<input checked="" type="checkbox"/>		
2HRB-010-060-S04			6	1	45	4	<input checked="" type="checkbox"/>		
2HRB-010-060-S06			6	1	50	6	<input checked="" type="checkbox"/>		
2HRB-010-080-S04			8	1	45	4	<input checked="" type="checkbox"/>		
2HRB-010-080-S06			8	1	50	6	<input checked="" type="checkbox"/>		
2HRB-010-100-S04			10	1	50	4	<input checked="" type="checkbox"/>		
2HRB-010-100-S06			10	1	50	6	<input checked="" type="checkbox"/>		
2HRB-010-120-S04			12	1	50	4	<input checked="" type="checkbox"/>		
2HRB-010-120-S06			12	1	50	6	<input checked="" type="checkbox"/>		
2HRB-010-140-S04			14	1	50	4	<input checked="" type="checkbox"/>		
2HRB-010-140-S06			14	1	50	6	<input checked="" type="checkbox"/>		
2HRB-010-160-S04			16	1	50	4	<input checked="" type="checkbox"/>		
2HRB-010-160-S06			16	1	60	6	<input checked="" type="checkbox"/>		
2HRB-010-180-S04	18	1	50	4	<input checked="" type="checkbox"/>				
2HRB-010-180-S06	18	1	60	6	<input checked="" type="checkbox"/>				
2HRB-010-200-S04	20	1	50	4	<input checked="" type="checkbox"/>				
2HRB-010-200-S06	20	1	60	6	<input checked="" type="checkbox"/>				
2HRB-010-220-S04	22	1	60	4	<input checked="" type="checkbox"/>				
2HRB-010-220-S06	22	1	65	6	<input checked="" type="checkbox"/>				
2HRB-010-250-S04	25	1	60	4	<input checked="" type="checkbox"/>				
2HRB-010-300-S04	30	1	70	4	<input checked="" type="checkbox"/>				
2HRB-012-040-S04	1,2	R 0,6	4	1,2	45	4	<input checked="" type="checkbox"/>		
2HRB-012-040-S06			4	1,2	50	6	<input checked="" type="checkbox"/>		
2HRB-012-060-S04			6	1,2	45	4	<input checked="" type="checkbox"/>		
2HRB-012-060-S06			6	1,2	50	6	<input checked="" type="checkbox"/>		
2HRB-012-080-S04			8	1,2	45	4	<input checked="" type="checkbox"/>		
2HRB-012-080-S06			8	1,2	50	6	<input checked="" type="checkbox"/>		
2HRB-012-100-S04			10	1,2	50	4	<input checked="" type="checkbox"/>		
2HRB-012-100-S06			10	1,2	50	6	<input checked="" type="checkbox"/>		
2HRB-012-120-S04			12	1,2	50	4	<input checked="" type="checkbox"/>		
2HRB-012-120-S06			12	1,2	50	6	<input checked="" type="checkbox"/>		
2HRB-012-160-S04			16	1,2	50	4	<input checked="" type="checkbox"/>		
2HRB-012-160-S06			16	1,2	60	6	<input checked="" type="checkbox"/>		
2HRB-012-200-S04			20	1,2	50	4	<input checked="" type="checkbox"/>		
2HRB-012-200-S06			20	1,2	60	6	<input checked="" type="checkbox"/>		
2HRB-012-240-S04			24	1,2	60	4	<input checked="" type="checkbox"/>		
2HRB-012-240-S06			24	1,2	65	6	<input checked="" type="checkbox"/>		
2HRB-014-060-S04			1,4	R 0,7	6	1,4	45	4	<input checked="" type="checkbox"/>
2HRB-014-080-S04					8	1,4	45	4	<input checked="" type="checkbox"/>
2HRB-014-120-S04					12	1,4	50	4	<input checked="" type="checkbox"/>
2HRB-014-160-S04					16	1,4	50	4	<input checked="" type="checkbox"/>
2HRB-015-030-S04	1,5	R 0,75	3	1,5	45	4	<input checked="" type="checkbox"/>		

Objednací číslo	D (mm)	R (mm)	L2 (mm)	L1 (mm)	L (mm)	d h5 (mm)	Standardní položka
2HRB-015-030-S06	1,5	R 0,75	3	1,5	50	6	<input checked="" type="checkbox"/>
2HRB-015-040-S04			4	1,5	45	4	<input checked="" type="checkbox"/>
2HRB-015-040-S06			4	1,5	50	6	<input checked="" type="checkbox"/>
2HRB-015-060-S04			6	1,5	45	4	<input checked="" type="checkbox"/>
2HRB-015-060-S06			6	1,5	50	6	<input checked="" type="checkbox"/>
2HRB-015-080-S04			8	1,5	45	4	<input checked="" type="checkbox"/>
2HRB-015-080-S06			8	1,5	50	6	<input checked="" type="checkbox"/>
2HRB-015-100-S04			10	1,5	50	4	<input checked="" type="checkbox"/>
2HRB-015-100-S06			10	1,5	50	6	<input checked="" type="checkbox"/>
2HRB-015-120-S04			12	1,5	50	4	<input checked="" type="checkbox"/>
2HRB-015-120-S06			12	1,5	50	6	<input checked="" type="checkbox"/>
2HRB-015-140-S04			14	1,5	50	4	<input checked="" type="checkbox"/>
2HRB-015-140-S06			14	1,5	50	6	<input checked="" type="checkbox"/>
2HRB-015-160-S04			16	1,5	50	4	<input checked="" type="checkbox"/>
2HRB-015-160-S06			16	1,5	60	6	<input checked="" type="checkbox"/>
2HRB-015-180-S04			18	1,5	50	4	<input checked="" type="checkbox"/>
2HRB-015-180-S06			18	1,5	60	6	<input checked="" type="checkbox"/>
2HRB-015-200-S04			20	1,5	50	4	<input checked="" type="checkbox"/>
2HRB-015-200-S06			20	1,5	60	6	<input checked="" type="checkbox"/>
2HRB-015-220-S04			22	1,5	60	4	<input checked="" type="checkbox"/>
2HRB-015-220-S06	22	1,5	65	6	<input checked="" type="checkbox"/>		
2HRB-015-250-S04	25	1,5	60	4	<input checked="" type="checkbox"/>		
2HRB-015-250-S06	25	1,5	65	6	<input checked="" type="checkbox"/>		
2HRB-015-300-S04	30	1,5	70	4	<input checked="" type="checkbox"/>		
2HRB-015-300-S06	30	1,5	70	6	<input checked="" type="checkbox"/>		
2HRB-015-350-S04	35	1,5	70	4	<input checked="" type="checkbox"/>		
2HRB-015-400-S04	40	1,5	80	4	<input checked="" type="checkbox"/>		
2HRB-016-060-S04	1,6	R 0,8	6	1,6	45	4	<input checked="" type="checkbox"/>
2HRB-016-080-S04			8	1,6	45	4	<input checked="" type="checkbox"/>
2HRB-016-120-S04			12	1,6	50	4	<input checked="" type="checkbox"/>
2HRB-016-160-S04			16	1,6	50	4	<input checked="" type="checkbox"/>
2HRB-016-200-S04	20	1,6	50	4	<input checked="" type="checkbox"/>		
2HRB-018-060-S04	1,8	R 0,9	6	1,8	45	4	<input checked="" type="checkbox"/>
2HRB-018-080-S04			8	1,8	45	4	<input checked="" type="checkbox"/>
2HRB-018-120-S04			12	1,8	50	4	<input checked="" type="checkbox"/>
2HRB-018-160-S04			16	1,8	50	4	<input checked="" type="checkbox"/>
2HRB-018-200-S04	20	1,8	50	4	<input checked="" type="checkbox"/>		
2HRB-020-040-S04	2	R 1	4	2	45	4	<input checked="" type="checkbox"/>
2HRB-020-040-S06			4	2	50	6	<input checked="" type="checkbox"/>
2HRB-020-060-S04			6	2	45	4	<input checked="" type="checkbox"/>
2HRB-020-060-S06			6	2	50	6	<input checked="" type="checkbox"/>
2HRB-020-080-S04			8	2	45	4	<input checked="" type="checkbox"/>
2HRB-020-080-S06			8	2	50	6	<input checked="" type="checkbox"/>
2HRB-020-100-S04			10	2	50	4	<input checked="" type="checkbox"/>
2HRB-020-100-S06			10	2	50	6	<input checked="" type="checkbox"/>
2HRB-020-120-S04			12	2	50	4	<input checked="" type="checkbox"/>
2HRB-020-120-S06			12	2	50	6	<input checked="" type="checkbox"/>
2HRB-020-140-S04			14	2	50	4	<input checked="" type="checkbox"/>
2HRB-020-140-S06			14	2	50	6	<input checked="" type="checkbox"/>
2HRB-020-160-S04			16	2	50	4	<input checked="" type="checkbox"/>
2HRB-020-160-S06			16	2	60	6	<input checked="" type="checkbox"/>
2HRB-020-180-S04	18	2	50	4	<input checked="" type="checkbox"/>		

Objednací číslo	D (mm)	R (mm)	L2 (mm)	L1 (mm)	L (mm)	d h5 (mm)	Standardní položka		
2HRB-020-180-S06	2	R 1	18	2	60	6	<input checked="" type="checkbox"/>		
2HRB-020-200-S04			20	2	50	4	<input checked="" type="checkbox"/>		
2HRB-020-200-S06			20	2	60	6	<input checked="" type="checkbox"/>		
2HRB-020-220-S04			22	2	60	4	<input checked="" type="checkbox"/>		
2HRB-020-220-S06			22	2	65	6	<input checked="" type="checkbox"/>		
2HRB-020-250-S04			25	2	60	4	<input checked="" type="checkbox"/>		
2HRB-020-250-S06			25	2	65	6	<input checked="" type="checkbox"/>		
2HRB-020-300-S04			30	2	70	4	<input checked="" type="checkbox"/>		
2HRB-020-300-S06			30	2	70	6	<input checked="" type="checkbox"/>		
2HRB-020-350-S04			35	2	70	4	<input checked="" type="checkbox"/>		
2HRB-020-350-S06			35	2	75	6	<input checked="" type="checkbox"/>		
2HRB-020-400-S04			40	2	80	4	<input checked="" type="checkbox"/>		
2HRB-020-400-S06			40	2	80	6	<input checked="" type="checkbox"/>		
2HRB-020-450-S04			45	2	80	4	<input checked="" type="checkbox"/>		
2HRB-020-500-S04			50	2	90	4	<input checked="" type="checkbox"/>		
2HRB-025-080-S04			2,5	R 1,25	8	2,5	45	4	<input checked="" type="checkbox"/>
2HRB-025-080-S06					8	2,5	50	6	<input checked="" type="checkbox"/>
2HRB-025-100-S04					10	2,5	50	4	<input checked="" type="checkbox"/>
2HRB-025-100-S06	10	2,5			50	6	<input checked="" type="checkbox"/>		
2HRB-025-120-S04	12	2,5			50	4	<input checked="" type="checkbox"/>		
2HRB-025-120-S06	12	2,5			50	6	<input checked="" type="checkbox"/>		
2HRB-025-160-S04	16	2,5			50	4	<input checked="" type="checkbox"/>		
2HRB-025-160-S06	16	2,5			60	6	<input checked="" type="checkbox"/>		
2HRB-025-200-S04	20	2,5			60	4	<input checked="" type="checkbox"/>		
2HRB-025-250-S04	25	2,5			60	4	<input checked="" type="checkbox"/>		
2HRB-025-300-S04	30	2,5			70	4	<input checked="" type="checkbox"/>		
2HRB-025-350-S04	35	2,5			70	4	<input checked="" type="checkbox"/>		
2HRB-025-400-S04	40	2,5			80	4	<input checked="" type="checkbox"/>		
2HRB-030-060-S06	3	R 1,5			6	3	50	6	<input checked="" type="checkbox"/>
2HRB-030-080-S06					8	3	50	6	<input checked="" type="checkbox"/>
2HRB-030-100-S06					10	3	50	6	<input checked="" type="checkbox"/>
2HRB-030-120-S06					12	3	50	6	<input checked="" type="checkbox"/>
2HRB-030-160-S06					16	3	60	6	<input checked="" type="checkbox"/>
2HRB-030-200-S06			20	3	60	6	<input checked="" type="checkbox"/>		
2HRB-030-250-S06			25	3	65	6	<input checked="" type="checkbox"/>		
2HRB-030-300-S06			30	3	70	6	<input checked="" type="checkbox"/>		
2HRB-030-350-S06			35	3	75	6	<input checked="" type="checkbox"/>		
2HRB-030-400-S06			40	3	80	6	<input checked="" type="checkbox"/>		
2HRB-030-450-S06			45	3	90	6	<input checked="" type="checkbox"/>		
2HRB-030-500-S06			50	3	100	6	<input checked="" type="checkbox"/>		
2HRB-030-600-S06			60	3	100	6	<input checked="" type="checkbox"/>		
2HRB-030-650-S06			65	3	110	6	<input checked="" type="checkbox"/>		
2HRB-030-700-S06			70	3	110	6	<input checked="" type="checkbox"/>		
2HRB-040-080-S06			4	R 2	8	4	50	6	<input checked="" type="checkbox"/>
2HRB-040-100-S06					10	4	50	6	<input checked="" type="checkbox"/>
2HRB-040-120-S06					12	4	50	6	<input checked="" type="checkbox"/>
2HRB-040-160-S06	16	4			60	6	<input checked="" type="checkbox"/>		
2HRB-040-200-S06	20	4			60	6	<input checked="" type="checkbox"/>		
2HRB-040-250-S06	25	4			65	6	<input checked="" type="checkbox"/>		
2HRB-040-300-S06	30	4			70	6	<input checked="" type="checkbox"/>		
2HRB-040-350-S06	35	4			75	6	<input checked="" type="checkbox"/>		
2HRB-040-400-S06	40	4	80	6	<input checked="" type="checkbox"/>				

Objednací číslo	D (mm)	R (mm)	L2 (mm)	L1 (mm)	L (mm)	d h5 (mm)	Standardní položka		
2HRB-040-450-S06	4	R 2	45	4	90	6	<input checked="" type="checkbox"/>		
2HRB-040-500-S06			50	4	100	6	<input checked="" type="checkbox"/>		
2HRB-040-550-S06			55	4	100	6	<input checked="" type="checkbox"/>		
2HRB-040-600-S06			60	4	100	6	<input checked="" type="checkbox"/>		
2HRB-040-650-S06			65	4	110	6	<input checked="" type="checkbox"/>		
2HRB-040-700-S06			70	4	110	6	<input checked="" type="checkbox"/>		
2HRB-050-160-S06			5	R 2,5	16	6	60	6	<input checked="" type="checkbox"/>
2HRB-050-200-S06					20	6	60	6	<input checked="" type="checkbox"/>
2HRB-050-250-S06	25	6			70	6	<input checked="" type="checkbox"/>		
2HRB-050-300-S06	30	6			75	6	<input checked="" type="checkbox"/>		
2HRB-050-400-S06	40	6			80	6	<input checked="" type="checkbox"/>		
2HRB-050-450-S06	45	6			90	6	<input checked="" type="checkbox"/>		
2HRB-050-500-S06	50	6			100	6	<input checked="" type="checkbox"/>		
2HRB-050-600-S06	60	6			100	6	<input checked="" type="checkbox"/>		
2HRB-050-650-S06	65	6			110	6	<input checked="" type="checkbox"/>		
2HRB-050-700-S06	70	6			110	6	<input checked="" type="checkbox"/>		
2HRB-060-150-S06	6	R 3			15	10	55	6	<input checked="" type="checkbox"/>
2HRB-060-300-S06					30	10	110	6	<input checked="" type="checkbox"/>
2HRB-080-250-060	8	R 4	25	12	60	8	<input checked="" type="checkbox"/>		
2HRB-080-300-100			30	12	100	8	<input checked="" type="checkbox"/>		
2HRB-100-300-070	10	R 5	30	16	70	10	<input checked="" type="checkbox"/>		
2HRB-100-350-100			35	16	100	10	<input checked="" type="checkbox"/>		
2HRB-120-300-075	12	R 6	30	18	75	12	<input checked="" type="checkbox"/>		
2HRB-120-400-110			40	18	110	12	<input checked="" type="checkbox"/>		

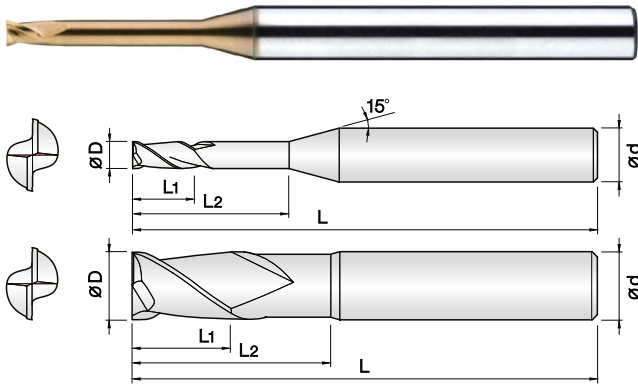

- ▶ **Určeno pro kalené oceli (50–60 HRC)**
- ▶ Vysoká odolnost proti opotřeбенí díky PVD povlaku na bázi Si
- ▶ Velmi přesné tolerance řezných hran
- ▶ Široký sortiment vyložení pro optimální výběr nástroje
- ▶ Minimalizace vyštipování díky zesílení řezné hrany
- ▶ Vynikající výkon při vysokých řezných rychlostech díky 0,2 μm tvrdokovu



NOVINKA

Objednací číslo	D (mm)	L2 (mm)	L1 (mm)	L (mm)	d h5 (mm)	Standardní položka
2HRE-001-003-S04	0,1	0,3	0,15	40	4	☑
2HRE-001-005-S04		0,5	0,15	40	4	☑
2HRE-0015-003-S04	0,15	0,3	0,15	40	4	☑
2HRE-0015-005-S04		0,5	0,15	40	4	☑
2HRE-0015-0075-S04		0,75	0,15	40	4	☑
2HRE-0015-010-S04		1	0,15	40	4	☑
2HRE-002-005-S04	0,2	0,5	0,2	40	4	☑
2HRE-002-010-S04		1	0,2	40	4	☑
2HRE-002-015-S04		1,5	0,2	40	4	☑
2HRE-002-020-S04		2	0,2	40	4	☑
2HRE-002-025-S04		2,5	0,2	40	4	☑
2HRE-002-030-S04	3	0,2	40	4	☑	
2HRE-0025-005-S04	0,25	0,5	0,25	40	4	☑
2HRE-0025-010-S04		1	0,25	40	4	☑
2HRE-0025-015-S04		1,5	0,25	40	4	☑
2HRE-0025-020-S04		2	0,25	40	4	☑
2HRE-0025-030-S04		3	0,25	40	4	☑
2HRE-003-010-S04	0,3	1	0,3	40	4	☑
2HRE-003-015-S04		1,5	0,3	40	4	☑
2HRE-003-020-S04		2	0,3	40	4	☑
2HRE-003-025-S04		2,5	0,3	40	4	☑
2HRE-003-030-S04		3	0,3	40	4	☑
2HRE-003-035-S04		3,5	0,3	40	4	☑
2HRE-003-040-S04		4	0,3	40	4	☑
2HRE-003-050-S04	5	0,3	40	4	☑	
2HRE-004-010-S04	0,4	1	0,4	40	4	☑
2HRE-004-015-S04		1,5	0,4	40	4	☑
2HRE-004-020-S04		2	0,4	40	4	☑
2HRE-004-025-S04		2,5	0,4	40	4	☑
2HRE-004-030-S04		3	0,4	40	4	☑
2HRE-004-035-S04		3,5	0,4	40	4	☑
2HRE-004-040-S04		4	0,4	40	4	☑
2HRE-004-050-S04		5	0,4	40	4	☑
2HRE-004-060-S04		6	0,4	40	4	☑
2HRE-004-080-S04		8	0,4	40	4	☑
2HRE-004-100-S04	10	0,4	40	4	☑	
2HRE-005-010-S04	0,5	1	0,5	40	4	☑
2HRE-005-020-S04		2	0,5	40	4	☑

Objednací číslo	D (mm)	L2 (mm)	L1 (mm)	L (mm)	d h5 (mm)	Standardní položka
2HRE-005-030-S04	0,5	3	0,5	40	4	☑
2HRE-005-040-S04		4	0,5	40	4	☑
2HRE-005-050-S04		5	0,5	40	4	☑
2HRE-005-060-S04		6	0,5	40	4	☑
2HRE-005-080-S04		8	0,5	40	4	☑
2HRE-005-100-S04		10	0,5	40	4	☑
2HRE-005-120-S04		12	0,5	45	4	☑
2HRE-005-140-S04	14	0,5	45	4	☑	
2HRE-006-010-S04	0,6	1	0,6	40	4	☑
2HRE-006-020-S04		2	0,6	40	4	☑
2HRE-006-030-S04		3	0,6	40	4	☑
2HRE-006-040-S04		4	0,6	40	4	☑
2HRE-006-050-S04		5	0,6	40	4	☑
2HRE-006-060-S04		6	0,6	40	4	☑
2HRE-006-080-S04		8	0,6	40	4	☑
2HRE-006-100-S04		10	0,6	40	4	☑
2HRE-006-120-S04		12	0,6	45	4	☑
2HRE-006-140-S04		14	0,6	45	4	☑
2HRE-006-160-S04	16	0,6	45	4	☑	
2HRE-007-020-S04	0,7	2	0,7	40	4	☑
2HRE-007-040-S04		4	0,7	40	4	☑
2HRE-007-060-S04		6	0,7	40	4	☑
2HRE-007-080-S04		8	0,7	40	4	☑
2HRE-007-100-S04		10	0,7	40	4	☑
2HRE-007-120-S04		12	0,7	45	4	☑
2HRE-008-020-S04	0,8	2	0,8	40	4	☑
2HRE-008-030-S04		3	0,8	40	4	☑
2HRE-008-040-S04		4	0,8	40	4	☑
2HRE-008-050-S04		5	0,8	40	4	☑
2HRE-008-060-S04		6	0,8	40	4	☑
2HRE-008-080-S04		8	0,8	40	4	☑
2HRE-008-100-S04		10	0,8	40	4	☑
2HRE-008-120-S04		12	0,8	45	4	☑
2HRE-008-140-S04	14	0,8	45	4	☑	
2HRE-009-060-S04	0,9	6	0,9	40	4	☑
2HRE-009-080-S04		8	0,9	40	4	☑
2HRE-009-100-S04		10	0,9	40	4	☑
2HRE-010-020-S04	1	2	1	45	4	☑

Objednací číslo	D (mm)	L2 (mm)	L1 (mm)	L (mm)	d h5 (mm)	Standardní položka
2HRE-010-030-S04	1	3	1	45	4	☑
2HRE-010-040-S04		4	1	45	4	☑
2HRE-010-050-S04		5	1	45	4	☑
2HRE-010-060-S04		6	1	45	4	☑
2HRE-010-080-S04		8	1	45	4	☑
2HRE-010-100-S04		10	1	45	4	☑
2HRE-010-120-S04		12	1	45	4	☑
2HRE-010-140-S04		14	1	45	4	☑
2HRE-010-160-S04		16	1	50	4	☑
2HRE-010-180-S04		18	1	50	4	☑
2HRE-010-200-S04		20	1	50	4	☑
2HRE-010-250-S04		25	1	60	4	☑
2HRE-010-300-S04		30	1	70	4	☑
2HRE-012-040-S04		1,2	4	1,2	45	4
2HRE-012-060-S04	6		1,2	45	4	☑
2HRE-012-080-S04	8		1,2	45	4	☑
2HRE-012-100-S04	10		1,2	45	4	☑
2HRE-012-120-S04	12		1,2	45	4	☑
2HRE-012-160-S04	16		1,2	50	4	☑
2HRE-012-200-S04	20		1,2	50	4	☑
2HRE-012-250-S04	25		1,2	60	4	☑
2HRE-012-300-S04	30	1,2	70	4	☑	
2HRE-014-060-S04	1,4	6	1,4	45	4	☑
2HRE-014-080-S04		8	1,4	45	4	☑
2HRE-014-100-S04		10	1,4	45	4	☑
2HRE-014-140-S04		14	1,4	45	4	☑
2HRE-014-160-S04		16	1,4	50	4	☑
2HRE-014-200-S04		20	1,4	50	4	☑
2HRE-015-040-S04	1,5	4	1,5	45	4	☑
2HRE-015-060-S04		6	1,5	45	4	☑
2HRE-015-080-S04		8	1,5	45	4	☑
2HRE-015-100-S04		10	1,5	45	4	☑
2HRE-015-120-S04		12	1,5	45	4	☑
2HRE-015-140-S04		14	1,5	50	4	☑
2HRE-015-160-S04		16	1,5	50	4	☑
2HRE-015-180-S04		18	1,5	50	4	☑
2HRE-015-200-S04		20	1,5	50	4	☑
2HRE-015-250-S04		25	1,5	60	4	☑
2HRE-015-300-S04	30	1,5	70	4	☑	
2HRE-016-100-S04	1,6	10	1,6	45	4	☑
2HRE-016-140-S04		14	1,6	45	4	☑
2HRE-016-180-S04		18	1,6	50	4	☑
2HRE-018-100-S04	1,8	10	1,8	45	4	☑
2HRE-018-140-S04		14	1,8	45	4	☑
2HRE-018-180-S04		18	1,8	50	4	☑
2HRE-020-040-S04	2	4	2	45	4	☑
2HRE-020-060-S04		6	2	45	4	☑
2HRE-020-080-S04		8	2	45	4	☑
2HRE-020-100-S04		10	2	45	4	☑
2HRE-020-120-S04		12	2	45	4	☑
2HRE-020-140-S04		14	2	45	4	☑
2HRE-020-160-S04		16	2	50	4	☑

Objednací číslo	D (mm)	L2 (mm)	L1 (mm)	L (mm)	d h5 (mm)	Standardní položka
2HRE-020-180-S04	2	18	2	50	4	☑
2HRE-020-200-S04		20	2	50	4	☑
2HRE-020-220-S04		22	2	60	4	☑
2HRE-020-250-S04		25	2	60	4	☑
2HRE-020-300-S04		30	2	60	4	☑
2HRE-020-350-S04		35	2	70	4	☑
2HRE-020-400-S04		40	2	80	4	☑
2HRE-020-450-S04		45	2	80	4	☑
2HRE-020-500-S04		50	2	90	4	☑
2HRE-025-080-S04		2,5	8	2,5	45	4
2HRE-025-100-S04	10		2,5	45	4	☑
2HRE-025-120-S04	12		2,5	45	4	☑
2HRE-025-160-S04	16		2,5	50	4	☑
2HRE-025-200-S04	20		2,5	50	4	☑
2HRE-025-250-S04	25		2,5	60	4	☑
2HRE-025-300-S04	30		2,5	70	4	☑
2HRE-025-350-S04	35		2,5	70	4	☑
2HRE-025-400-S04	40		2,5	80	4	☑
2HRE-025-500-S04	50		2,5	90	4	☑
2HRE-030-060-S06	3	6	3	45	6	☑
2HRE-030-080-S06		8	3	45	6	☑
2HRE-030-100-S06		10	3	45	6	☑
2HRE-030-120-S06		12	3	50	6	☑
2HRE-030-160-S06		16	3	55	6	☑
2HRE-030-200-S06		20	3	60	6	☑
2HRE-030-250-S06		25	3	65	6	☑
2HRE-030-300-S06		30	3	70	6	☑
2HRE-030-350-S06		35	3	75	6	☑
2HRE-030-400-S06		40	3	80	6	☑
2HRE-030-450-S06	45	3	90	6	☑	
2HRE-030-500-S06	50	3	100	6	☑	
2HRE-030-600-S06	60	3	100	6	☑	
2HRE-040-080-S06	4	8	4	50	6	☑
2HRE-040-100-S06		10	4	50	6	☑
2HRE-040-120-S06		12	4	50	6	☑
2HRE-040-160-S06		16	4	55	6	☑
2HRE-040-200-S06		20	4	60	6	☑
2HRE-040-250-S06		25	4	65	6	☑
2HRE-040-300-S06		30	4	70	6	☑
2HRE-040-350-S06		35	4	75	6	☑
2HRE-040-400-S06		40	4	80	6	☑
2HRE-040-450-S06		45	4	90	6	☑
2HRE-040-500-S06	50	4	100	6	☑	
2HRE-040-550-S06	55	4	100	6	☑	
2HRE-040-600-S06	60	4	100	6	☑	
2HRE-050-160-S06	5	16	6	55	6	☑
2HRE-050-200-S06		20	6	60	6	☑
2HRE-050-250-S06		25	6	65	6	☑
2HRE-050-300-S06		30	6	70	6	☑
2HRE-050-350-S06		35	6	75	6	☑
2HRE-050-400-S06		40	6	80	6	☑
2HRE-050-500-S06		50	6	100	6	☑

2HRE 2-břité OSTRÉ frézy pro žebrování pro kalené oceli do HRC 60

Objednací číslo	D (mm)	L2 (mm)	L1 (mm)	L (mm)	d h5 (mm)	Standardní položka
2HRE-050-600-S06	5	60	6	100	6	<input checked="" type="checkbox"/>
2HRE-060-200-S06	6	20	10	60	6	<input checked="" type="checkbox"/>
2HRE-060-300-S06		30	10	75	6	<input checked="" type="checkbox"/>
2HRE-060-400-S06		40	10	80	6	<input checked="" type="checkbox"/>
2HRE-060-500-S06		50	10	90	6	<input checked="" type="checkbox"/>
2HRE-060-600-S06		60	10	110	6	<input checked="" type="checkbox"/>
2HRE-080-200-S08	8	20	12	65	8	<input checked="" type="checkbox"/>
2HRE-080-300-S08		30	12	80	8	<input checked="" type="checkbox"/>
2HRE-080-400-S08		40	12	100	8	<input checked="" type="checkbox"/>
2HRE-100-250-S10	10	25	15	70	10	<input checked="" type="checkbox"/>
2HRE-100-350-S10		35	15	80	10	<input checked="" type="checkbox"/>
2HRE-100-450-S10		45	15	100	10	<input checked="" type="checkbox"/>
2HRE-120-300-S12	12	30	18	80	12	<input checked="" type="checkbox"/>
2HRE-120-400-S12		40	18	100	12	<input checked="" type="checkbox"/>
2HRE-120-500-S12		50	18	120	12	<input checked="" type="checkbox"/>

J

SH

G

SUS

4HRE 4-břité OSTRÉ frézy pro žebrování pro kalené oceli do HRC 60

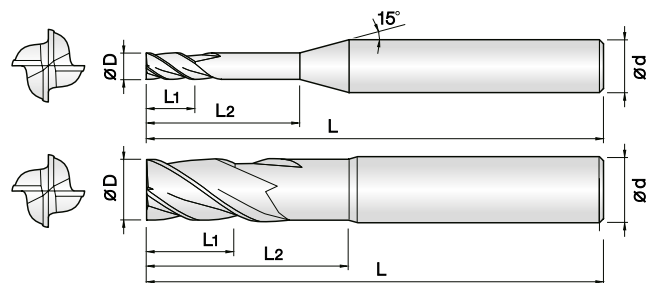

- Určeno pro kalené oceli (50–60 HRC)
- Vysoká odolnost proti opotřeby díky PVD povlaku na bázi Si
- Velmi přesné tolerance řezných hran
- Široký sortiment vyložení pro optimální výběr nástroje
- Minimalizace vyštipování díky zesílení řezné hrany
- Vynikající výkon při vysokých řezných rychlostech díky 0,2 μm tvrdokovu

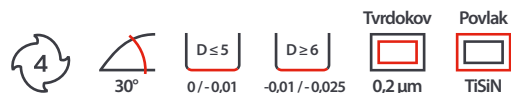

NOVINKA

Objednací číslo	D (mm)	L2 (mm)	L1 (mm)	L (mm)	d h5 (mm)	Standardní položka
4HRE-005-010-S04	0,5	1	0,5	45	4	☑
4HRE-005-020-S04		2	0,5	45	4	☑
4HRE-005-030-S04		3	0,5	45	4	☑
4HRE-005-040-S04		4	0,5	45	4	☑
4HRE-005-050-S04		5	0,5	45	4	☑
4HRE-005-060-S04		6	0,5	45	4	☑
4HRE-005-080-S04		8	0,5	45	4	☑
4HRE-005-100-S04		10	0,5	50	4	☑
4HRE-006-010-S04	0,6	1	0,6	45	4	☑
4HRE-006-020-S04		2	0,6	45	4	☑
4HRE-006-030-S04		3	0,6	45	4	☑
4HRE-006-040-S04		4	0,6	45	4	☑
4HRE-006-060-S04		6	0,6	45	4	☑
4HRE-006-080-S04		8	0,6	45	4	☑
4HRE-006-100-S04		10	0,6	50	4	☑
4HRE-006-120-S04		12	0,6	50	4	☑
4HRE-007-020-S04	0,7	2	0,7	45	4	☑
4HRE-007-040-S04		4	0,7	45	4	☑
4HRE-007-060-S04		6	0,7	45	4	☑
4HRE-007-080-S04		8	0,7	45	4	☑
4HRE-007-100-S04	10	0,7	50	4	☑	
4HRE-008-020-S04	0,8	2	0,8	45	4	☑
4HRE-008-040-S04		4	0,8	45	4	☑
4HRE-008-060-S04		6	0,8	45	4	☑
4HRE-008-080-S04		8	0,8	45	4	☑
4HRE-008-100-S04		10	0,8	45	4	☑
4HRE-008-120-S04		12	0,8	45	4	☑
4HRE-008-160-S04	16	0,8	50	4	☑	
4HRE-009-020-S04	0,9	2	0,9	45	4	☑
4HRE-009-060-S04		6	0,9	45	4	☑
4HRE-009-080-S04		8	0,9	45	4	☑
4HRE-009-100-S04	10	0,9	45	4	☑	
4HRE-010-020-S04	1	2	1	45	4	☑
4HRE-010-030-S04		3	1	45	4	☑
4HRE-010-040-S04		4	1	45	4	☑
4HRE-010-060-S04		6	1	45	4	☑
4HRE-010-080-S04		8	1	45	4	☑
4HRE-010-100-S04		10	1	45	4	☑

Objednací číslo	D (mm)	L2 (mm)	L1 (mm)	L (mm)	d h5 (mm)	Standardní položka
4HRE-010-120-S04	1	12	1	45	4	☑
4HRE-010-140-S04		14	1	50	4	☑
4HRE-010-160-S04		16	1	50	4	☑
4HRE-010-200-S04		20	1	50	4	☑
4HRE-010-250-S04		25	1	60	4	☑
4HRE-012-040-S04	1,2	4	1,2	45	4	☑
4HRE-012-060-S04		6	1,2	45	4	☑
4HRE-012-080-S04		8	1,2	45	4	☑
4HRE-012-100-S04		10	1,2	45	4	☑
4HRE-012-120-S04	12	1,2	45	4	☑	
4HRE-012-160-S04	16	1,2	50	4	☑	
4HRE-015-040-S04	1,5	4	1,5	45	4	☑
4HRE-015-060-S04		6	1,5	45	4	☑
4HRE-015-080-S04		8	1,5	45	4	☑
4HRE-015-100-S04		10	1,5	45	4	☑
4HRE-015-120-S04		12	1,5	45	4	☑
4HRE-015-160-S04		16	1,5	50	4	☑
4HRE-015-200-S04	20	1,5	50	4	☑	
4HRE-015-250-S04	25	1,5	60	4	☑	
4HRE-020-040-S04	2	4	2	45	4	☑
4HRE-020-060-S04		6	2	45	4	☑
4HRE-020-080-S04		8	2	45	4	☑
4HRE-020-100-S04		10	2	45	4	☑
4HRE-020-120-S04		12	2	45	4	☑
4HRE-020-140-S04		14	2	50	4	☑
4HRE-020-160-S04	16	2	50	4	☑	
4HRE-020-180-S04	18	2	50	4	☑	
4HRE-020-200-S04	20	2	50	4	☑	
4HRE-020-250-S04	25	2	60	4	☑	
4HRE-020-300-S04	30	2	70	4	☑	
4HRE-025-100-S04	2,5	10	2,5	45	4	☑
4HRE-025-120-S04		12	2,5	45	4	☑
4HRE-025-160-S04		16	2,5	50	4	☑
4HRE-025-200-S04		20	2,5	50	4	☑
4HRE-025-250-S04		25	2,5	60	4	☑
4HRE-025-300-S04	30	2,5	70	4	☑	
4HRE-030-060-S06	3	6	3	45	6	☑
4HRE-030-080-S06		8	3	45	6	☑

NOVINKA

Objednací číslo	D (mm)	L2 (mm)	L1 (mm)	L (mm)	d h5 (mm)	Standardní položka
4HRE-030-100-S06	3	10	3	45	6	☑
4HRE-030-120-S06		12	3	50	6	☑
4HRE-030-160-S06		16	3	55	6	☑
4HRE-030-200-S06		20	3	60	6	☑
4HRE-030-250-S06		25	3	65	6	☑
4HRE-030-300-S06		30	3	70	6	☑
4HRE-030-350-S06		35	3	75	6	☑
4HRE-030-400-S06		40	3	80	6	☑
4HRE-030-450-S06		45	3	90	6	☑
4HRE-030-500-S06		50	3	100	6	☑
4HRE-035-120-S06	3,5	12	3,5	50	6	☑
4HRE-035-160-S06		16	3,5	55	6	☑
4HRE-035-200-S06		20	3,5	60	6	☑
4HRE-035-250-S06		25	3,5	65	6	☑
4HRE-035-300-S06	30	3,5	70	6	☑	
4HRE-040-060-S06	4	6	4	50	6	☑
4HRE-040-080-S06		8	4	50	6	☑
4HRE-040-100-S06		10	4	50	6	☑
4HRE-040-120-S06		12	4	50	6	☑
4HRE-040-160-S06		16	4	55	6	☑
4HRE-040-200-S06		20	4	60	6	☑
4HRE-040-250-S06		25	4	65	6	☑
4HRE-040-300-S06		30	4	70	6	☑
4HRE-040-400-S06		40	4	80	6	☑
4HRE-040-450-S06		45	4	90	6	☑
4HRE-040-500-S06		50	4	100	6	☑
4HRE-040-600-S06		60	4	110	6	☑

Objednací číslo	D (mm)	L2 (mm)	L1 (mm)	L (mm)	d h5 (mm)	Standardní položka
4HRE-045-120-S06	4,5	12	4,5	50	6	☑
4HRE-045-160-S06		16	4,5	55	6	☑
4HRE-045-200-S06		20	4,5	60	6	☑
4HRE-045-250-S06		25	4,5	65	6	☑
4HRE-045-300-S06		30	4,5	70	6	☑
4HRE-050-160-S06		5	16	5	55	6
4HRE-050-200-S06	20		5	60	6	☑
4HRE-050-250-S06	25		5	65	6	☑
4HRE-050-300-S06	30		5	70	6	☑
4HRE-050-400-S06	40		5	80	6	☑
4HRE-050-500-S06	50		5	100	6	☑
4HRE-050-600-S06	60	5	110	6	☑	
4HRE-060-200-S06	6	20	6	60	6	☑
4HRE-060-300-S06		30	6	75	6	☑
4HRE-060-400-S06		40	6	80	6	☑
4HRE-060-500-S06		50	6	90	6	☑
4HRE-060-600-S06	60	6	110	6	☑	
4HRE-080-200-S08	8	20	10	65	8	☑
4HRE-080-300-S08		30	10	80	8	☑
4HRE-080-400-S08		40	10	100	8	☑
4HRE-100-250-S10	10	25	15	70	10	☑
4HRE-100-350-S10		35	15	90	10	☑
4HRE-100-450-S10		45	15	110	10	☑
4HRE-120-300-S12	12	30	18	80	12	☑
4HRE-120-400-S12		40	18	100	12	☑
4HRE-120-500-S12		50	18	120	12	☑

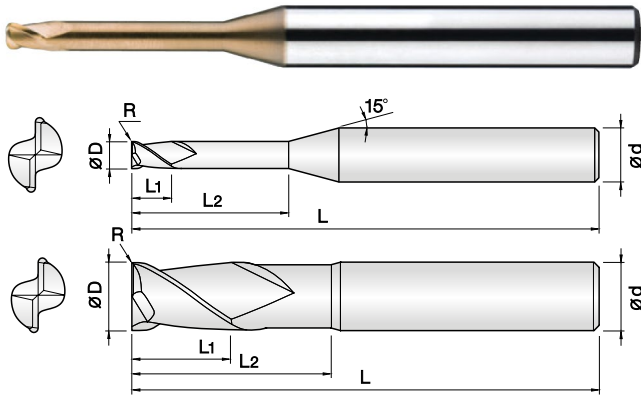

- Určeno pro kalené oceli (50–62 HRC)
- Vysoká odolnost proti opotřeбенí díky PVD povlaku na bázi Si
- Velmi přesné tolerance rezných hran
- Široký sortiment rádiusů a vyložení pro optimální výběr nástroje
- Vynikající výkon při vysokých rezných rychlostech díky 0,2 µm tvrdokovu



NOVINKA

Objednací číslo	D (mm)	R (mm)	L2 (mm)	L1 (mm)	L (mm)	d h5 (mm)	Standardní položka
2CRE-002-0002-010	0,2	R 0,02	1	0,2	40	4	☑
2CRE-002-0002-015			1,5	0,2	40	4	☑
2CRE-002-0002-020			2	0,2	40	4	☑
2CRE-002-0005-010		R 0,05	1	0,2	40	4	☑
2CRE-002-0005-015			1,5	0,2	40	4	☑
2CRE-002-0005-020			2	0,2	40	4	☑
2CRE-003-0005-010	0,3	R 0,05	1	0,3	40	4	☑
2CRE-003-0005-020			2	0,3	40	4	☑
2CRE-003-0005-030			3	0,3	40	4	☑
2CRE-003-0005-040		4	0,3	40	4	☑	
2CRE-003-0005-050		5	0,3	40	4	☑	
2CRE-004-0005-010		0,4	R 0,1	1	0,4	40	4
2CRE-004-0005-020	2			0,4	40	4	☑
2CRE-004-0005-030	3			0,4	40	4	☑
2CRE-004-0005-040	4		0,4	40	4	☑	
2CRE-004-0005-050	5		0,4	40	4	☑	
2CRE-004-0005-060	6		0,4	40	4	☑	
2CRE-004-001-010	0,5	R 0,1	1	0,4	40	4	☑
2CRE-004-001-015			1,5	0,4	40	4	☑
2CRE-004-001-020			2	0,4	40	4	☑
2CRE-004-001-030		3	0,4	40	4	☑	
2CRE-004-001-040		4	0,4	40	4	☑	
2CRE-005-0002-010		0,5	R 0,02	1	0,5	45	4
2CRE-005-0002-015	1,5			0,5	45	4	☑
2CRE-005-0002-020	2			0,5	45	4	☑
2CRE-005-0002-025	2,5			0,5	45	4	☑
2CRE-005-0002-030	3			0,5	45	4	☑
2CRE-005-0002-040	4			0,5	45	4	☑
2CRE-005-0002-050	5			0,5	45	4	☑
2CRE-005-0002-060	6		0,5	45	4	☑	
2CRE-005-0002-080	R 0,05		8	0,5	45	4	☑
2CRE-005-0002-100			10	0,5	50	4	☑
2CRE-005-0005-010			1	0,5	45	4	☑
2CRE-005-0005-015			1,5	0,5	45	4	☑
2CRE-005-0005-020			2	0,5	45	4	☑
2CRE-005-0005-025			2,5	0,5	45	4	☑
2CRE-005-0005-030		3	0,5	45	4	☑	
2CRE-005-0005-040	4	0,5	45	4	☑		

Objednací číslo	D (mm)	R (mm)	L2 (mm)	L1 (mm)	L (mm)	d h5 (mm)	Standardní položka
2CRE-005-0005-050	0,5	R 0,05	5	0,5	45	4	☑
2CRE-005-0005-060			6	0,5	45	4	☑
2CRE-005-0005-080			8	0,5	45	4	☑
2CRE-005-0005-100			10	0,5	50	4	☑
2CRE-005-0005-120			12	0,5	50	4	☑
2CRE-005-001-010			R 0,1	1	0,5	45	4
2CRE-005-001-015		1,5		0,5	45	4	☑
2CRE-005-001-020		2		0,5	45	4	☑
2CRE-005-001-025		2,5		0,5	45	4	☑
2CRE-005-001-030		3		0,5	45	4	☑
2CRE-005-001-040		4		0,5	45	4	☑
2CRE-005-001-050		R 0,2	5	0,5	45	4	☑
2CRE-005-001-060	6		0,5	45	4	☑	
2CRE-005-001-080	8		0,5	45	4	☑	
2CRE-005-001-100	10		0,5	50	4	☑	
2CRE-005-001-120	12		0,5	50	4	☑	
2CRE-006-0002-020	0,6		R 0,02	2	0,6	45	4
2CRE-006-0002-030		3		0,6	45	4	☑
2CRE-006-0002-040		4		0,6	45	4	☑
2CRE-006-0002-060		6		0,6	45	4	☑
2CRE-006-0002-080		8		0,6	45	4	☑
2CRE-006-0002-100		10		0,6	50	4	☑
2CRE-006-0005-020		R 0,05	2	0,6	45	4	☑
2CRE-006-0005-030			3	0,6	45	4	☑
2CRE-006-0005-040			4	0,6	45	4	☑
2CRE-006-0005-060			6	0,6	45	4	☑
2CRE-006-0005-080			8	0,6	45	4	☑
2CRE-006-0005-100			10	0,6	50	4	☑
2CRE-006-0005-120	R 0,1	12	0,6	50	4	☑	
2CRE-006-001-020		2	0,6	45	4	☑	
2CRE-006-001-030		3	0,6	45	4	☑	
2CRE-006-001-040		4	0,6	45	4	☑	
2CRE-006-001-060		6	0,6	45	4	☑	
2CRE-006-001-080		8	0,6	45	4	☑	
2CRE-006-001-100	0,7	10	0,6	50	4	☑	
2CRE-006-001-120		12	0,6	50	4	☑	
2CRE-007-001-020	0,7	2	0,7	45	4	☑	
2CRE-007-001-040		4	0,7	45	4	☑	

NOVINKA

Objednací číslo	D (mm)	R (mm)	L2 (mm)	L1 (mm)	L (mm)	d h5 (mm)	Standardní položka
2CRE-007-001-060	0,7	R 0,1	6	0,7	45	4	☑
2CRE-007-001-080			8	0,7	45	4	☑
2CRE-007-001-100			10	0,7	45	4	☑
2CRE-008-0002-020	0,8	R 0,02	2	0,8	45	4	☑
2CRE-008-0002-040			4	0,8	45	4	☑
2CRE-008-0002-060			6	0,8	45	4	☑
2CRE-008-0002-080		8	0,8	45	4	☑	
2CRE-008-0002-100		10	0,8	50	4	☑	
2CRE-008-0005-020		R 0,05	2	0,8	45	4	☑
2CRE-008-0005-040			4	0,8	45	4	☑
2CRE-008-0005-060			6	0,8	45	4	☑
2CRE-008-0005-080			8	0,8	45	4	☑
2CRE-008-0005-100			10	0,8	50	4	☑
2CRE-008-0005-120			12	0,8	50	4	☑
2CRE-008-001-020		R 0,1	2	0,8	45	4	☑
2CRE-008-001-040			4	0,8	45	4	☑
2CRE-008-001-060			6	0,8	45	4	☑
2CRE-008-001-080			8	0,8	45	4	☑
2CRE-008-001-100	10		0,8	50	4	☑	
2CRE-008-001-120	12		0,8	50	4	☑	
2CRE-008-001-140	14		0,8	50	4	☑	
2CRE-008-002-020	R 0,2	2	0,8	45	4	☑	
2CRE-008-002-040		4	0,8	45	4	☑	
2CRE-008-002-060		6	0,8	45	4	☑	
2CRE-008-002-080		8	0,8	45	4	☑	
2CRE-008-002-100		10	0,8	50	4	☑	
2CRE-008-002-120		12	0,8	50	4	☑	
2CRE-008-002-140	14	0,8	50	4	☑		
2CRE-010-0005-040	1	R 0,05	4	1	45	4	☑
2CRE-010-0005-060			6	1	45	4	☑
2CRE-010-0005-080			8	1	45	4	☑
2CRE-010-0005-100			10	1	50	4	☑
2CRE-010-0005-120			12	1	50	4	☑
2CRE-010-0005-140		14	1	50	4	☑	
2CRE-010-0005-160		16	1	50	4	☑	
2CRE-010-0005-200		20	1	50	4	☑	
2CRE-010-0005-220		22	1	60	4	☑	
2CRE-010-0005-250		25	1	60	4	☑	
2CRE-010-001-040		R 0,1	4	1	45	4	☑
2CRE-010-001-060			6	1	45	4	☑
2CRE-010-001-080			8	1	45	4	☑
2CRE-010-001-100			10	1	50	4	☑
2CRE-010-001-120			12	1	50	4	☑
2CRE-010-001-140	14		1	50	4	☑	
2CRE-010-001-160	16		1	50	4	☑	
2CRE-010-001-200	20		1	50	4	☑	
2CRE-010-001-220	22		1	60	4	☑	
2CRE-010-001-250	25		1	60	4	☑	
2CRE-010-002-040	R 0,2	4	1	45	4	☑	
2CRE-010-002-060		6	1	45	4	☑	
2CRE-010-002-080		8	1	45	4	☑	
2CRE-010-002-100		10	1	50	4	☑	
2CRE-010-002-100		10	1	50	4	☑	

Objednací číslo	D (mm)	R (mm)	L2 (mm)	L1 (mm)	L (mm)	d h5 (mm)	Standardní položka	
2CRE-010-002-120	1	R 0,2	12	1	50	4	☑	
2CRE-010-002-140			14	1	50	4	☑	
2CRE-010-002-160			16	1	50	4	☑	
2CRE-010-002-200			20	1	50	4	☑	
2CRE-010-002-220			22	1	60	4	☑	
2CRE-010-002-250		25	1	60	4	☑		
2CRE-010-003-040		R 0,3	4	1	45	4	☑	
2CRE-010-003-060			6	1	45	4	☑	
2CRE-010-003-080			8	1	45	4	☑	
2CRE-010-003-100			10	1	50	4	☑	
2CRE-010-003-120			12	1	50	4	☑	
2CRE-010-003-140			14	1	50	4	☑	
2CRE-010-003-160			16	1	50	4	☑	
2CRE-010-003-200			20	1	50	4	☑	
2CRE-010-003-220			22	1	60	4	☑	
2CRE-010-003-250	25		1	60	4	☑		
2CRE-012-001-040	1,2	R 0,1	4	1,2	45	4	☑	
2CRE-012-001-060			6	1,2	45	4	☑	
2CRE-012-001-080			8	1,2	45	4	☑	
2CRE-012-001-100			10	1,2	50	4	☑	
2CRE-012-001-120			12	1,2	50	4	☑	
2CRE-012-001-140		14	1,2	50	4	☑		
2CRE-012-001-160		16	1,2	50	4	☑		
2CRE-012-001-200		20	1,2	50	4	☑		
2CRE-012-002-040		R 0,2	4	1,2	45	4	☑	
2CRE-012-002-060			6	1,2	45	4	☑	
2CRE-012-002-080			8	1,2	45	4	☑	
2CRE-012-002-100			10	1,2	50	4	☑	
2CRE-012-002-120			12	1,2	50	4	☑	
2CRE-012-002-140			14	1,2	50	4	☑	
2CRE-012-002-160			16	1,2	50	4	☑	
2CRE-012-002-200	20	1,2	50	4	☑			
2CRE-012-003-040	R 0,3	4	1,2	45	4	☑		
2CRE-012-003-060		6	1,2	45	4	☑		
2CRE-012-003-080		8	1,2	45	4	☑		
2CRE-012-003-100		10	1,2	50	4	☑		
2CRE-012-003-120		12	1,2	50	4	☑		
2CRE-012-003-140		14	1,2	50	4	☑		
2CRE-012-003-160		16	1,2	50	4	☑		
2CRE-012-003-200		20	1,2	50	4	☑		
2CRE-015-001-040		1,5	R 0,1	4	1,5	45	4	☑
2CRE-015-001-060				6	1,5	45	4	☑
2CRE-015-001-080	8			1,5	45	4	☑	
2CRE-015-001-100	10			1,5	50	4	☑	
2CRE-015-001-120	12			1,5	50	4	☑	
2CRE-015-001-140	14		1,5	50	4	☑		
2CRE-015-001-160	16		1,5	50	4	☑		
2CRE-015-001-200	20		1,5	50	4	☑		
2CRE-015-001-220	22		1,5	60	4	☑		
2CRE-015-001-250	25		1,5	60	4	☑		
2CRE-015-002-040	R 0,2		4	1,5	45	4	☑	
2CRE-015-002-060			6	1,5	45	4	☑	

NOVINKA

Objednací číslo	D (mm)	R (mm)	L2 (mm)	L1 (mm)	L (mm)	d h5 (mm)	Standardní položka	
2CRE-015-002-080	1,5	R 0,2	8	1,5	45	4	☑	
2CRE-015-002-100			10	1,5	50	4	☑	
2CRE-015-002-120			12	1,5	50	4	☑	
2CRE-015-002-140			14	1,5	50	4	☑	
2CRE-015-002-160			16	1,5	50	4	☑	
2CRE-015-002-200			20	1,5	50	4	☑	
2CRE-015-002-220			22	1,5	60	4	☑	
2CRE-015-002-250			25	1,5	60	4	☑	
2CRE-015-003-040			R 0,3	4	1,5	45	4	☑
2CRE-015-003-060				6	1,5	45	4	☑
2CRE-015-003-080		8		1,5	45	4	☑	
2CRE-015-003-100		10		1,5	50	4	☑	
2CRE-015-003-120		12		1,5	50	4	☑	
2CRE-015-003-140		14		1,5	50	4	☑	
2CRE-015-003-160		16		1,5	50	4	☑	
2CRE-015-003-200		20		1,5	50	4	☑	
2CRE-015-003-220		22		1,5	60	4	☑	
2CRE-015-003-250		25		1,5	60	4	☑	
2CRE-015-005-040		R 0,5	4	1,5	45	4	☑	
2CRE-015-005-060			6	1,5	45	4	☑	
2CRE-015-005-080			8	1,5	45	4	☑	
2CRE-015-005-100			10	1,5	50	4	☑	
2CRE-015-005-120			12	1,5	50	4	☑	
2CRE-015-005-140			14	1,5	50	4	☑	
2CRE-015-005-160			16	1,5	50	4	☑	
2CRE-015-005-200			20	1,5	50	4	☑	
2CRE-015-005-220			22	1,5	60	4	☑	
2CRE-015-005-250			25	1,5	60	4	☑	
2CRE-020-001-060	2	R 0,1	6	2	45	4	☑	
2CRE-020-001-080			8	2	45	4	☑	
2CRE-020-001-100			10	2	50	4	☑	
2CRE-020-001-120			12	2	50	4	☑	
2CRE-020-001-140			14	2	50	4	☑	
2CRE-020-001-160			16	2	50	4	☑	
2CRE-020-001-200			20	2	50	4	☑	
2CRE-020-001-250			25	2	60	4	☑	
2CRE-020-001-300			30	2	70	4	☑	
2CRE-020-001-350			35	2	80	4	☑	
2CRE-020-001-400		40	2	80	4	☑		
2CRE-020-002-060		R 0,2	6	2	45	4	☑	
2CRE-020-002-080			8	2	45	4	☑	
2CRE-020-002-100			10	2	50	4	☑	
2CRE-020-002-120			12	2	50	4	☑	
2CRE-020-002-140			14	2	50	4	☑	
2CRE-020-002-160			16	2	50	4	☑	
2CRE-020-002-200			20	2	50	4	☑	
2CRE-020-002-250			25	2	60	4	☑	
2CRE-020-002-300			30	2	70	4	☑	
2CRE-020-002-060			R 0,3	6	2	45	4	☑
2CRE-020-003-080		8		2	45	4	☑	
2CRE-020-003-100		10		2	50	4	☑	
2CRE-020-003-120		12		2	50	4	☑	

Objednací číslo	D (mm)	R (mm)	L2 (mm)	L1 (mm)	L (mm)	d h5 (mm)	Standardní položka		
2CRE-020-003-140	2	R 0,3	14	2	50	4	☑		
2CRE-020-003-160			16	2	50	4	☑		
2CRE-020-003-200			20	2	50	4	☑		
2CRE-020-003-250			25	2	60	4	☑		
2CRE-020-003-300			30	2	70	4	☑		
2CRE-020-005-060			R 0,5	6	2	45	4	☑	
2CRE-020-005-080				8	2	45	4	☑	
2CRE-020-005-100				10	2	50	4	☑	
2CRE-020-005-120				12	2	50	4	☑	
2CRE-020-005-140				14	2	50	4	☑	
2CRE-020-005-160		16		2	50	4	☑		
2CRE-020-005-200		20		2	50	4	☑		
2CRE-020-005-250		25		2	60	4	☑		
2CRE-020-005-300		30		2	70	4	☑		
2CRE-020-005-350		35		2	80	4	☑		
2CRE-020-005-400		40	2	80	4	☑			
2CRE-025-001-100		2,5	R 0,1	10	2,5	50	4	☑	
2CRE-025-001-160				16	2,5	50	4	☑	
2CRE-025-001-200				20	2,5	50	4	☑	
2CRE-025-001-250				25	2,5	60	4	☑	
2CRE-025-001-300				30	2,5	70	4	☑	
2CRE-025-002-100				R 0,2	10	2,5	50	4	☑
2CRE-025-002-160					16	2,5	50	4	☑
2CRE-025-002-200					20	2,5	50	4	☑
2CRE-025-002-250					25	2,5	60	4	☑
2CRE-025-002-300					30	2,5	70	4	☑
2CRE-025-003-100			R 0,3		10	2,5	50	4	☑
2CRE-025-003-160					16	2,5	50	4	☑
2CRE-025-003-200	20				2,5	50	4	☑	
2CRE-025-003-250	25				2,5	60	4	☑	
2CRE-025-003-300	30				2,5	70	4	☑	
2CRE-025-005-100	R 0,5			10	2,5	50	4	☑	
2CRE-025-005-160				16	2,5	50	4	☑	
2CRE-025-005-200				20	2,5	50	4	☑	
2CRE-025-005-250				25	2,5	60	4	☑	
2CRE-025-005-300				30	2,5	70	4	☑	
2CRE-030-001-100			3	R 0,1	10	3	50	6	☑
2CRE-030-001-120					12	3	55	6	☑
2CRE-030-001-160					16	3	55	6	☑
2CRE-030-001-200					20	3	60	6	☑
2CRE-030-001-250					25	3	65	6	☑
2CRE-030-001-300	30				3	70	6	☑	
2CRE-030-001-350	35				3	75	6	☑	
2CRE-030-001-400	40				3	80	6	☑	
2CRE-030-002-100	R 0,2	10			3	50	6	☑	
2CRE-030-002-120		12			3	55	6	☑	
2CRE-030-002-160		16		3	55	6	☑		
2CRE-030-002-200		20		3	60	6	☑		
2CRE-030-002-250		25		3	65	6	☑		
2CRE-030-002-300		30		3	70	6	☑		
2CRE-030-002-350		35		3	75	6	☑		
2CRE-030-002-400		40		3	80	6	☑		

NOVINKA

Objednací číslo	D (mm)	R (mm)	L2 (mm)	L1 (mm)	L (mm)	d h5 (mm)	Standardní položka	
2CRE-030-002-450	3	R 0,2	45	3	90	6	☑	
2CRE-030-002-500			50	3	100	6	☑	
2CRE-030-003-100			R 0,3	10	3	50	6	☑
2CRE-030-003-120		12		3	55	6	☑	
2CRE-030-003-160		16		3	55	6	☑	
2CRE-030-003-200		20		3	60	6	☑	
2CRE-030-003-250		25		3	65	6	☑	
2CRE-030-003-300		30		3	70	6	☑	
2CRE-030-003-350		35		3	75	6	☑	
2CRE-030-003-400		40		3	80	6	☑	
2CRE-030-005-100		R 0,5		10	3	50	6	☑
2CRE-030-005-120				12	3	55	6	☑
2CRE-030-005-160			16	3	55	6	☑	
2CRE-030-005-200			20	3	60	6	☑	
2CRE-030-005-250			25	3	65	6	☑	
2CRE-030-005-300			30	3	70	6	☑	
2CRE-030-005-350			35	3	75	6	☑	
2CRE-030-005-400			40	3	80	6	☑	
2CRE-030-005-450			45	3	90	6	☑	
2CRE-030-005-500			50	3	100	6	☑	
2CRE-030-010-100		R 1	10	3	50	6	☑	
2CRE-030-010-120			12	3	55	6	☑	
2CRE-030-010-160			16	3	55	6	☑	
2CRE-030-010-200			20	3	60	6	☑	
2CRE-030-010-250			25	3	65	6	☑	
2CRE-030-010-300			30	3	70	6	☑	
2CRE-030-010-350			35	3	75	6	☑	
2CRE-030-010-400			40	3	80	6	☑	
2CRE-040-001-050			R 0,1	12	4	50	4	☑
2CRE-040-001-070				20	4	70	4	☑
2CRE-040-001-120	12	4		55	6	☑		
2CRE-040-001-160	16	4		55	6	☑		
2CRE-040-001-200	20	4		60	6	☑		
2CRE-040-001-250	25	4		65	6	☑		
2CRE-040-001-300	30	4		70	6	☑		
2CRE-040-001-350	35	4		75	6	☑		
2CRE-040-001-400	40	4		80	6	☑		
2CRE-040-001-450	45	4		90	6	☑		
2CRE-040-001-500	50	4	100	6	☑			
2CRE-040-002-050	4	R 0,2	12	4	50	4	☑	
2CRE-040-002-070			20	4	70	4	☑	
2CRE-040-002-120			12	4	55	6	☑	
2CRE-040-002-160			16	4	55	6	☑	
2CRE-040-002-200			20	4	60	6	☑	
2CRE-040-002-250			25	4	65	6	☑	
2CRE-040-002-300			30	4	70	6	☑	
2CRE-040-002-350			35	4	75	6	☑	
2CRE-040-002-400			40	4	80	6	☑	
2CRE-040-002-450			45	4	90	6	☑	
2CRE-040-002-500	50	4	100	6	☑			
2CRE-040-003-050	R 0,3	12	4	50	4	☑		
2CRE-040-003-070		20	4	70	4	☑		

Objednací číslo	D (mm)	R (mm)	L2 (mm)	L1 (mm)	L (mm)	d h5 (mm)	Standardní položka
2CRE-040-003-120	4	R 0,3	12	4	55	6	☑
2CRE-040-003-160			16	4	55	6	☑
2CRE-040-003-200			20	4	60	6	☑
2CRE-040-003-250			25	4	65	6	☑
2CRE-040-003-300			30	4	70	6	☑
2CRE-040-003-350			35	4	75	6	☑
2CRE-040-003-400			40	4	80	6	☑
2CRE-040-003-450			45	4	90	6	☑
2CRE-040-003-500			50	4	100	6	☑
2CRE-040-005-050			R 0,5	12	4	50	4
2CRE-040-005-070		20		4	70	4	☑
2CRE-040-005-120		12		4	55	6	☑
2CRE-040-005-160		16		4	55	6	☑
2CRE-040-005-200		20		4	60	6	☑
2CRE-040-005-250		25		4	65	6	☑
2CRE-040-005-300		30		4	70	6	☑
2CRE-040-005-350		35		4	75	6	☑
2CRE-040-005-400		40		4	80	6	☑
2CRE-040-005-450		45		4	90	6	☑
2CRE-040-005-500		50	4	100	6	☑	
2CRE-040-010-050		R 1	12	4	50	4	☑
2CRE-040-010-070			20	4	70	4	☑
2CRE-040-010-120			12	4	55	6	☑
2CRE-040-010-160			16	4	55	6	☑
2CRE-040-010-200			20	4	60	6	☑
2CRE-040-010-250			25	4	65	6	☑
2CRE-040-010-300			30	4	70	6	☑
2CRE-040-010-350			35	4	75	6	☑
2CRE-040-010-400			40	4	80	6	☑
2CRE-040-010-450			45	4	90	6	☑
2CRE-040-010-500	50	4	100	6	☑		
2CRE-050-002-150	5	R 0,2	15	6	60	6	☑
2CRE-050-002-250			25	6	70	6	☑
2CRE-050-002-300			30	6	70	6	☑
2CRE-050-002-400			40	6	80	6	☑
2CRE-050-002-500			50	6	100	6	☑
2CRE-050-005-150		R 0,5	15	6	60	6	☑
2CRE-050-005-250			25	6	70	6	☑
2CRE-050-005-300			30	6	70	6	☑
2CRE-050-005-400			40	6	80	6	☑
2CRE-050-005-500			50	6	100	6	☑
2CRE-050-010-150	R 1	15	6	60	6	☑	
2CRE-050-010-250		25	6	70	6	☑	
2CRE-050-010-300		30	6	70	6	☑	
2CRE-050-010-400		40	6	80	6	☑	
2CRE-050-010-500		50	6	100	6	☑	
2CRE-060-001-200	6	R 0,1	20	7	60	6	☑
2CRE-060-001-400			40	7	90	6	☑
2CRE-060-002-200		R 0,2	20	7	60	6	☑
2CRE-060-002-400			40	7	90	6	☑
2CRE-060-002-600			60	7	110	6	☑
2CRE-060-003-200		R 0,3	20	7	60	6	☑

NOVINKA

Objednací číslo	D (mm)	R (mm)	L2 (mm)	L1 (mm)	L (mm)	d h5 (mm)	Standardní položka	
2CRE-060-003-400	6	R 0,3	40	7	90	6	<input checked="" type="checkbox"/>	
2CRE-060-005-200			20	7	60	6	<input checked="" type="checkbox"/>	
2CRE-060-005-400		R 0,5	40	7	90	6	<input checked="" type="checkbox"/>	
2CRE-060-005-600			60	7	110	6	<input checked="" type="checkbox"/>	
2CRE-060-010-200		R 1	20	7	60	6	<input checked="" type="checkbox"/>	
2CRE-060-010-400			40	7	90	6	<input checked="" type="checkbox"/>	
2CRE-060-010-600			60	7	110	6	<input checked="" type="checkbox"/>	
2CRE-060-015-200		R 1,5	20	7	60	6	<input checked="" type="checkbox"/>	
2CRE-060-015-400			40	7	90	6	<input checked="" type="checkbox"/>	
2CRE-080-002-220		8	R 0,2	22	9	65	8	<input checked="" type="checkbox"/>
2CRE-080-002-400				40	9	100	8	<input checked="" type="checkbox"/>
2CRE-080-003-220			R 0,3	22	9	65	8	<input checked="" type="checkbox"/>
2CRE-080-003-400	40			9	100	8	<input checked="" type="checkbox"/>	
2CRE-080-005-220	R 0,5		22	9	65	8	<input checked="" type="checkbox"/>	
2CRE-080-005-400			40	9	100	8	<input checked="" type="checkbox"/>	
2CRE-080-005-600			60	9	120	8	<input checked="" type="checkbox"/>	
2CRE-080-010-220	R 1		22	9	65	8	<input checked="" type="checkbox"/>	
2CRE-080-010-400			40	9	100	8	<input checked="" type="checkbox"/>	
2CRE-080-010-600	60		9	120	8	<input checked="" type="checkbox"/>		
2CRE-080-015-220	R 1,5		22	9	65	8	<input checked="" type="checkbox"/>	
2CRE-080-015-400			40	9	100	8	<input checked="" type="checkbox"/>	
2CRE-100-002-240	10		R 0,2	24	11	70	10	<input checked="" type="checkbox"/>
2CRE-100-002-450				45	11	100	10	<input checked="" type="checkbox"/>
2CRE-100-002-600				60	11	120	10	<input checked="" type="checkbox"/>
2CRE-100-003-240			R 0,3	24	11	70	10	<input checked="" type="checkbox"/>
2CRE-100-003-450				45	11	100	10	<input checked="" type="checkbox"/>
2CRE-100-005-240			R 0,5	24	11	70	10	<input checked="" type="checkbox"/>
2CRE-100-005-450		45		11	100	10	<input checked="" type="checkbox"/>	
2CRE-100-005-600		60		11	120	10	<input checked="" type="checkbox"/>	
2CRE-100-010-240		R 1	24	11	70	10	<input checked="" type="checkbox"/>	
2CRE-100-010-450			45	11	100	10	<input checked="" type="checkbox"/>	
2CRE-100-010-600			60	11	120	10	<input checked="" type="checkbox"/>	
2CRE-100-015-240		R 1,5	24	11	70	10	<input checked="" type="checkbox"/>	
2CRE-100-015-450			45	11	100	10	<input checked="" type="checkbox"/>	
2CRE-100-020-240		R 2	24	11	70	10	<input checked="" type="checkbox"/>	
2CRE-100-020-450			45	11	100	10	<input checked="" type="checkbox"/>	
2CRE-120-002-260		12	R 0,2	26	13	80	12	<input checked="" type="checkbox"/>
2CRE-120-002-500				50	13	110	12	<input checked="" type="checkbox"/>
2CRE-120-003-260			R 0,3	26	13	80	12	<input checked="" type="checkbox"/>
2CRE-120-003-500				50	13	110	12	<input checked="" type="checkbox"/>
2CRE-120-005-260			R 0,5	26	13	80	12	<input checked="" type="checkbox"/>
2CRE-120-005-500	50			13	110	12	<input checked="" type="checkbox"/>	
2CRE-120-005-700	70			13	130	12	<input checked="" type="checkbox"/>	
2CRE-120-010-260	R 1		26	13	80	12	<input checked="" type="checkbox"/>	
2CRE-120-010-500			50	13	110	12	<input checked="" type="checkbox"/>	
2CRE-120-010-700			70	13	130	12	<input checked="" type="checkbox"/>	
2CRE-120-015-260	R 1,5		26	13	80	12	<input checked="" type="checkbox"/>	
2CRE-120-015-500			50	13	110	12	<input checked="" type="checkbox"/>	
2CRE-120-020-260	R 2		26	13	80	12	<input checked="" type="checkbox"/>	
2CRE-120-020-500			50	13	110	12	<input checked="" type="checkbox"/>	
2CRE-120-030-260	R 3		26	13	80	12	<input checked="" type="checkbox"/>	
2CRE-120-030-500			50	13	110	12	<input checked="" type="checkbox"/>	

Objednací číslo	D (mm)	R (mm)	L2 (mm)	L1 (mm)	L (mm)	d h5 (mm)	Standardní položka
2CRE-160-005-110	16	R 0,5	40	20	110	16	<input checked="" type="checkbox"/>
2CRE-160-005-160			60	20	160	16	<input checked="" type="checkbox"/>
2CRE-160-010-110		R 1	40	20	110	16	<input checked="" type="checkbox"/>
2CRE-160-010-160			60	20	160	16	<input checked="" type="checkbox"/>

JJ

HS

G

SUS

4CRE 4-břité TOROIDNÍ frézy pro žebrování pro kalené oceli do HRC 62

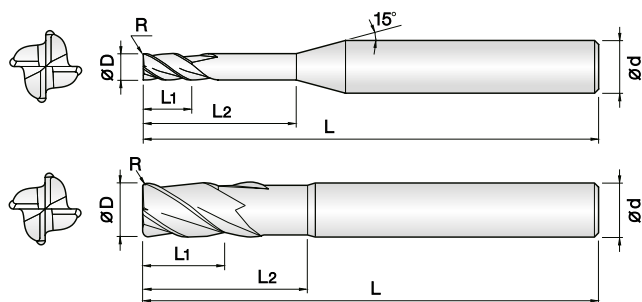

- Určeno pro kalené oceli (50–62 HRC)
- Vysoká odolnost proti opotřeby díky PVD povlaku na bázi Si
- Velmi přesné tolerance rezných hran
- Široký sortiment rádiusů a vyložení pro optimální výběr nástroje
- Vynikající výkon při vysokých rezných rychlostech díky 0,2 µm tvrdkovu v

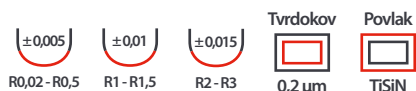
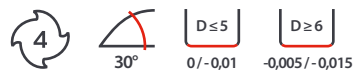

NOVINKA

Objednací číslo	D (mm)	R (mm)	L2 (mm)	L1 (mm)	L (mm)	d h5 (mm)	Standardní položka	
4CRE-008-0002-020	0,8	R 0,02	2	0,8	45	4	☑	
4CRE-008-0002-040			4	0,8	45	4	☑	
4CRE-008-0002-060			6	0,8	45	4	☑	
4CRE-008-0002-080			8	0,8	45	4	☑	
4CRE-008-0002-100			10	0,8	45	4	☑	
4CRE-008-0002-120			12	0,8	50	4	☑	
4CRE-008-0005-020		0,8	R 0,05	2	0,8	45	4	☑
4CRE-008-0005-040				4	0,8	45	4	☑
4CRE-008-0005-060				6	0,8	45	4	☑
4CRE-008-0005-080				8	0,8	45	4	☑
4CRE-008-0005-100				10	0,8	45	4	☑
4CRE-008-0005-120				12	0,8	50	4	☑
4CRE-008-001-020	1		R 0,1	2	0,8	45	4	☑
4CRE-008-001-040				4	0,8	45	4	☑
4CRE-008-001-060				6	0,8	45	4	☑
4CRE-008-001-080				8	0,8	45	4	☑
4CRE-008-001-100				10	0,8	45	4	☑
4CRE-008-001-120				12	0,8	50	4	☑
4CRE-010-0002-040		1	R 0,02	4	1	45	4	☑
4CRE-010-0002-060				6	1	45	4	☑
4CRE-010-0002-080				8	1	45	4	☑
4CRE-010-0002-100				10	1	50	4	☑
4CRE-010-0002-120				12	1	50	4	☑
4CRE-010-0002-140				14	1	50	4	☑
4CRE-010-0002-160	16			1	50	4	☑	
4CRE-010-0002-200	20			1	50	4	☑	
4CRE-010-0002-250	25			1	60	4	☑	
4CRE-010-0002-300	30		1	70	4	☑		
4CRE-010-0005-040	R 0,05		4	1	45	4	☑	
4CRE-010-0005-060			6	1	45	4	☑	
4CRE-010-0005-080			8	1	45	4	☑	
4CRE-010-0005-100			10	1	50	4	☑	
4CRE-010-0005-120			12	1	50	4	☑	
4CRE-010-0005-140			14	1	50	4	☑	
4CRE-010-0005-160			16	1	50	4	☑	
4CRE-010-0005-200			20	1	50	4	☑	
4CRE-010-0005-250		25	1	60	4	☑		
4CRE-010-0005-300	30	1	70	4	☑			

Objednací číslo	D (mm)	R (mm)	L2 (mm)	L1 (mm)	L (mm)	d h5 (mm)	Standardní položka
4CRE-010-001-040	1	R 0,1	4	1	45	4	☑
4CRE-010-001-060			6	1	45	4	☑
4CRE-010-001-080			8	1	45	4	☑
4CRE-010-001-100			10	1	50	4	☑
4CRE-010-001-120			12	1	50	4	☑
4CRE-010-001-140			14	1	50	4	☑
4CRE-010-001-160			16	1	50	4	☑
4CRE-010-001-200			20	1	50	4	☑
4CRE-010-001-250			25	1	60	4	☑
4CRE-010-001-300		30	1	70	4	☑	
4CRE-010-002-040		R 0,2	4	1	45	4	☑
4CRE-010-002-060			6	1	45	4	☑
4CRE-010-002-080			8	1	45	4	☑
4CRE-010-002-100			10	1	50	4	☑
4CRE-010-002-120			12	1	50	4	☑
4CRE-010-002-140			14	1	50	4	☑
4CRE-010-002-160			16	1	50	4	☑
4CRE-010-002-200			20	1	50	4	☑
4CRE-010-002-250	25		1	60	4	☑	
4CRE-010-002-300	30	1	70	4	☑		
4CRE-010-003-040	R 0,3	4	1	45	4	☑	
4CRE-010-003-060		6	1	45	4	☑	
4CRE-010-003-080		8	1	45	4	☑	
4CRE-010-003-100		10	1	50	4	☑	
4CRE-010-003-120		12	1	50	4	☑	
4CRE-010-003-140		14	1	50	4	☑	
4CRE-010-003-160		16	1	50	4	☑	
4CRE-010-003-200		20	1	50	4	☑	
4CRE-010-003-250		25	1	60	4	☑	
4CRE-010-003-300	30	1	70	4	☑		
4CRE-012-0002-040	1,2	R 0,02	4	1,2	45	4	☑
4CRE-012-0002-060			6	1,2	45	4	☑
4CRE-012-0002-080			8	1,2	45	4	☑
4CRE-012-0002-100			10	1,2	50	4	☑
4CRE-012-0002-120			12	1,2	50	4	☑
4CRE-012-0002-140			14	1,2	50	4	☑
4CRE-012-0002-160			16	1,2	50	4	☑
4CRE-012-0002-200			20	1,2	50	4	☑

NOVINKA

Objednací číslo	D (mm)	R (mm)	L2 (mm)	L1 (mm)	L (mm)	d h5 (mm)	Standardní položka	Objednací číslo	D (mm)	R (mm)	L2 (mm)	L1 (mm)	L (mm)	d h5 (mm)	Standardní položka
4CRE-012-0005-040	1,2	R 0,05	4	1,2	45	4	<input checked="" type="checkbox"/>	4CRE-015-001-100	1,5	R 0,1	10	1,5	50	4	<input checked="" type="checkbox"/>
4CRE-012-0005-060			6	1,2	45	4	<input checked="" type="checkbox"/>	4CRE-015-001-120			12	1,5	50	4	<input checked="" type="checkbox"/>
4CRE-012-0005-080			8	1,2	45	4	<input checked="" type="checkbox"/>	4CRE-015-001-140			14	1,5	50	4	<input checked="" type="checkbox"/>
4CRE-012-0005-100			10	1,2	50	4	<input checked="" type="checkbox"/>	4CRE-015-001-160			16	1,5	50	4	<input checked="" type="checkbox"/>
4CRE-012-0005-120			12	1,2	50	4	<input checked="" type="checkbox"/>	4CRE-015-001-200			20	1,5	50	4	<input checked="" type="checkbox"/>
4CRE-012-0005-140			14	1,2	50	4	<input checked="" type="checkbox"/>	4CRE-015-001-220			22	1,5	60	4	<input checked="" type="checkbox"/>
4CRE-012-0005-160			16	1,2	50	4	<input checked="" type="checkbox"/>	4CRE-015-001-250			25	1,5	60	4	<input checked="" type="checkbox"/>
4CRE-012-0005-200			20	1,2	50	4	<input checked="" type="checkbox"/>	4CRE-015-002-060			6	1,5	45	4	<input checked="" type="checkbox"/>
4CRE-012-001-040		R 0,1	4	1,2	45	4	<input checked="" type="checkbox"/>	4CRE-015-002-080		8	1,5	45	4	<input checked="" type="checkbox"/>	
4CRE-012-001-060			6	1,2	45	4	<input checked="" type="checkbox"/>	4CRE-015-002-100		10	1,5	50	4	<input checked="" type="checkbox"/>	
4CRE-012-001-080			8	1,2	45	4	<input checked="" type="checkbox"/>	4CRE-015-002-120		12	1,5	50	4	<input checked="" type="checkbox"/>	
4CRE-012-001-100			10	1,2	50	4	<input checked="" type="checkbox"/>	4CRE-015-002-140		14	1,5	50	4	<input checked="" type="checkbox"/>	
4CRE-012-001-120			12	1,2	50	4	<input checked="" type="checkbox"/>	4CRE-015-002-160		16	1,5	50	4	<input checked="" type="checkbox"/>	
4CRE-012-001-140			14	1,2	50	4	<input checked="" type="checkbox"/>	4CRE-015-002-200		20	1,5	50	4	<input checked="" type="checkbox"/>	
4CRE-012-001-160			16	1,2	50	4	<input checked="" type="checkbox"/>	4CRE-015-002-220		22	1,5	60	4	<input checked="" type="checkbox"/>	
4CRE-012-001-200			20	1,2	50	4	<input checked="" type="checkbox"/>	4CRE-015-002-250		25	1,5	60	4	<input checked="" type="checkbox"/>	
4CRE-012-002-040		R 0,2	4	1,2	45	4	<input checked="" type="checkbox"/>	4CRE-015-003-060		6	1,5	45	4	<input checked="" type="checkbox"/>	
4CRE-012-002-060			6	1,2	45	4	<input checked="" type="checkbox"/>	4CRE-015-003-080		8	1,5	45	4	<input checked="" type="checkbox"/>	
4CRE-012-002-080			8	1,2	45	4	<input checked="" type="checkbox"/>	4CRE-015-003-100		10	1,5	50	4	<input checked="" type="checkbox"/>	
4CRE-012-002-100			10	1,2	50	4	<input checked="" type="checkbox"/>	4CRE-015-003-120		12	1,5	50	4	<input checked="" type="checkbox"/>	
4CRE-012-002-120	12		1,2	50	4	<input checked="" type="checkbox"/>	4CRE-015-003-140	14	1,5	50	4	<input checked="" type="checkbox"/>			
4CRE-012-002-140	14		1,2	50	4	<input checked="" type="checkbox"/>	4CRE-015-003-160	16	1,5	50	4	<input checked="" type="checkbox"/>			
4CRE-012-002-160	16		1,2	50	4	<input checked="" type="checkbox"/>	4CRE-015-003-200	20	1,5	50	4	<input checked="" type="checkbox"/>			
4CRE-012-002-200	20		1,2	50	4	<input checked="" type="checkbox"/>	4CRE-015-003-220	22	1,5	60	4	<input checked="" type="checkbox"/>			
4CRE-012-003-040	R 0,3	4	1,2	45	4	<input checked="" type="checkbox"/>	4CRE-015-003-250	25	1,5	60	4	<input checked="" type="checkbox"/>			
4CRE-012-003-060		6	1,2	45	4	<input checked="" type="checkbox"/>	4CRE-015-005-060	6	1,5	45	4	<input checked="" type="checkbox"/>			
4CRE-012-003-080		8	1,2	45	4	<input checked="" type="checkbox"/>	4CRE-015-005-080	8	1,5	45	4	<input checked="" type="checkbox"/>			
4CRE-012-003-100		10	1,2	50	4	<input checked="" type="checkbox"/>	4CRE-015-005-100	10	1,5	50	4	<input checked="" type="checkbox"/>			
4CRE-012-003-120		12	1,2	50	4	<input checked="" type="checkbox"/>	4CRE-015-005-120	12	1,5	50	4	<input checked="" type="checkbox"/>			
4CRE-012-003-140		14	1,2	50	4	<input checked="" type="checkbox"/>	4CRE-015-005-140	14	1,5	50	4	<input checked="" type="checkbox"/>			
4CRE-012-003-160		16	1,2	50	4	<input checked="" type="checkbox"/>	4CRE-015-005-160	16	1,5	50	4	<input checked="" type="checkbox"/>			
4CRE-012-003-200		20	1,2	50	4	<input checked="" type="checkbox"/>	4CRE-015-005-200	20	1,5	50	4	<input checked="" type="checkbox"/>			
4CRE-015-0002-060	1,5	R 0,02	6	1,5	45	4	<input checked="" type="checkbox"/>	4CRE-015-005-220	22	1,5	60	4	<input checked="" type="checkbox"/>		
4CRE-015-0002-080			8	1,5	45	4	<input checked="" type="checkbox"/>	4CRE-015-005-250	25	1,5	60	4	<input checked="" type="checkbox"/>		
4CRE-015-0002-100			10	1,5	50	4	<input checked="" type="checkbox"/>	4CRE-020-0002-060	6	2	45	4	<input checked="" type="checkbox"/>		
4CRE-015-0002-120			12	1,5	50	4	<input checked="" type="checkbox"/>	4CRE-020-0002-080	8	2	45	4	<input checked="" type="checkbox"/>		
4CRE-015-0002-140			14	1,5	50	4	<input checked="" type="checkbox"/>	4CRE-020-0002-100	10	2	50	4	<input checked="" type="checkbox"/>		
4CRE-015-0002-160			16	1,5	50	4	<input checked="" type="checkbox"/>	4CRE-020-0002-120	12	2	50	4	<input checked="" type="checkbox"/>		
4CRE-015-0002-200			20	1,5	50	4	<input checked="" type="checkbox"/>	4CRE-020-0002-140	14	2	50	4	<input checked="" type="checkbox"/>		
4CRE-015-0002-220			22	1,5	60	4	<input checked="" type="checkbox"/>	4CRE-020-0002-160	16	2	50	4	<input checked="" type="checkbox"/>		
4CRE-015-0002-250		25	1,5	60	4	<input checked="" type="checkbox"/>	4CRE-020-0002-180	18	2	50	4	<input checked="" type="checkbox"/>			
4CRE-015-0005-060		R 0,05	6	1,5	45	4	<input checked="" type="checkbox"/>	4CRE-020-0002-200	20	2	50	4	<input checked="" type="checkbox"/>		
4CRE-015-0005-080			8	1,5	45	4	<input checked="" type="checkbox"/>	4CRE-020-0002-220	22	2	60	4	<input checked="" type="checkbox"/>		
4CRE-015-0005-100			10	1,5	50	4	<input checked="" type="checkbox"/>	4CRE-020-0002-250	25	2	60	4	<input checked="" type="checkbox"/>		
4CRE-015-0005-120			12	1,5	50	4	<input checked="" type="checkbox"/>	4CRE-020-0002-300	30	2	70	4	<input checked="" type="checkbox"/>		
4CRE-015-0005-140			14	1,5	50	4	<input checked="" type="checkbox"/>	4CRE-020-0002-350	35	2	70	4	<input checked="" type="checkbox"/>		
4CRE-015-0005-160			16	1,5	50	4	<input checked="" type="checkbox"/>	4CRE-020-0005-060	6	2	45	4	<input checked="" type="checkbox"/>		
4CRE-015-0005-200			20	1,5	50	4	<input checked="" type="checkbox"/>	4CRE-020-0005-080	8	2	45	4	<input checked="" type="checkbox"/>		
4CRE-015-0005-220			22	1,5	60	4	<input checked="" type="checkbox"/>	4CRE-020-0005-100	10	2	50	4	<input checked="" type="checkbox"/>		
4CRE-015-0005-250		25	1,5	60	4	<input checked="" type="checkbox"/>	4CRE-020-0005-120	12	2	50	4	<input checked="" type="checkbox"/>			
4CRE-015-001-060		R 0,1	6	1,5	45	4	<input checked="" type="checkbox"/>	4CRE-020-0005-140	14	2	50	4	<input checked="" type="checkbox"/>		
4CRE-015-001-080			8	1,5	45	4	<input checked="" type="checkbox"/>	4CRE-020-0005-160	16	2	50	4	<input checked="" type="checkbox"/>		

JJ

SH

G

SUS

Objednací číslo	D (mm)	R (mm)	L2 (mm)	L1 (mm)	L (mm)	d h5 (mm)	Standardní položka	
4CRE-020-0005-180	2	R 0,05	18	2	50	4	☑	
4CRE-020-0005-200			20	2	50	4	☑	
4CRE-020-0005-220			22	2	60	4	☑	
4CRE-020-0005-250			25	2	60	4	☑	
4CRE-020-0005-300			30	2	70	4	☑	
4CRE-020-0005-350			35	2	70	4	☑	
4CRE-020-001-060			R 0,1	6	2	45	4	☑
4CRE-020-001-080		8		2	45	4	☑	
4CRE-020-001-100		10		2	50	4	☑	
4CRE-020-001-120		12		2	50	4	☑	
4CRE-020-001-140		14		2	50	4	☑	
4CRE-020-001-160		16		2	50	4	☑	
4CRE-020-001-180		18		2	50	4	☑	
4CRE-020-001-200		20		2	50	4	☑	
4CRE-020-001-220		22		2	60	4	☑	
4CRE-020-001-250		25		2	60	4	☑	
4CRE-020-001-300		30		2	70	4	☑	
4CRE-020-001-350		35		2	70	4	☑	
4CRE-020-002-060		R 0,2		6	2	45	4	☑
4CRE-020-002-080				8	2	45	4	☑
4CRE-020-002-100				10	2	50	4	☑
4CRE-020-002-120				12	2	50	4	☑
4CRE-020-002-140				14	2	50	4	☑
4CRE-020-002-160				16	2	50	4	☑
4CRE-020-002-180			18	2	50	4	☑	
4CRE-020-002-200			20	2	50	4	☑	
4CRE-020-002-220			22	2	60	4	☑	
4CRE-020-002-250			25	2	60	4	☑	
4CRE-020-002-300			30	2	70	4	☑	
4CRE-020-002-350			35	2	70	4	☑	
4CRE-020-003-060		R 0,3	6	2	45	4	☑	
4CRE-020-003-080			8	2	45	4	☑	
4CRE-020-003-100			10	2	50	4	☑	
4CRE-020-003-120			12	2	50	4	☑	
4CRE-020-003-140			14	2	50	4	☑	
4CRE-020-003-160			16	2	50	4	☑	
4CRE-020-003-180			18	2	50	4	☑	
4CRE-020-003-200			20	2	50	4	☑	
4CRE-020-003-220			22	2	60	4	☑	
4CRE-020-003-250			25	2	60	4	☑	
4CRE-020-003-300			30	2	70	4	☑	
4CRE-020-003-350			35	2	70	4	☑	
4CRE-020-005-060		R 0,5	6	2	45	4	☑	
4CRE-020-005-080			8	2	45	4	☑	
4CRE-020-005-100			10	2	50	4	☑	
4CRE-020-005-120	12		2	50	4	☑		
4CRE-020-005-140	14		2	50	4	☑		
4CRE-020-005-160	16		2	50	4	☑		
4CRE-020-005-180	18		2	50	4	☑		
4CRE-020-005-200	20		2	50	4	☑		
4CRE-020-005-220	22		2	60	4	☑		
4CRE-020-005-250	25		2	60	4	☑		

Objednací číslo	D (mm)	R (mm)	L2 (mm)	L1 (mm)	L (mm)	d h5 (mm)	Standardní položka	
4CRE-020-005-300	2	R 0,5	30	2	70	4	☑	
4CRE-020-005-350			35	2	70	4	☑	
4CRE-025-001-100	2,5	R 0,1	10	2,5	50	4	☑	
4CRE-025-001-120			12	2,5	50	4	☑	
4CRE-025-001-160			16	2,5	50	4	☑	
4CRE-025-001-200			20	2,5	50	4	☑	
4CRE-025-001-250			25	2,5	60	4	☑	
4CRE-025-001-300			30	2,5	70	4	☑	
4CRE-025-002-100		R 0,2	10	2,5	50	4	☑	
4CRE-025-002-120			12	2,5	50	4	☑	
4CRE-025-002-160			16	2,5	50	4	☑	
4CRE-025-002-200			20	2,5	50	4	☑	
4CRE-025-002-250			25	2,5	60	4	☑	
4CRE-025-002-300			30	2,5	70	4	☑	
4CRE-025-003-100		R 0,3	10	2,5	50	4	☑	
4CRE-025-003-120			12	2,5	50	4	☑	
4CRE-025-003-160			16	2,5	50	4	☑	
4CRE-025-003-200			20	2,5	50	4	☑	
4CRE-025-003-250			25	2,5	60	4	☑	
4CRE-025-003-300			30	2,5	70	4	☑	
4CRE-025-005-100		R 0,5	10	2,5	50	4	☑	
4CRE-025-005-120			12	2,5	50	4	☑	
4CRE-025-005-160			16	2,5	50	4	☑	
4CRE-025-005-200			20	2,5	50	4	☑	
4CRE-025-005-250			25	2,5	60	4	☑	
4CRE-025-005-300			30	2,5	70	4	☑	
4CRE-030-001-100		3	R 0,1	10	3	50	6	☑
4CRE-030-001-120				12	3	50	6	☑
4CRE-030-001-160				16	3	55	6	☑
4CRE-030-001-200				20	3	60	6	☑
4CRE-030-001-250				25	3	65	6	☑
4CRE-030-001-300				30	3	70	6	☑
4CRE-030-001-350	R 0,2		35	3	75	6	☑	
4CRE-030-001-400			40	3	80	6	☑	
4CRE-030-001-500			50	3	100	6	☑	
4CRE-030-002-100			10	3	50	6	☑	
4CRE-030-002-120			12	3	50	6	☑	
4CRE-030-002-160			16	3	55	6	☑	
4CRE-030-002-200	R 0,3		20	3	60	6	☑	
4CRE-030-002-250			25	3	65	6	☑	
4CRE-030-002-300			30	3	70	6	☑	
4CRE-030-002-350			35	3	75	6	☑	
4CRE-030-002-400			40	3	80	6	☑	
4CRE-030-002-500			50	3	100	6	☑	
4CRE-030-003-100	R 0,5		10	3	50	6	☑	
4CRE-030-003-120			12	3	50	6	☑	
4CRE-030-003-160			16	3	55	6	☑	
4CRE-030-003-200			20	3	60	6	☑	
4CRE-030-003-250			25	3	65	6	☑	
4CRE-030-003-300			30	3	70	6	☑	
4CRE-030-003-350	35		3	75	6	☑		
4CRE-030-003-400	40		3	80	6	☑		

NOVINKA

Objednací číslo	D (mm)	R (mm)	L2 (mm)	L1 (mm)	L (mm)	d h5 (mm)	Standardní položka
4CRE-030-003-500	3	R 0,3	50	3	100	6	☑
4CRE-030-005-100		R 0,5	10	3	50	6	☑
4CRE-030-005-120			12	3	50	6	☑
4CRE-030-005-160			16	3	55	6	☑
4CRE-030-005-200			20	3	60	6	☑
4CRE-030-005-250			25	3	65	6	☑
4CRE-030-005-300			30	3	70	6	☑
4CRE-030-005-350			35	3	75	6	☑
4CRE-030-005-400			40	3	80	6	☑
4CRE-030-005-500			50	3	100	6	☑
4CRE-030-005-600			60	3	110	6	☑
4CRE-030-010-100		R 1	10	3	50	6	☑
4CRE-030-010-120			12	3	50	6	☑
4CRE-030-010-160			16	3	55	6	☑
4CRE-030-010-200			20	3	60	6	☑
4CRE-030-010-250			25	3	65	6	☑
4CRE-030-010-300			30	3	70	6	☑
4CRE-030-010-350			35	3	75	6	☑
4CRE-030-010-400			40	3	80	6	☑
4CRE-030-010-500			50	3	100	6	☑
4CRE-030-010-600	60		3	110	6	☑	
4CRE-040-001-050	4	R 0,1	12	4	50	6	☑
4CRE-040-001-070			20	4	70	6	☑
4CRE-040-001-130			13	4	55	6	☑
4CRE-040-001-160			16	4	55	6	☑
4CRE-040-001-200			20	4	60	6	☑
4CRE-040-001-250			25	4	65	6	☑
4CRE-040-001-300			30	4	70	6	☑
4CRE-040-001-350			35	4	75	6	☑
4CRE-040-001-400			40	4	80	6	☑
4CRE-040-001-450			45	4	90	6	☑
4CRE-040-001-500		50	4	100	6	☑	
4CRE-040-001-600		60	4	110	6	☑	
4CRE-040-002-050		R 0,2	12	4	50	4	☑
4CRE-040-002-070			20	4	70	4	☑
4CRE-040-002-130			13	4	55	6	☑
4CRE-040-002-160			16	4	55	6	☑
4CRE-040-002-200			20	4	60	6	☑
4CRE-040-002-250			25	4	65	6	☑
4CRE-040-002-300			30	4	70	6	☑
4CRE-040-002-350			35	4	75	6	☑
4CRE-040-002-400	40		4	80	6	☑	
4CRE-040-002-450	45		4	90	6	☑	
4CRE-040-002-500	50	4	100	6	☑		
4CRE-040-002-600	60	4	110	6	☑		
4CRE-040-003-050	R 0,3	12	4	50	4	☑	
4CRE-040-003-070		20	4	70	4	☑	
4CRE-040-003-130		13	4	55	6	☑	
4CRE-040-003-160		16	4	55	6	☑	
4CRE-040-003-200		20	4	60	6	☑	
4CRE-040-003-250		25	4	65	6	☑	
4CRE-040-003-300		30	4	70	6	☑	

Objednací číslo	D (mm)	R (mm)	L2 (mm)	L1 (mm)	L (mm)	d h5 (mm)	Standardní položka	
4CRE-040-003-350	4	R 0,3	35	4	75	6	☑	
4CRE-040-003-400			40	4	80	6	☑	
4CRE-040-003-450			45	4	90	6	☑	
4CRE-040-003-500			50	4	100	6	☑	
4CRE-040-003-600			60	4	110	6	☑	
4CRE-040-005-050			R 0,5	12	4	50	4	☑
4CRE-040-005-070		20		4	70	4	☑	
4CRE-040-005-130		13		4	55	6	☑	
4CRE-040-005-160		16		4	55	6	☑	
4CRE-040-005-200		20		4	60	6	☑	
4CRE-040-005-250		25		4	65	6	☑	
4CRE-040-005-300		30		4	70	6	☑	
4CRE-040-005-350		35		4	75	6	☑	
4CRE-040-005-400		40		4	80	6	☑	
4CRE-040-005-450		45		4	90	6	☑	
4CRE-040-005-500		50		4	100	6	☑	
4CRE-040-005-600		60		4	110	6	☑	
4CRE-040-010-050		R 1		12	4	50	4	☑
4CRE-040-010-070				20	4	70	4	☑
4CRE-040-010-130			13	4	55	6	☑	
4CRE-040-010-160	16		4	55	6	☑		
4CRE-040-010-200	20		4	60	6	☑		
4CRE-040-010-250	25		4	65	6	☑		
4CRE-040-010-300	30		4	70	6	☑		
4CRE-040-010-350	35		4	75	6	☑		
4CRE-040-010-400	40		4	80	6	☑		
4CRE-040-010-450	45		4	90	6	☑		
4CRE-040-010-500	50	4	100	6	☑			
4CRE-040-010-600	60	4	110	6	☑			
4CRE-050-001-160	5	R 0,1	16	5	60	6	☑	
4CRE-050-001-300			30	5	70	6	☑	
4CRE-050-001-400			40	5	80	6	☑	
4CRE-050-001-500		50	5	100	6	☑		
4CRE-050-002-160		R 0,2	16	5	60	6	☑	
4CRE-050-002-300	30		5	70	6	☑		
4CRE-050-002-400	40		5	80	6	☑		
4CRE-050-002-500	R 0,3	50	5	100	6	☑		
4CRE-050-003-160		16	5	60	6	☑		
4CRE-050-003-300		30	5	70	6	☑		
4CRE-050-003-400	R 0,5	40	5	80	6	☑		
4CRE-050-003-500		50	5	100	6	☑		
4CRE-050-005-160		16	5	60	6	☑		
4CRE-050-005-300	R 1	30	5	70	6	☑		
4CRE-050-005-400		40	5	80	6	☑		
4CRE-050-005-500		50	5	100	6	☑		
4CRE-050-005-600	R 1	60	5	110	6	☑		
4CRE-050-010-160		16	5	60	6	☑		
4CRE-050-010-300		30	5	70	6	☑		
4CRE-050-010-400		40	5	80	6	☑		
4CRE-050-010-500	R 1	50	5	100	6	☑		
4CRE-050-010-600		60	5	110	6	☑		
4CRE-060-001-200	6	R 0,1	20	7	60	6	☑	

NOVINKA

Objednací číslo	D (mm)	R (mm)	L2 (mm)	L1 (mm)	L (mm)	d h5 (mm)	Standardní položka	
4CRE-060-001-400	6	R 0,1	40	7	80	6	☑	
4CRE-060-001-500			50	7	100	6	☑	
4CRE-060-002-200		R 0,2	20	7	60	6	☑	
4CRE-060-002-400			40	7	80	6	☑	
4CRE-060-002-500			50	7	100	6	☑	
4CRE-060-002-600		60	7	110	6	☑		
4CRE-060-003-200		R 0,3	20	7	60	6	☑	
4CRE-060-003-400			40	7	80	6	☑	
4CRE-060-003-500			50	7	100	6	☑	
4CRE-060-005-200		R 0,5	20	7	60	6	☑	
4CRE-060-005-400			40	7	80	6	☑	
4CRE-060-005-500			50	7	100	6	☑	
4CRE-060-005-600			60	7	110	6	☑	
4CRE-060-010-200		R 1	20	7	60	6	☑	
4CRE-060-010-400			40	7	80	6	☑	
4CRE-060-010-500			50	7	100	6	☑	
4CRE-060-010-600		60	7	110	6	☑		
4CRE-060-015-200		R 1,5	20	7	60	6	☑	
4CRE-060-015-400			40	7	80	6	☑	
4CRE-060-015-500			50	7	100	6	☑	
4CRE-080-002-220		8	R 0,2	22	9	65	8	☑
4CRE-080-002-400				40	9	100	8	☑
4CRE-080-003-220			R 0,3	22	9	65	8	☑
4CRE-080-003-400				40	9	100	8	☑
4CRE-080-005-220	R 0,5		22	9	65	8	☑	
4CRE-080-005-400			40	9	100	8	☑	
4CRE-080-005-600			60	9	120	8	☑	
4CRE-080-010-220	R 1		22	9	65	8	☑	
4CRE-080-010-400			40	9	100	8	☑	
4CRE-080-010-600			60	9	120	8	☑	
4CRE-080-015-220	R 1,5		22	9	65	8	☑	
4CRE-080-015-400			40	9	100	8	☑	
4CRE-080-020-220	R 2		22	9	65	8	☑	
4CRE-080-020-400			40	9	100	8	☑	
4CRE-100-002-240	10		R 0,2	24	11	70	10	☑
4CRE-100-002-400				40	11	100	10	☑
4CRE-100-003-240			R 0,3	24	11	70	10	☑
4CRE-100-003-400				40	11	100	10	☑
4CRE-100-005-240			R 0,5	24	11	70	10	☑
4CRE-100-005-400				40	11	100	10	☑
4CRE-100-005-600				60	11	120	10	☑
4CRE-100-010-240			R 1	24	11	70	10	☑
4CRE-100-010-400				40	11	100	10	☑
4CRE-100-010-600				60	11	120	10	☑
4CRE-100-015-240		R 1,5	24	11	70	10	☑	
4CRE-100-015-400			40	11	100	10	☑	
4CRE-100-020-240		R 2	24	11	70	10	☑	
4CRE-100-020-400			40	11	100	10	☑	
4CRE-100-025-240		R 2,5	24	11	70	10	☑	
4CRE-120-003-260		12	R 0,3	26	13	80	12	☑
4CRE-120-005-260			R 0,5	26	13	80	12	☑
4CRE-120-005-400				40	13	110	12	☑

Objednací číslo	D (mm)	R (mm)	L2 (mm)	L1 (mm)	L (mm)	d h5 (mm)	Standardní položka
4CRE-120-005-600	12	R 0,5	60	13	130	12	☑
4CRE-120-010-260		R 1	26	13	80	12	☑
4CRE-120-010-400			40	13	110	12	☑
4CRE-120-010-600			60	13	130	12	☑
4CRE-120-015-260		R 1,5	26	13	80	12	☑
4CRE-120-015-400			40	13	110	12	☑
4CRE-120-020-260		R 2	26	13	80	12	☑
4CRE-120-020-400			40	13	110	12	☑
4CRE-120-030-260		R 3	26	13	80	12	☑

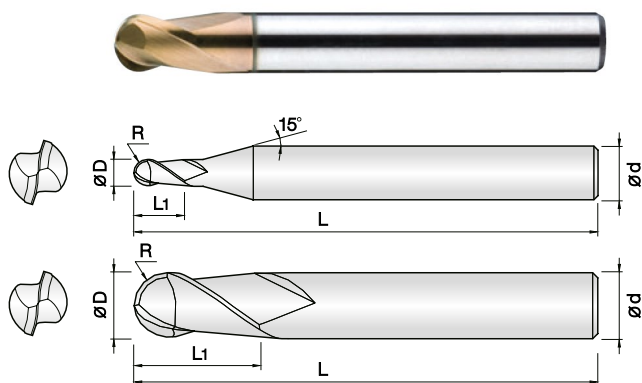

- Určeno pro kalené oceli (50–62 HRC)
- Vysoká odolnost proti opotřeby díky PVD povlaku na bázi Si
- Velmi přesné tolerance řezných hran
- Vysoká tuhost
- Vynikající výkon při vysokých řezných rychlostech díky 0,2 μm tvrdkovu

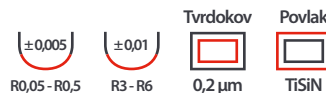
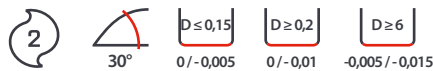

NOVINKA

Objednací číslo	D (mm)	R (mm)	L1 (mm)	L (mm)	d h5 (mm)	Standardní položka
2HSB-001-001-S04	0,1	R 0,05	0,1	40	4	☑
2HSB-001-0015-S04			0,15	40	4	☑
2HSB-0015-0015-S04	0,15	R 0,075	0,15	40	4	☑
2HSB-0015-002-S04			0,2	40	4	☑
2HSB-002-002-S04	0,2	R 0,1	0,2	40	4	☑
2HSB-002-003-S04			0,3	40	4	☑
2HSB-0025-004-S04	0,25	R 0,125	0,4	40	4	☑
2HSB-003-003-S04	0,3	R 0,15	0,3	40	4	☑
2HSB-003-0045-S04			0,45	40	4	☑
2HSB-004-004-S04	0,4	R 0,2	0,4	40	4	☑
2HSB-004-006-S04			0,6	40	4	☑
2HSB-005-005-S04	0,5	R 0,25	0,5	40	4	☑
2HSB-005-0075-S04			0,75	40	4	☑
2HSB-006-006-S04	0,6	R 0,3	0,6	40	4	☑
2HSB-006-009-S04			0,9	40	4	☑
2HSB-007-007-S04	0,7	R 0,35	0,7	40	4	☑
2HSB-007-010-S04			1	40	4	☑
2HSB-008-008-S04	0,8	R 0,4	0,8	40	4	☑
2HSB-008-012-S04			1,2	40	4	☑
2HSB-009-009-S04	0,9	R 0,45	0,9	40	4	☑
2HSB-009-013-S04			1,3	40	4	☑
2HSB-010-010-S04	1	R 0,5	1	40	4	☑
2HSB-010-010-S06			1	40	6	☑
2HSB-010-015-S04			1,5	40	4	☑
2HSB-010-015-S06			1,5	40	6	☑
2HSB-012-012-S04	1,2	R 0,6	1,2	40	4	☑
2HSB-015-015-S04	1,5	R 0,75	1,5	40	4	☑
2HSB-015-015-S06			1,5	40	6	☑
2HSB-015-023-S04			2,3	40	4	☑
2HSB-015-023-S06			2,3	40	6	☑
2HSB-020-020-S04	2	R 1	2	45	4	☑
2HSB-020-020-S06			2	45	6	☑
2HSB-020-030-S04			3	45	4	☑
2HSB-020-030-S06			3	45	6	☑
2HSB-025-025-S04	2,5	R 1,25	2,5	45	4	☑
2HSB-025-025-S06			2,5	45	6	☑
2HSB-030-030-S04	3	R 1,5	3	45	4	☑
2HSB-030-030-S06			3	45	6	☑

Objednací číslo	D (mm)	R (mm)	L1 (mm)	L (mm)	d h5 (mm)	Standardní položka
2HSB-030-045-S04	3	R 1,5	4,5	45	4	☑
2HSB-030-045-S06			4,5	45	6	☑
2HSB-040-040-S04	4	R 2	4	45	4	☑
2HSB-040-040-S06			4	45	6	☑
2HSB-040-060-S04	4	R 2	6	45	4	☑
2HSB-040-060-S06			6	45	6	☑
2HSB-050-050-S06	5	R 2,5	5	50	6	☑
2HSB-050-075-S06			7,5	50	6	☑
2HSB-060-060-050	6	R 3	6	50	6	☑
2HSB-060-060-060			6	60	6	☑
2HSB-080-080-050	8	R 4	8	50	8	☑
2HSB-080-080-060			8	60	8	☑
2HSB-100-100-060	10	R 5	10	60	10	☑
2HSB-100-100-070			10	70	10	☑
2HSB-120-120-060	12	R 6	12	60	12	☑
2HSB-120-120-070			12	70	12	☑

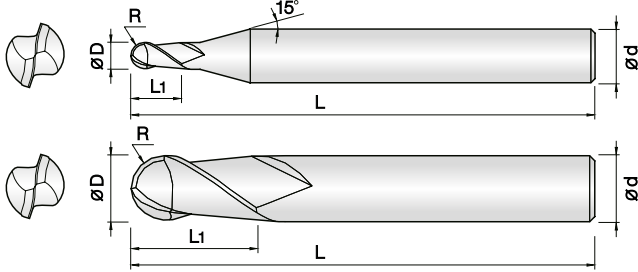

- Určeno pro kalené oceli (50–62 HRC)
- Vysoká odolnost proti opotřebování díky PVD povlaku na bázi Si
- Velmi přesné tolerance řezných hran
- Vysoká kvalita obrobeného povrchu
- Vynikající výkon při vysokých řezných rychlostech díky 0,2 μm tvrdokovu

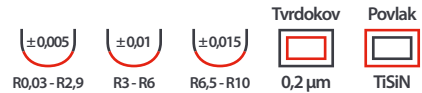
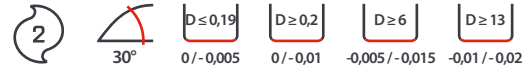

Objednací číslo	D (mm)	R (mm)	L1 (mm)	L (mm)	d h5 (mm)	Standardní položka
2HCB-0006-001-S04	0,06	R 0,03	0,1	40	4	☑
2HCB-0007-0012-S04	0,07	R 0,035	0,12	40	4	☑
2HCB-0008-0015-S04	0,08	R 0,04	0,15	40	4	☑
2HCB-0009-0017-S04	0,09	R 0,045	0,17	40	4	☑
2HCB-001-002-S04	0,1	R 0,05	0,2	40	4	☑
2HCB-0015-003-S04	0,15	R 0,075	0,3	40	4	☑
2HCB-002-004-S04	0,2	R 0,1	0,4	40	4	☑
2HCB-003-006-S04	0,3	R 0,15	0,6	40	4	☑
2HCB-004-008-S04	0,4	R 0,2	0,8	40	4	☑
2HCB-005-010-S04	0,5	R 0,25	1	45	4	☑
2HCB-006-012-S04	0,6	R 0,3	1,2	45	4	☑
2HCB-007-015-S04	0,7	R 0,35	1,5	45	4	☑
2HCB-008-020-S04	0,8	R 0,4	2	45	4	☑
2HCB-009-020-S04	0,9	R 0,45	2	45	4	☑
2HCB-010-025-S03	1	R 0,5	2,5	50	3	☑
2HCB-010-025-S04			2,5	50	4	☑
2HCB-010-025-S06			2,5	50	6	☑
2HCB-010-025-070			2,5	70	6	☑
2HCB-010-025-100			2,5	100	6	☑
2HCB-011-027-S04	1,1	R 0,55	2,7	50	4	☑
2HCB-012-030-S03	1,2	R 0,6	3	50	3	☑
2HCB-012-030-S04			3	50	4	☑
2HCB-013-032-S04	1,3	R 0,65	3,2	50	4	☑
2HCB-014-035-S04	1,4	R 0,7	3,5	50	4	☑
2HCB-015-040-S03	1,5	R 0,75	4	50	3	☑
2HCB-015-040-S04			4	50	4	☑
2HCB-015-040-S06			4	50	6	☑
2HCB-015-040-070			4	70	6	☑
2HCB-015-040-100			4	100	6	☑
2HCB-016-040-S04	1,6	R 0,8	4	50	4	☑
2HCB-017-042-S04	1,7	R 0,85	4,2	50	4	☑
2HCB-018-045-S04	1,8	R 0,9	4,5	50	4	☑
2HCB-019-047-S04	1,9	R 0,95	4,7	50	4	☑
2HCB-020-050-S03	2	R 1	5	50	3	☑
2HCB-020-050-S04			5	50	4	☑
2HCB-020-050-S06			5	50	6	☑
2HCB-020-050-075			5	75	6	☑
2HCB-020-050-100			5	100	6	☑

Objednací číslo	D (mm)	R (mm)	L1 (mm)	L (mm)	d h5 (mm)	Standardní položka
2HCB-022-055-S04	2,2	R 1,1	5,5	50	4	☑
2HCB-024-060-S04	2,4	R 1,2	6	50	4	☑
2HCB-025-060-S03	2,5	R 1,25	6	50	3	☑
2HCB-025-060-S04			6	50	4	☑
2HCB-025-060-S06			6	75	6	☑
2HCB-025-060-100			6	100	6	☑
2HCB-026-060-S04	2,6	R 1,3	6	50	4	☑
2HCB-028-070-S04	2,8	R 1,4	7	50	4	☑
2HCB-030-080-S03	3	R 1,5	8	60	3	☑
2HCB-030-080-S04			8	50	4	☑
2HCB-030-080-S06			8	60	6	☑
2HCB-030-080-080			8	80	6	☑
2HCB-030-080-100			8	100	6	☑
2HCB-032-080-S04	3,2	R 1,6	8	60	4	☑
2HCB-034-080-S04	3,4	R 1,7	8	60	4	☑
2HCB-035-080-S06	3,5	R 1,75	8	60	6	☑
2HCB-036-090-S04	3,6	R 1,8	9	60	4	☑
2HCB-038-090-S04	3,8	R 1,9	9	60	4	☑
2HCB-040-080-060	4	R 2	8	60	4	☑
2HCB-040-080-080			8	80	4	☑
2HCB-040-080-S06			8	70	6	☑
2HCB-040-080-090			8	90	6	☑
2HCB-040-080-120	8	120	6	☑		
2HCB-042-100-S06	4,2	R 2,1	10	70	6	☑
2HCB-044-100-S06	4,4	R 2,2	10	70	6	☑
2HCB-045-080-S06	4,5	R 2,25	8	70	6	☑
2HCB-046-100-S06	4,6	R 2,3	10	70	6	☑
2HCB-048-110-S06	4,8	R 2,4	11	70	6	☑
2HCB-050-080-S05	5	R 2,5	8	80	5	☑
2HCB-050-100-S06			10	75	6	☑
2HCB-052-120-S06	5,2	R 2,6	12	75	6	☑
2HCB-054-120-S06	5,4	R 2,7	12	75	6	☑
2HCB-055-100-S06	5,5	R 2,75	10	75	6	☑
2HCB-056-120-S06	5,6	R 2,8	12	75	6	☑
2HCB-058-120-S06	5,8	R 2,9	12	75	6	☑
2HCB-060-100-060	6	R 3	10	60	6	☑
2HCB-060-120-080			12	80	6	☑
2HCB-060-120-100			12	100	6	☑

2HCB 2-břité KULOVÉ frézy pro kalené oceli do HRC 62

Objednací číslo	D (mm)	R (mm)	L1 (mm)	L (mm)	d h5 (mm)	Standardní položka
2HCB-060-120-120	6	R 3	12	120	6	<input checked="" type="checkbox"/>
2HCB-060-120-150			12	150	6	<input checked="" type="checkbox"/>
2HCB-070-140-508	7	R 3,5	14	80	8	<input checked="" type="checkbox"/>
2HCB-080-140-090	8	R 4	14	90	8	<input checked="" type="checkbox"/>
2HCB-080-140-110			14	110	8	<input checked="" type="checkbox"/>
2HCB-080-140-150			14	150	8	<input checked="" type="checkbox"/>
2HCB-090-160-510	9	R 4,5	16	100	10	<input checked="" type="checkbox"/>
2HCB-100-180-100	10	R 5	18	100	10	<input checked="" type="checkbox"/>
2HCB-100-180-120			18	120	10	<input checked="" type="checkbox"/>
2HCB-100-180-150			18	150	10	<input checked="" type="checkbox"/>
2HCB-100-180-180			18	180	10	<input checked="" type="checkbox"/>
2HCB-110-200-512	11	R 5,5	20	110	12	<input checked="" type="checkbox"/>
2HCB-120-220-110	12	R 6	22	110	12	<input checked="" type="checkbox"/>
2HCB-120-220-130			22	130	12	<input checked="" type="checkbox"/>
2HCB-120-220-150			22	150	12	<input checked="" type="checkbox"/>
2HCB-120-220-200			22	200	12	<input checked="" type="checkbox"/>
2HCB-130-240-514	13	R 6,5	24	110	14	<input checked="" type="checkbox"/>
2HCB-140-240-514	14	R 7	24	110	14	<input checked="" type="checkbox"/>
2HCB-160-300-130	16	R 8	30	130	16	<input checked="" type="checkbox"/>
2HCB-160-300-160			30	160	16	<input checked="" type="checkbox"/>
2HCB-160-300-200			30	200	16	<input checked="" type="checkbox"/>
2HCB-200-380-160	20	R 10	38	160	20	<input checked="" type="checkbox"/>
2HCB-200-380-200			38	200	20	<input checked="" type="checkbox"/>

JJ

HS

G

SUS

2PHCB 2-břité KULOVÉ frézy ultrapřesné ($\pm 2 \mu\text{m}$) pro kalené oceli do HRC 62

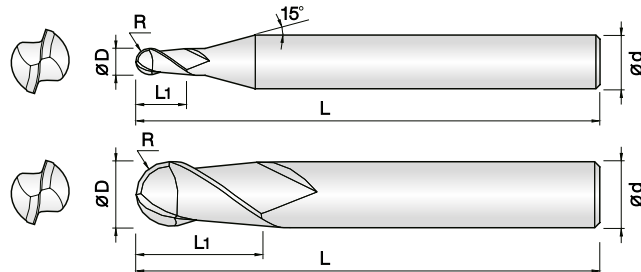

- ▶ Určeno pro kalené oceli (50–62 HRC)
- ▶ Vysoká odolnost proti opotřebení díky PVD povlaku na bázi Si
- ▶ Velmi přesné tolerance řezných hran
- ▶ Vysoká kvalita obrobeného povrchu
- ▶ Vynikající výkon při vysokých řezných rychlostech díky 0,2 μm tvrdkovu

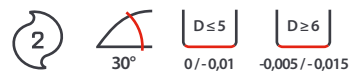

Objednací číslo	D (mm)	R (mm)	L1 (mm)	L (mm)	d h5 (mm)	Standardní položka
2PHCB-002-004-S04	0,2	R 0,1	0,4	40	4	☑
2PHCB-003-006-S04	0,3	R 0,15	0,6	40	4	☑
2PHCB-004-008-S04	0,4	R 0,2	0,8	40	4	☑
2PHCB-005-010-S04	0,5	R 0,25	1	45	4	☑
2PHCB-006-012-S04	0,6	R 0,3	1,2	45	4	☑
2PHCB-007-015-S04	0,7	R 0,35	1,5	45	4	☑
2PHCB-008-020-S04	0,8	R 0,4	2	45	4	☑
2PHCB-009-020-S04	0,9	R 0,45	2	45	4	☑
2PHCB-010-025-S04	1	R 0,5	2,5	50	4	☑
2PHCB-010-025-S06			2,5	50	6	☑
2PHCB-012-030-S04	1,2	R 0,6	3	50	4	☑
2PHCB-015-040-S04	1,5	R 0,75	4	50	4	☑
2PHCB-015-040-S06			4	50	6	☑
2PHCB-020-050-S04	2	R 1	5	50	4	☑
2PHCB-020-050-S06			5	50	6	☑
2PHCB-025-060-S04	2,5	R 1,25	6	50	4	☑
2PHCB-030-080-S04	3	R 1,5	8	50	4	☑
2PHCB-030-080-S06			8	60	6	☑
2PHCB-035-080-S06	3,5	R 1,75	8	60	6	☑
2PHCB-040-080-S04	4	R 2	8	60	4	☑
2PHCB-040-080-S06			8	70	6	☑
2PHCB-045-080-S06	4,5	R 2,25	8	70	6	☑
2PHCB-050-100-S06	5	R 2,5	10	75	6	☑
2PHCB-055-100-S06	5,5	R 2,75	10	75	6	☑
2PHCB-060-120-080	6	R 3	12	80	6	☑
2PHCB-070-140-S08	7	R 3,5	14	80	8	☑
2PHCB-080-140-090	8	R 4	14	90	8	☑
2PHCB-100-180-100	10	R 5	18	100	10	☑
2PHCB-120-220-110	12	R 6	22	110	12	☑

3HCB

3-břité KULOVÉ frézy pro kalené oceli do HRC 62

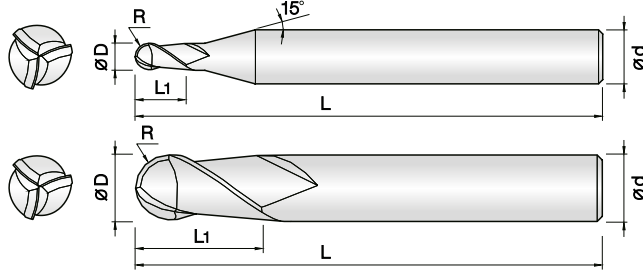

- ▶ Určeno pro kalené oceli (50–62 HRC)
- ▶ Vysoká odolnost proti opotřebení díky PVD povlaku na bázi Si
- ▶ Velmi přesné tolerance řezných hran
- ▶ Vyšší posuvy díky 3 řezným hranám
- ▶ Vynikající výkon při vysokých řezných rychlostech díky 0,2 μm tvrdokovu

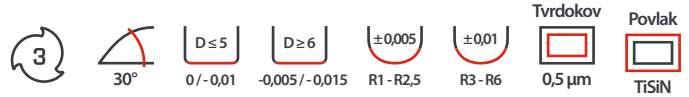

NOVINKA

Objednací číslo	D (mm)	R (mm)	L1 (mm)	L (mm)	d h5 (mm)	Standardní položka
3HCB-010-025-S04	1	R 0,5	2,5	50	4	☑
3HCB-015-040-S04	1,5	R 0,75	4	50	4	☑
3HCB-020-050-S06	2	R 1	5	50	6	☑
3HCB-030-080-S06	3	R 1,5	8	65	6	☑
3HCB-040-080-S04	4	R 2	8	60	4	☑
3HCB-040-080-S06			8	70	6	☑
3HCB-050-100-S06	5	R 2,5	10	75	6	☑
3HCB-060-120-S06	6	R 3	12	80	6	☑
3HCB-060-120-120	6	R 3	12	120	6	☑
3HCB-080-140-S08	8	R 4	14	90	8	☑
3HCB-080-140-150			14	150	8	☑
3HCB-100-180-S10	10	R 5	18	100	10	☑
3HCB-100-180-150			18	150	10	☑
3HCB-120-220-S12	12	R 6	22	110	12	☑
3HCB-120-220-150			22	150	12	☑

4HCB 4-břité KULOVÉ frézy pro kalené oceli do HRC 62

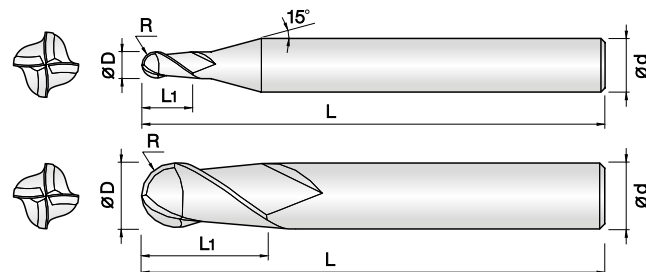

- ▶ Určeno pro kalené oceli (50–62 HRC)
- ▶ Vysoká odolnost proti opotřebení díky PVD povlaku na bázi Si
- ▶ Velmi přesné tolerance řezných hran
- ▶ Vyšší posuvy díky 4 řezným hranám
- ▶ Vynikající výkon při vysokých řezných rychlostech díky 0,2 μm tvrdokovu

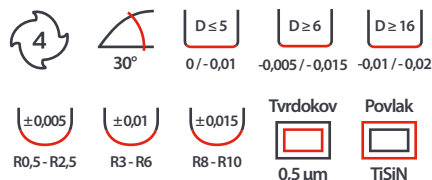

NOVINKA

Objednací číslo	D (mm)	R (mm)	L1 (mm)	L (mm)	d h5 (mm)	Standardní položka
4HCB-010-025-S06	1	R 0,5	2,5	50	6	☑
4HCB-010-025-080			2,5	80	6	☑
4HCB-015-040-S06	1,5	R 0,75	4	50	6	☑
4HCB-015-040-080			4	80	6	☑
4HCB-020-050-S06	2	R 1	5	50	6	☑
4HCB-020-050-080		5	80	6	☑	
4HCB-025-070-S06	2,5	R 1,25	7	50	6	☑
4HCB-025-070-080			7	80	6	☑
4HCB-030-080-S06	3	R 1,5	8	60	6	☑
4HCB-030-080-090			8	90	6	☑
4HCB-040-080-S04	4	R 2	8	60	4	☑
4HCB-040-080-090			8	90	4	☑
4HCB-040-080-S06			8	70	6	☑
4HCB-040-080-100			8	100	6	☑
4HCB-050-100-S06	5	R 2,5	10	80	6	☑
4HCB-050-100-110			10	110	6	☑
4HCB-060-120-S06	6	R 3	12	90	6	☑
4HCB-060-120-110			12	110	6	☑
4HCB-080-140-S08	8	R 4	14	100	8	☑
4HCB-080-140-150			14	150	8	☑
4HCB-100-180-S10	10	R 5	18	100	10	☑
4HCB-100-180-150			18	150	10	☑
4HCB-120-220-S12	12	R 6	22	110	12	☑
4HCB-120-220-150			22	150	12	☑
4HCB-140-240-110	14	R 7	24	110	14	☑
4HCB-160-300-S16	16	R 8	30	130	16	☑
4HCB-160-300-160			30	160	16	☑
4HCB-200-400-S20	20	R 10	40	160	20	☑
4HCB-200-400-200			40	200	20	☑

4HSB 4-břité KULOVÉ frézy vysokorychlostní s krátkou délkou

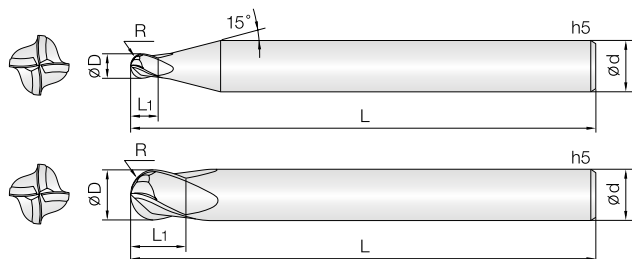

- ▶ Určeno pro kalené oceli (50–62 HRC)
- ▶ Vysoká odolnost proti opotřeбенí díky PVD povlaku na bázi Si
- ▶ Velmi přesné tolerance řezných hran
- ▶ Krátká celková délka pro snadné použití v tepelném upínací
- ▶ Vysoká produktivita obrábění díky čtyřem břitům
- ▶ Vynikající výkon při vysokých řezných rychlostech díky 0,2 μm tvrdokovu

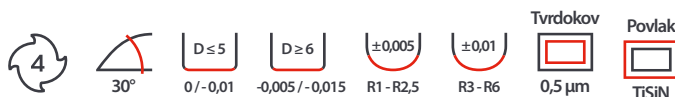

NOVINKA

Objednací číslo	D (mm)	R (mm)	L1 (mm)	L (mm)	d h5 (mm)	Standardní položka
4HSB-010-012-S04	1	R 0,5	1,2	40	4	☑
4HSB-012-015-S04	1,2	R 0,6	1,5	40	4	☑
4HSB-015-018-S04	1,5	R 0,75	1,8	40	4	☑
4HSB-020-024-S04	2	R 1	2,4	40	4	☑
4HSB-025-030-S04	2,5	R 1,25	3	45	4	☑
4HSB-030-036-S06	3	R 1,5	3,6	45	6	☑
4HSB-040-050-S04	4	R 2	5	45	4	☑
4HSB-040-050-S06	4	R 2	5	45	6	☑
4HSB-050-060-S06	5	R 2,5	6	50	6	☑
4HSB-060-070-S06	6	R 3	7	50	6	☑
4HSB-060-070-060	6	R 3	7	60	6	☑
4HSB-080-080-S08	8	R 4	8	60	8	☑
4HSB-100-100-S10	10	R 5	10	60	10	☑
4HSB-120-120-S12	12	R 6	12	75	12	☑

2HSE 2-břité OSTRÉ frézy krátké pro kalené oceli do HRC 60

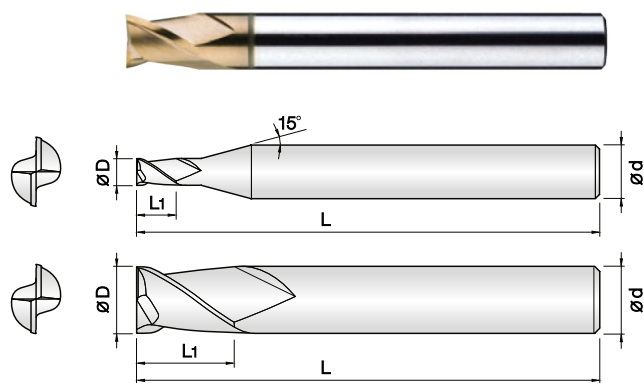

- ▶ **Určeno pro kalené oceli (50–60 HRC)**
- ▶ Vysoká odolnost proti opotřebení díky PVD povlaku na bázi Si
- ▶ Velmi přesné tolerance řezných hran
- ▶ Minimalizace vyštípování díky zesílení řezné hrany
- ▶ Vysoká tuhost
- ▶ Vynikající výkon při vysokých řezných rychlostech díky 0,2 μm tvrdokovu

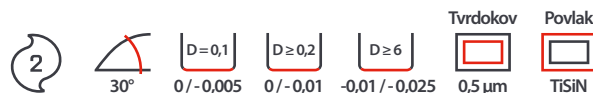

NOVINKA

Objednací číslo	D (mm)	L1 (mm)	L (mm)	d h5 (mm)	Standardní položka
2HSE-001-001-S04	0,1	0,1	40	4	☑
2HSE-0015-0015-S04	0,15	0,15	40	4	☑
2HSE-002-002-S04	0,2	0,2	40	4	☑
2HSE-0025-0025-S04	0,25	0,25	40	4	☑
2HSE-003-003-S04	0,3	0,3	40	4	☑
2HSE-004-004-S04	0,4	0,4	40	4	☑
2HSE-005-005-S04	0,5	0,5	40	4	☑
2HSE-006-006-S04	0,6	0,6	40	4	☑
2HSE-007-007-S04	0,7	0,7	40	4	☑
2HSE-008-008-S04	0,8	0,8	40	4	☑
2HSE-009-009-S04	0,9	0,9	40	4	☑
2HSE-010-010-S04	1	1	40	4	☑
2HSE-012-012-S04	1,2	1,2	40	4	☑
2HSE-015-015-S04	1,5	1,5	40	4	☑
2HSE-020-020-S04	2	2	40	4	☑
2HSE-030-030-S04	3	3	40	4	☑
2HSE-040-040-S04	4	4	40	4	☑
2HSE-050-050-S06	5	5	45	6	☑
2HSE-060-060-S06	6	6	45	6	☑
2HSE-080-080-S08	8	8	50	8	☑
2HSE-100-100-S10	10	10	60	10	☑
2HSE-120-120-S12	12	12	65	12	☑

2HCE 2-břité OSTRÉ frézy pro kalené oceli do HRC 60

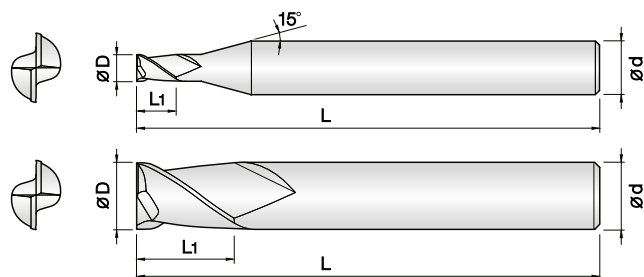

- ▶ **Určeno pro kalené oceli (50–60 HRC)**
- ▶ Vysoká odolnost proti opotřebování díky PVD povlaku na bázi Si
- ▶ Velmi přesné tolerance řezných hran
- ▶ Minimalizace vyštípování díky zesílení řezné hrany
- ▶ Vynikající výkon při vysokých řezných rychlostech díky 0,2 μm tvrdokovu

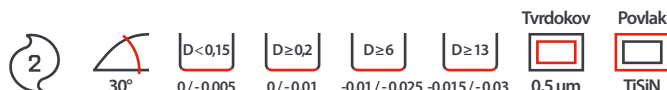

NOVINKA

Objednací číslo	D (mm)	L1 (mm)	L (mm)	d h5 (mm)	Standardní položka
2HCE-0005-0008-S04	0,05	0,08	40	4	☑
2HCE-0006-001-S04	0,06	0,1	40	4	☑
2HCE-0007-0012-S04	0,07	0,12	40	4	☑
2HCE-0008-0015-S04	0,08	0,15	40	4	☑
2HCE-0009-0017-S04	0,09	0,17	40	4	☑
2HCE-001-002-S04	0,1	0,2	40	4	☑
2HCE-0015-003-S04	0,15	0,3	40	4	☑
2HCE-002-004-S04	0,2	0,4	40	4	☑
2HCE-0025-005-S04	0,25	0,5	40	4	☑
2HCE-003-006-S04	0,3	0,6	40	4	☑
2HCE-0035-007-S04	0,35	0,7	40	4	☑
2HCE-004-008-S04	0,4	0,8	40	4	☑
2HCE-0045-009-S04	0,45	0,9	40	4	☑
2HCE-005-010-S03	0,5	1	40	3	☑
2HCE-005-010-S04		1	40	4	☑
2HCE-0055-011-S04	0,55	1,1	40	4	☑
2HCE-006-012-S03	0,6	1,2	40	3	☑
2HCE-006-012-S04		1,2	40	4	☑
2HCE-0065-013-S04	0,65	1,3	40	4	☑
2HCE-007-014-S04	0,7	1,4	40	4	☑
2HCE-0075-015-S04	0,75	1,5	40	4	☑
2HCE-008-016-S03	0,8	1,6	40	3	☑
2HCE-008-016-S04	0,8	1,6	40	4	☑
2HCE-0085-017-S04	0,85	1,7	40	4	☑
2HCE-009-020-S04	0,9	2	40	4	☑
2HCE-0095-020-S04	0,95	2	40	4	☑
2HCE-010-025-S03	1	2,5	40	3	☑
2HCE-010-025-S04		2,5	40	4	☑
2HCE-010-025-S06		2,5	40	6	☑
2HCE-010-025-060		2,5	60	6	☑
2HCE-0105-025-S04	1,05	2,5	40	4	☑
2HCE-011-027-S04	1,1	2,7	40	4	☑
2HCE-0115-025-S04	1,15	2,5	40	4	☑
2HCE-012-030-S03	1,2	3	40	3	☑
2HCE-012-030-S04		3	40	4	☑
2HCE-012-030-060		3	60	6	☑
2HCE-0125-030-S04	1,25	3	40	4	☑
2HCE-013-032-S04	1,3	3,2	40	4	☑

Objednací číslo	D (mm)	L1 (mm)	L (mm)	d h5 (mm)	Standardní položka
2HCE-0135-032-S04	1,35	3,2	40	4	☑
2HCE-014-035-S04	1,4	3,5	40	4	☑
2HCE-0145-035-S04	1,45	3,5	40	4	☑
2HCE-015-040-S03	1,5	4	40	3	☑
2HCE-015-040-S04		4	40	4	☑
2HCE-015-040-S06		4	40	6	☑
2HCE-015-040-060		4	60	6	☑
2HCE-0155-040-S04	1,55	4	40	4	☑
2HCE-016-040-S04	1,6	4	40	4	☑
2HCE-0165-040-S04	1,65	4	40	4	☑
2HCE-017-042-S04	1,7	4,2	40	4	☑
2HCE-0175-042-S04	1,75	4,2	40	4	☑
2HCE-018-045-S04	1,8	4,5	40	4	☑
2HCE-0185-045-S04	1,85	4,5	40	4	☑
2HCE-019-050-S04	1,9	5	40	4	☑
2HCE-0195-050-S04	1,95	5	40	4	☑
2HCE-020-060-S03	2	6	40	3	☑
2HCE-020-060-S04		6	40	4	☑
2HCE-020-060-S06		6	40	6	☑
2HCE-020-060-060		6	60	6	☑
2HCE-021-060-S04	2,1	6	40	4	☑
2HCE-022-060-S04	2,2	6	40	4	☑
2HCE-023-060-S04	2,3	6	40	4	☑
2HCE-024-080-S04	2,4	8	45	4	☑
2HCE-025-080-S03	2,5	8	45	3	☑
2HCE-025-080-S04	2,5	8	45	4	☑
2HCE-025-080-S06	2,5	8	45	6	☑
2HCE-025-080-070	2,5	8	70	6	☑
2HCE-026-080-S04	2,6	8	45	4	☑
2HCE-027-080-S04	2,7	8	45	4	☑
2HCE-028-080-S04	2,8	8	45	4	☑
2HCE-029-080-S04	2,9	8	45	4	☑
2HCE-030-080-S03	3	8	45	3	☑
2HCE-030-080-S04		8	45	4	☑
2HCE-030-080-S06		8	45	6	☑
2HCE-030-080-070		8	70	6	☑
2HCE-031-080-S06	3,1	8	45	6	☑
2HCE-032-080-S06	3,2	8	45	6	☑

Objednací číslo	D (mm)	L1 (mm)	L (mm)	d h5 (mm)	Standardní položka
2HCE-033-080-S06	3,3	8	45	6	☑
2HCE-034-080-S06	3,4	8	45	6	☑
2HCE-035-100-S06	3,5	10	45	6	☑
2HCE-036-100-S06	3,6	10	45	6	☑
2HCE-037-100-S06	3,7	10	45	6	☑
2HCE-038-100-S06	3,8	10	45	6	☑
2HCE-039-100-S06	3,9	10	45	6	☑
2HCE-040-100-S04	4	10	45	4	☑
2HCE-040-110-S06		11	45	6	☑
2HCE-040-110-070		11	70	6	☑
2HCE-041-110-S06	4,1	11	45	6	☑
2HCE-042-110-S06	4,2	11	45	6	☑
2HCE-043-110-S06	4,3	11	45	6	☑
2HCE-044-110-S06	4,4	11	45	6	☑
2HCE-045-110-S06	4,5	11	45	6	☑
2HCE-046-110-S06	4,6	11	45	6	☑
2HCE-047-110-S06	4,7	11	45	6	☑
2HCE-048-110-S06	4,8	11	45	6	☑
2HCE-049-110-S06	4,9	11	45	6	☑
2HCE-050-130-S06	5	13	50	6	☑
2HCE-050-130-080		13	80	6	☑
2HCE-051-130-S06	5,1	13	50	6	☑
2HCE-052-130-S06	5,2	13	50	6	☑
2HCE-053-130-S06	5,3	13	50	6	☑
2HCE-054-130-S06	5,4	13	50	6	☑
2HCE-055-130-S06	5,5	13	50	6	☑
2HCE-056-130-S06	5,6	13	50	6	☑
2HCE-057-130-S06	5,7	13	50	6	☑
2HCE-058-130-S06	5,8	13	50	6	☑
2HCE-059-130-S06	5,9	13	50	6	☑
2HCE-060-130-S06	6	13	50	6	☑
2HCE-060-130-080		13	80	6	☑
2HCE-061-150-S08	6,1	15	70	8	☑
2HCE-062-150-S08	6,2	15	70	8	☑
2HCE-063-150-S08	6,3	15	70	8	☑
2HCE-064-150-S08	6,4	15	70	8	☑
2HCE-065-160-S08	6,5	16	60	8	☑
2HCE-070-160-S08	7	16	60	8	☑
2HCE-075-160-S08	7,5	16	60	8	☑
2HCE-080-190-S08	8	19	60	8	☑
2HCE-085-190-S10	8,5	19	70	10	☑
2HCE-090-190-S10	9	19	70	10	☑
2HCE-095-190-S10	9,5	19	70	10	☑
2HCE-100-220-S10	10	22	70	10	☑
2HCE-105-220-S12	10,5	22	75	12	☑
2HCE-110-220-S12	11	22	75	12	☑
2HCE-115-220-S12	11,5	22	75	12	☑
2HCE-120-260-S12	12	26	75	12	☑
2HCE-130-260-S14	13	26	80	14	☑
2HCE-140-260-S14	14	26	80	14	☑
2HCE-140-260-S16		26	90	16	☑
2HCE-150-350-S16	15	35	100	16	☑

Objednací číslo	D (mm)	L1 (mm)	L (mm)	d h5 (mm)	Standardní položka
2HCE-160-350-S16	16	35	100	16	☑
2HCE-170-350-S18	17	35	100	18	☑
2HCE-180-350-S18	18	35	100	18	☑
2HCE-200-400-S20	20	40	100	20	☑

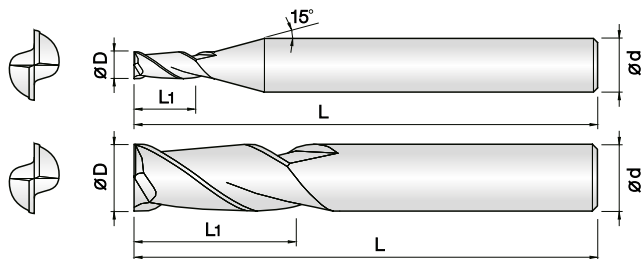

- ▶ **Určeno pro oceli a kalené oceli do HRC 58**
- ▶ Vysoká odolnost proti opotřebení díky PVD povlaku na bázi Si
- ▶ Široký sortiment délek pro optimální volbu nástroje
- ▶ Minimalizace vyštipování díky zesílení rezné hrany a tvrdokovu se zvýšenou houževnatostí

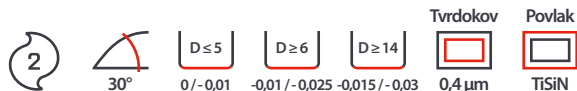

NOVINKA

Objednací číslo	D (mm)	L1 (mm)	L (mm)	d h5 (mm)	Standardní položka
2LEM-010-030-S06	1	3	60	6	☑
2LEM-010-050-S06		5	60	6	☑
2LEM-010-070-S06		7	60	6	☑
2LEM-010-100-S06		10	60	6	☑
2LEM-010-120-S06		12	60	6	☑
2LEM-010-150-S06		15	60	6	☑
2LEM-012-060-S06	1,2	6	60	6	☑
2LEM-012-080-S06		8	60	6	☑
2LEM-012-100-S06		10	60	6	☑
2LEM-012-120-S06		12	60	6	☑
2LEM-015-060-S06	1,5	6	60	6	☑
2LEM-015-075-S06		7,5	60	6	☑
2LEM-015-100-S06		10	60	6	☑
2LEM-015-150-S06		15	60	6	☑
2LEM-015-200-S06		20	60	6	☑
2LEM-020-060-S06		2	6	60	6
2LEM-020-100-S06	10		60	6	☑
2LEM-020-150-S06	15		60	6	☑
2LEM-020-200-S06	20		60	6	☑
2LEM-025-100-S06	2,5	10	60	6	☑
2LEM-025-150-S06		15	60	6	☑
2LEM-025-200-S06		20	60	6	☑
2LEM-030-120-S06	3	12	70	6	☑
2LEM-030-150-S06		15	70	6	☑
2LEM-030-200-S06		20	70	6	☑
2LEM-030-250-S06		25	70	6	☑
2LEM-030-300-S06		30	70	6	☑
2LEM-035-120-S06	3,5	12	70	6	☑
2LEM-035-150-S06		15	70	6	☑
2LEM-035-200-S06		20	70	6	☑
2LEM-040-150-S06	4	15	70	6	☑
2LEM-040-200-S06		20	70	6	☑
2LEM-040-300-S06		30	75	6	☑
2LEM-040-350-S06		35	75	6	☑
2LEM-040-400-S06		40	80	6	☑
2LEM-045-120-S06		4,5	12	70	6
2LEM-045-150-S06	15		70	6	☑
2LEM-045-200-S06	20		70	6	☑

Objednací číslo	D (mm)	L1 (mm)	L (mm)	d h5 (mm)	Standardní položka
2LEM-050-200-S06	5	20	80	6	☑
2LEM-050-250-S06		25	70	6	☑
2LEM-050-300-S06		30	75	6	☑
2LEM-050-400-S06		40	80	6	☑
2LEM-060-200-S06	6	20	75	6	☑
2LEM-060-200-100		20	100	6	☑
2LEM-060-250-S06		25	75	6	☑
2LEM-060-300-S06		30	80	6	☑
2LEM-060-350-S06		35	80	6	☑
2LEM-060-400-S06		40	90	6	☑
2LEM-060-450-S06	8	45	90	6	☑
2LEM-060-500-S06		50	100	6	☑
2LEM-080-250-S08		25	75	8	☑
2LEM-080-250-100		25	100	8	☑
2LEM-080-300-S08		30	80	8	☑
2LEM-080-350-S08		35	80	8	☑
2LEM-080-400-S08		40	90	8	☑
2LEM-080-450-S08		45	100	8	☑
2LEM-080-500-S08		50	100	8	☑
2LEM-080-550-S08		55	100	8	☑
2LEM-080-600-S08	60	110	8	☑	
2LEM-100-300-S10	10	30	80	10	☑
2LEM-100-300-110		30	110	10	☑
2LEM-100-350-S10		35	90	10	☑
2LEM-100-400-S10		40	90	10	☑
2LEM-100-450-S10		45	100	10	☑
2LEM-100-500-S10		50	100	10	☑
2LEM-100-550-S10		55	110	10	☑
2LEM-100-600-S10		60	110	10	☑
2LEM-100-650-S10		65	120	10	☑
2LEM-100-700-S10		70	120	10	☑
2LEM-120-300-S12	12	30	90	12	☑
2LEM-120-350-110		35	110	12	☑
2LEM-120-400-S12		40	100	12	☑
2LEM-120-450-S12		45	100	12	☑
2LEM-120-500-S12		50	100	12	☑
2LEM-120-550-S12		55	110	12	☑
2LEM-120-600-S12	60	110	12	☑	

2LEM 2-břité OSTRÉ frézy dlouhé pro oceli a kalené oceli do HRC 58

Objednáací číslo	D (mm)	L1 (mm)	L (mm)	d h5 (mm)	Standardní položka
2LEM-120-700-S12	12	70	130	12	<input checked="" type="checkbox"/>
2LEM-120-800-S12		80	130	12	<input checked="" type="checkbox"/>
2LEM-140-500-S14	14	50	110	14	<input checked="" type="checkbox"/>
2LEM-160-400-160	16	40	160	16	<input checked="" type="checkbox"/>
2LEM-160-550-S16		55	120	16	<input checked="" type="checkbox"/>
2LEM-160-700-S16		70	130	16	<input checked="" type="checkbox"/>
2LEM-160-800-S16		80	160	16	<input checked="" type="checkbox"/>
2LEM-160-1000-S16		100	160	16	<input checked="" type="checkbox"/>
2LEM-200-500-160	20	50	160	20	<input checked="" type="checkbox"/>
2LEM-200-600-S20		60	130	20	<input checked="" type="checkbox"/>
2LEM-200-1000-S20		100	200	20	<input checked="" type="checkbox"/>
2LEM-250-750-S25	25	75	160	25	<input checked="" type="checkbox"/>

J

SH

G

SNS

4HSE 4-břité OSTRÉ frézy krátké pro kalené oceli do HRC 60

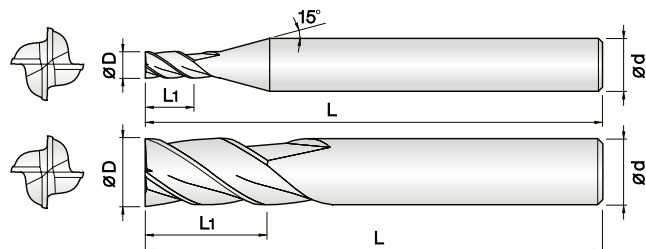

- Určeno pro kalené oceli (50–60 HRC)
- Vysoká odolnost proti opotřeбенí díky PVD povlaku na bázi Si
- Velmi přesné tolerance řezných hran
- Minimalizace vyštipování díky zesílení řezné hrany
- Vysoká tuhost
- Vynikající výkon při vysokých řezných rychlostech díky 0,2 μm tvrdokovu

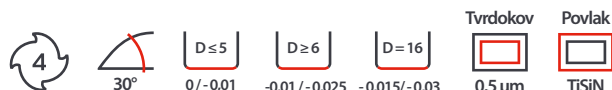

NOVINKA

Objednací číslo	D (mm)	L1 (mm)	L (mm)	d h5 (mm)	Standardní položka
4HSE-005-0075-S04	0,5	0,75	38	4	☑
4HSE-006-009-S04	0,6	0,9	38	4	☑
4HSE-008-012-S04	0,8	1,2	38	4	☑
4HSE-010-015-S04	1	1,5	40	4	☑
4HSE-012-020-S04	1,2	2	40	4	☑
4HSE-015-022-S04	1,5	2,2	40	4	☑
4HSE-020-035-S04	2	3,5	40	4	☑
4HSE-020-035-S06	2	3,5	40	6	☑
4HSE-025-038-S04	2,5	3,8	40	4	☑
4HSE-030-045-S04	3	4,5	40	4	☑
4HSE-030-045-S06	3	4,5	40	6	☑
4HSE-035-052-S06	3,5	5,2	40	6	☑
4HSE-040-060-S04	4	6	40	4	☑
4HSE-040-060-S06	4	6	40	6	☑
4HSE-045-068-S06	4,5	6,8	40	6	☑
4HSE-050-075-S06	5	7,5	45	6	☑
4HSE-060-090-S06	6	9	45	6	☑
4HSE-080-120-S08	8	12	55	8	☑
4HSE-100-150-S10	10	15	60	10	☑
4HSE-120-180-S12	12	18	65	12	☑
4HSE-160-240-S16	16	24	75	16	☑

JJ

SH

G

SUS

4HCE 4-břité OSTRÉ frézy pro kalené oceli do HRC 60

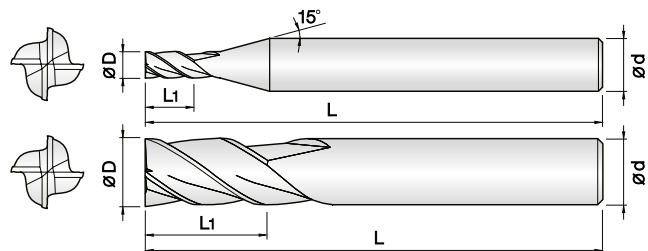

- Určeno pro kalené oceli (50–60 HRC)
- Vysoká odolnost proti opotřebování díky PVD povlaku na bázi Si
- Velmi přesné tolerance řezných hran
- Minimalizace vyštipování díky zesílení řezné hrany
- Vynikající výkon při vysokých řezných rychlostech díky 0,2 μm tvrdokovu



NOVINKA

Objednací číslo	D (mm)	L1 (mm)	L (mm)	d h5 (mm)	Standardní položka
4HCE-003-006-S04	0,3	0,6	40	4	☑
4HCE-004-008-S04	0,4	0,8	40	4	☑
4HCE-005-010-S04	0,5	1	38	4	☑
4HCE-006-012-S04	0,6	1,2	38	4	☑
4HCE-007-014-S04	0,7	1,4	38	4	☑
4HCE-008-020-S04	0,8	2	38	4	☑
4HCE-009-018-S04	0,9	1,8	38	4	☑
4HCE-010-025-S03	1	2,5	40	3	☑
4HCE-010-025-S04		2,5	40	4	☑
4HCE-010-025-S06		2,5	40	6	☑
4HCE-010-025-060		2,5	60	6	☑
4HCE-010-025-080		2,5	80	6	☑
4HCE-012-030-S03	1,2	3	40	3	☑
4HCE-012-030-S04		3	40	4	☑
4HCE-012-030-S06		3	40	6	☑
4HCE-012-030-060		3	60	6	☑
4HCE-015-040-S03	1,5	4	40	3	☑
4HCE-015-040-S04		4	40	4	☑
4HCE-015-040-S06		4	40	6	☑
4HCE-015-040-060		4	60	6	☑
4HCE-015-040-080		4	80	6	☑
4HCE-020-060-S03	2	6	40	3	☑
4HCE-020-060-S04		6	40	4	☑
4HCE-020-060-S06		6	40	6	☑
4HCE-020-060-060		6	60	6	☑
4HCE-020-060-100		6	100	6	☑
4HCE-025-080-S03	2,5	8	45	3	☑
4HCE-025-080-S04		8	45	4	☑
4HCE-025-080-S06		8	45	6	☑
4HCE-025-080-070		8	70	6	☑
4HCE-025-080-100		8	100	6	☑
4HCE-030-080-S03	3	8	45	3	☑
4HCE-030-080-S04		8	45	4	☑
4HCE-030-080-S06		8	45	6	☑
4HCE-030-080-070		8	70	6	☑
4HCE-030-080-100		8	100	6	☑
4HCE-035-100-S06	3,5	10	45	6	☑
4HCE-040-110-S04	4	11	45	4	☑

Objednací číslo	D (mm)	L1 (mm)	L (mm)	d h5 (mm)	Standardní položka
4HCE-040-110-S06	4	11	45	6	☑
4HCE-040-110-070		11	70	6	☑
4HCE-040-110-100		11	100	6	☑
4HCE-045-110-S06	4,5	11	45	6	☑
4HCE-050-130-S06	5	13	50	6	☑
4HCE-050-130-080		13	80	6	☑
4HCE-050-130-100		13	100	6	☑
4HCE-055-130-S06	5,5	13	50	6	☑
4HCE-060-130-S06	6	13	50	6	☑
4HCE-060-130-080		13	80	6	☑
4HCE-060-130-100		13	100	6	☑
4HCE-065-160-S08	6,5	16	60	8	☑
4HCE-070-160-S08	7	16	60	8	☑
4HCE-075-160-S08	7,5	16	60	8	☑
4HCE-080-190-S08	8	19	60	8	☑
4HCE-085-190-S10	8,5	19	70	10	☑
4HCE-090-190-S10	9	19	70	10	☑
4HCE-095-190-S10	9,5	19	70	10	☑
4HCE-100-220-S10	10	22	70	10	☑
4HCE-105-220-S12	10,5	22	75	12	☑
4HCE-110-220-S12	11	22	75	12	☑
4HCE-115-220-S12	11,5	22	75	12	☑
4HCE-120-260-S12	12	26	75	12	☑
4HCE-130-260-S14	13	26	80	14	☑
4HCE-140-260-S14	14	26	80	14	☑
4HCE-140-260-S16		26	90	16	☑
4HCE-150-350-S16	15	35	100	16	☑
4HCE-160-350-S16	16	35	100	16	☑
4HCE-170-350-S18	17	35	100	18	☑
4HCE-180-350-S18	18	35	100	18	☑
4HCE-200-400-S20	20	40	100	20	☑

4LEM 4-břité OSTRÉ frézy dlouhé pro oceli a kalené oceli do HRC 58

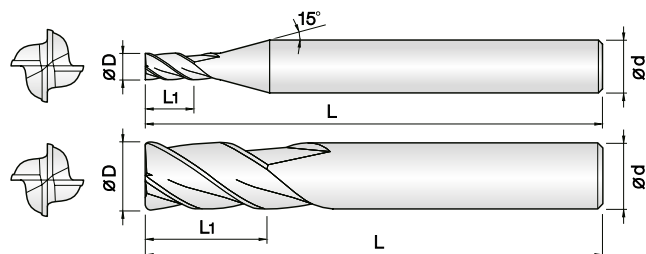

- Určeno pro oceli a kalené oceli do HRC 58
- Vysoká odolnost proti opotřebení díky PVD povlaku na bázi Si
- Široký sortiment délek pro optimální volbu nástroje
- Minimalizace vyštipování díky zesílení rezné hrany a tvrdokovu se zvýšenou houževnatostí

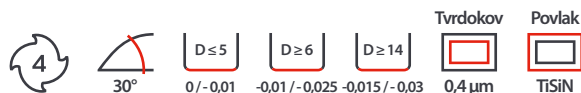

NOVINKA

Objednací číslo	D (mm)	L1 (mm)	L (mm)	d h5 (mm)	Standardní položka
4LEM-005-015-S04	0,5	1,5	40	4	☑
4LEM-005-020-S04		2	40	4	☑
4LEM-006-018-S04	0,6	1,8	40	4	☑
4LEM-006-024-S04		2,4	40	4	☑
4LEM-008-024-S04	0,8	2,4	40	4	☑
4LEM-008-032-S04		3,2	40	4	☑
4LEM-010-030-S06	1	3	60	6	☑
4LEM-010-050-S06		5	60	6	☑
4LEM-010-070-S06		7	60	6	☑
4LEM-010-100-S06		10	60	6	☑
4LEM-010-120-S06	1,2	12	60	6	☑
4LEM-012-040-S06		4	60	6	☑
4LEM-012-060-S06		6	60	6	☑
4LEM-012-080-S06		8	60	6	☑
4LEM-012-100-S06	1,5	10	60	6	☑
4LEM-015-060-S06		6	60	6	☑
4LEM-015-080-S06		8	60	6	☑
4LEM-015-100-S06		10	60	6	☑
4LEM-015-120-S06	2	12	60	6	☑
4LEM-015-150-S06		15	60	6	☑
4LEM-020-080-S06		8	60	6	☑
4LEM-020-100-S06		10	60	6	☑
4LEM-020-120-S06	3	12	60	6	☑
4LEM-020-150-S06		15	60	6	☑
4LEM-020-200-S06		20	70	6	☑
4LEM-030-100-S06		10	70	6	☑
4LEM-030-150-S06	3,5	15	70	6	☑
4LEM-030-200-S06		20	70	6	☑
4LEM-030-250-S06		25	70	6	☑
4LEM-030-300-S06		30	70	6	☑
4LEM-030-350-S06	4	35	75	6	☑
4LEM-030-400-S06		40	80	6	☑
4LEM-035-120-S06		12	70	6	☑
4LEM-035-150-S06		15	70	6	☑
4LEM-035-200-S06	4	20	70	6	☑
4LEM-040-120-S06		12	70	6	☑
4LEM-040-150-S04		15	70	4	☑
4LEM-040-150-S06		15	70	6	☑

Objednací číslo	D (mm)	L1 (mm)	L (mm)	d h5 (mm)	Standardní položka
4LEM-040-200-S04	4	20	70	4	☑
4LEM-040-200-S06		20	70	6	☑
4LEM-040-250-S06		25	70	6	☑
4LEM-040-300-S06		30	75	6	☑
4LEM-040-350-S06		35	75	6	☑
4LEM-040-400-S06		40	80	6	☑
4LEM-040-450-S06		45	90	6	☑
4LEM-040-500-S06		50	100	6	☑
4LEM-045-150-S06	4,5	15	70	6	☑
4LEM-045-200-S06		20	70	6	☑
4LEM-050-200-S06	5	20	70	6	☑
4LEM-050-250-S06		25	75	6	☑
4LEM-050-300-S06		30	80	6	☑
4LEM-050-400-S06		40	80	6	☑
4LEM-050-500-S06	6	50	100	6	☑
4LEM-060-200-S06		20	75	6	☑
4LEM-060-200-100		20	100	6	☑
4LEM-060-250-S06		25	75	6	☑
4LEM-060-300-S06	6	30	80	6	☑
4LEM-060-350-S06		35	80	6	☑
4LEM-060-400-S06		40	90	6	☑
4LEM-060-450-S06		45	90	6	☑
4LEM-060-500-S06	8	50	100	6	☑
4LEM-080-250-S08		25	75	8	☑
4LEM-080-250-100		25	100	8	☑
4LEM-080-300-S08		30	80	8	☑
4LEM-080-350-S08	8	35	90	8	☑
4LEM-080-400-S08		40	90	8	☑
4LEM-080-450-S08		45	100	8	☑
4LEM-080-500-S08		50	100	8	☑
4LEM-080-550-S08	10	55	100	8	☑
4LEM-080-600-S08		60	110	8	☑
4LEM-100-300-S10		30	80	10	☑
4LEM-100-300-110		30	110	10	☑
4LEM-100-350-S10	10	35	90	10	☑
4LEM-100-400-S10		40	90	10	☑
4LEM-100-450-S10		45	100	10	☑
4LEM-100-500-S10		50	100	10	☑

Objednací číslo	D (mm)	L1 (mm)	L (mm)	d h5 (mm)	Standardní položka
4LEM-100-550-S10	10	55	100	10	<input checked="" type="checkbox"/>
4LEM-100-600-S10		60	110	10	<input checked="" type="checkbox"/>
4LEM-100-650-S10		65	120	10	<input checked="" type="checkbox"/>
4LEM-100-700-S10		70	120	10	<input checked="" type="checkbox"/>
4LEM-120-300-S12	12	30	90	12	<input checked="" type="checkbox"/>
4LEM-120-350-110		35	110	12	<input checked="" type="checkbox"/>
4LEM-120-400-S12		40	100	12	<input checked="" type="checkbox"/>
4LEM-120-450-S12		45	100	12	<input checked="" type="checkbox"/>
4LEM-120-500-S12		50	100	12	<input checked="" type="checkbox"/>
4LEM-120-550-S12		55	110	12	<input checked="" type="checkbox"/>
4LEM-120-600-S12		60	110	12	<input checked="" type="checkbox"/>
4LEM-120-700-S12		70	130	12	<input checked="" type="checkbox"/>
4LEM-120-800-S12	14	80	130	12	<input checked="" type="checkbox"/>
4LEM-140-500-S14		50	110	14	<input checked="" type="checkbox"/>
4LEM-160-400-160	16	40	160	16	<input checked="" type="checkbox"/>
4LEM-160-550-S16		55	120	16	<input checked="" type="checkbox"/>
4LEM-160-700-S16		70	130	16	<input checked="" type="checkbox"/>
4LEM-160-900-S16		90	150	16	<input checked="" type="checkbox"/>
4LEM-160-1000-S16		100	160	16	<input checked="" type="checkbox"/>
4LEM-200-500-160	20	50	160	20	<input checked="" type="checkbox"/>
4LEM-200-600-S20		60	130	20	<input checked="" type="checkbox"/>
4LEM-200-800-S20		80	160	20	<input checked="" type="checkbox"/>
4LEM-200-1000-S20		100	200	20	<input checked="" type="checkbox"/>
4LEM-250-750-S25	25	75	160	25	<input checked="" type="checkbox"/>

4HEM 4-břité OSTRÉ frézy 45° pro kalené oceli do HRC 60

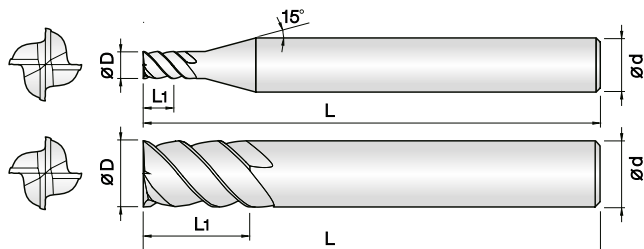

- Určeno pro kalené oceli (50–60 HRC)
- Vysoká odolnost proti opotřeбенí díky PVD povlaku na bázi Si
- Velmi přesné tolerance řezných hran
- Minimalizace vyštipování díky zesílení řezné hrany
- Vyšší posuvy díky 45° geometrii
- Vynikající výkon při vysokých řezných rychlostech díky 0,2 μm tvrdokovu



Objednací číslo	D (mm)	L1 (mm)	L (mm)	d h5 (mm)	Standardní položka
4HEM-010-025-S06	1	2,5	40	6	☑
4HEM-010-035-S06		3,5	40	6	☑
4HEM-010-050-S06		5	45	6	☑
4HEM-012-030-S06		1,2	3	40	6
4HEM-015-040-S06	1,5	4	40	6	☑
4HEM-015-060-S06		6	40	6	☑
4HEM-015-080-S06		8	45	6	☑
4HEM-020-050-S06	2	5	40	6	☑
4HEM-020-080-S06		8	45	6	☑
4HEM-020-100-S06		10	50	6	☑
4HEM-030-080-S06	3	8	45	6	☑
4HEM-030-120-S06		12	50	6	☑
4HEM-030-150-S06		15	55	6	☑
4HEM-040-110-S06	4	11	45	6	☑
4HEM-040-160-S06		16	55	6	☑
4HEM-040-200-S06		20	60	6	☑
4HEM-050-130-S06	5	13	50	6	☑
4HEM-050-180-S06		18	60	6	☑
4HEM-050-250-S06		25	70	6	☑
4HEM-060-130-S06	6	13	50	6	☑
4HEM-060-200-S06		20	60	6	☑
4HEM-060-250-S06		25	70	6	☑
4HEM-080-200-S08	8	20	60	8	☑
4HEM-080-250-S08		25	70	8	☑
4HEM-080-300-S08		30	75	8	☑
4HEM-080-400-S08	10	40	90	8	☑
4HEM-100-220-S10		22	70	10	☑
4HEM-100-300-S10		30	80	10	☑
4HEM-100-400-S10	12	40	90	10	☑
4HEM-100-500-S10		50	100	10	☑
4HEM-120-260-S12		26	75	12	☑
4HEM-120-400-S12	14	40	90	12	☑
4HEM-120-500-S12		50	100	12	☑
4HEM-120-600-S12		60	110	12	☑
4HEM-140-300-S14	16	30	80	14	☑
4HEM-140-500-S14		50	110	14	☑
4HEM-160-350-S16	16	35	90	16	☑
4HEM-160-500-S16		50	110	16	☑

Objednací číslo	D (mm)	L1 (mm)	L (mm)	d h5 (mm)	Standardní položka
4HEM-160-650-S16	16	65	120	16	☑
4HEM-200-400-S20	20	40	100	20	☑
4HEM-200-500-S20		50	110	20	☑
4HEM-200-700-S20		70	130	20	☑
4HEM-250-800-S25	25	80	160	25	☑

6&8HEM

6 a 8-břité OSTRÉ frézy 45° pro kalené oceli do HRC 62

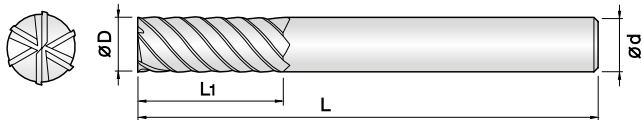

- ▶ **Určeno pro kalené oceli (50–62 HRC)**
- ▶ Vysoká odolnost proti opotřeбенí díky PVD povlaku na bázi Si
- ▶ Velmi přesné tolerance řezných hran
- ▶ Minimalizace vyštipování díky zesílení řezné hrany
- ▶ Vyšší posuvy díky 45° geometrii
- ▶ Vynikající výkon při vysokých řezných rychlostech díky 0,2 μm tvrdkovu

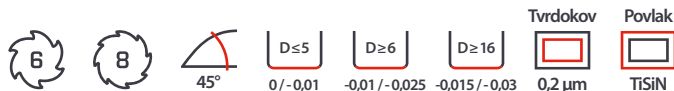

Objednací číslo	D (mm)	L1 (mm)	L (mm)	d h5 (mm)	Standardní položka
6HEM-030-100-S06	3	10	50	6	☑
6HEM-030-150-S06		15	50	6	☑
6HEM-040-120-S06	4	12	50	6	☑
6HEM-040-160-S06		16	50	6	☑
6HEM-050-150-S06	5	15	50	6	☑
6HEM-050-200-S06		20	60	6	☑
6HEM-060-150-S06	6	15	50	6	☑
6HEM-060-200-S06		20	60	6	☑
6HEM-060-250-S06		25	65	6	☑
6HEM-060-300-S06		30	70	6	☑
6HEM-060-350-S06	8	35	75	6	☑
6HEM-080-200-S08		20	60	8	☑
6HEM-080-250-S08		25	65	8	☑
6HEM-080-300-S08		30	75	8	☑
6HEM-080-350-S08		35	80	8	☑
6HEM-080-400-S08		40	90	8	☑
6HEM-080-450-S08	10	45	100	8	☑
6HEM-080-500-S08		50	100	8	☑
6HEM-100-250-S10	10	25	70	10	☑
6HEM-100-350-S10		35	90	10	☑
6HEM-100-450-S10		45	100	10	☑
6HEM-100-500-S10		50	100	10	☑
6HEM-100-600-S10	12	60	110	10	☑
6HEM-120-300-S12		30	80	12	☑
6HEM-120-400-S12		40	90	12	☑
6HEM-120-500-S12		50	100	12	☑
6HEM-120-600-S12		60	110	12	☑
6HEM-120-700-S12		70	120	12	☑
6HEM-160-350-S16	16	35	90	16	☑
6HEM-160-500-S16		50	110	16	☑
6HEM-160-650-S16		65	120	16	☑
6HEM-160-800-S16		80	150	16	☑
6HEM-160-900-S16		90	160	16	☑
6HEM-160-1000-S16	20	100	160	16	☑
6HEM-200-450-S20		45	100	20	☑
6HEM-200-600-S20		60	120	20	☑
6HEM-200-800-S20		80	150	20	☑
6HEM-200-900-S20		90	160	20	☑

Objednací číslo	D (mm)	L1 (mm)	L (mm)	d h5 (mm)	Standardní položka
6HEM-200-1000-S20	20	100	160	20	☑
6HEM-200-1100-S20		110	170	20	☑
6HEM-200-1200-S20		120	180	20	☑
8HEM-250-1000-S25	25	100	160	25	☑
8HEM-250-1250-S25		125	200	25	☑

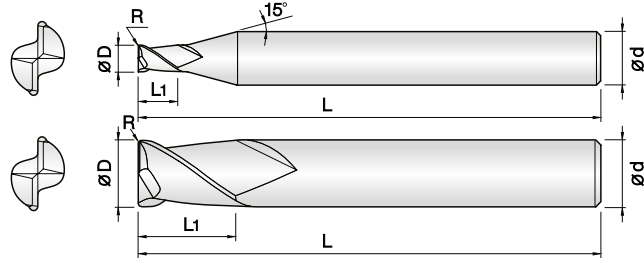

- Určeno pro kalené oceli (50–62 HRC)
- Vysoká odolnost proti opotřeby díky PVD povlaku na bázi Si
- Velmi přesné tolerance řezných hran
- Široký sortiment rádiusů a délek pro optimální výběr nástroje
- Vynikající výkon při vysokých řezných rychlostech díky 0,2 μm tvrdokovu

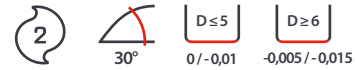

NOVINKA

Objednací číslo	D (mm)	R (mm)	L1 (mm)	L (mm)	d h5 (mm)	Standardní položka
2NCR-002-0002-S04	0,2	R 0,02	0,6	45	4	☑
2NCR-002-0005-S04		R 0,05	0,6	45	4	☑
2NCR-003-0002-S04	0,3	R 0,02	0,6	45	4	☑
2NCR-003-0005-S04		R 0,05	0,6	45	4	☑
2NCR-003-001-S04		R 0,1	0,6	45	4	☑
2NCR-004-0002-S04	0,4	R 0,02	0,8	45	4	☑
2NCR-004-0005-S04		R 0,05	0,8	45	4	☑
2NCR-004-001-S04		R 0,1	0,8	45	4	☑
2NCR-005-0002-S04	0,5	R 0,02	1	45	4	☑
2NCR-005-0005-S04		R 0,05	1	45	4	☑
2NCR-005-001-S04		R 0,1	1	45	4	☑
2NCR-006-0002-S04	0,6	R 0,02	1,2	45	4	☑
2NCR-006-0005-S04		R 0,05	1,2	45	4	☑
2NCR-006-001-S04		R 0,1	1,2	45	4	☑
2NCR-006-002-S04		R 0,2	1,2	45	4	☑
2NCR-007-0005-S04	0,7	R 0,05	1,4	45	4	☑
2NCR-007-001-S04		R 0,1	1,4	45	4	☑
2NCR-007-002-S04		R 0,2	1,4	45	4	☑
2NCR-008-0002-S04	0,8	R 0,02	1,6	45	4	☑
2NCR-008-0005-S04		R 0,05	1,6	45	4	☑
2NCR-008-001-S04		R 0,1	1,6	45	4	☑
2NCR-008-002-S04		R 0,2	1,6	45	4	☑
2NCR-009-0005-S04	0,9	R 0,05	1,8	45	4	☑
2NCR-009-001-S04		R 0,1	1,8	45	4	☑
2NCR-010-0002-S04	1	R 0,02	2,5	45	4	☑
2NCR-010-0005-S04		R 0,05	2,5	45	4	☑
2NCR-010-001-S04		R 0,1	2,5	45	4	☑
2NCR-010-002-S04		R 0,2	2,5	45	4	☑
2NCR-010-003-S04		R 0,3	2,5	45	4	☑
2NCR-010-004-S04		R 0,4	2,5	45	4	☑
2NCR-012-0005-S04	1,2	R 0,05	3,2	45	4	☑
2NCR-012-001-S04		R 0,1	3,2	45	4	☑
2NCR-012-002-S04		R 0,2	3,2	45	4	☑
2NCR-012-003-S04		R 0,3	3,2	45	4	☑
2NCR-015-0002-S04	1,5	R 0,02	4	45	4	☑
2NCR-015-0005-S04		R 0,05	4	45	4	☑
2NCR-015-001-S04		R 0,1	4	45	4	☑
2NCR-015-002-S04		R 0,2	4	45	4	☑

Objednací číslo	D (mm)	R (mm)	L1 (mm)	L (mm)	d h5 (mm)	Standardní položka
2NCR-015-003-S04	1,5	R 0,3	4	45	4	☑
2NCR-015-004-S04		R 0,4	4	45	4	☑
2NCR-015-005-S04		R 0,5	4	45	4	☑
2NCR-020-0002-S04	2	R 0,02	6	45	4	☑
2NCR-020-0005-S04		R 0,05	6	45	4	☑
2NCR-020-001-S04		R 0,1	6	45	4	☑
2NCR-020-002-S04		R 0,2	6	45	4	☑
2NCR-020-003-S04		R 0,3	6	45	4	☑
2NCR-020-004-S04		R 0,4	6	45	4	☑
2NCR-020-005-S04		R 0,5	6	45	4	☑
2NCR-025-0005-S04	2,5	R 0,05	6	50	4	☑
2NCR-025-001-S04		R 0,1	6	50	4	☑
2NCR-025-002-S04		R 0,2	6	50	4	☑
2NCR-025-003-S04		R 0,3	6	50	4	☑
2NCR-025-004-S04		R 0,4	6	50	4	☑
2NCR-025-005-S04		R 0,5	6	50	4	☑
2NCR-030-0005-S06	3	R 0,05	8	60	6	☑
2NCR-030-001-S06		R 0,1	8	60	6	☑
2NCR-030-002-S06		R 0,2	8	60	6	☑
2NCR-030-003-S06		R 0,3	8	60	6	☑
2NCR-030-004-S06		R 0,4	8	60	6	☑
2NCR-030-005-S06		R 0,5	8	60	6	☑
2NCR-030-010-S06		R 1	8	60	6	☑
2NCR-035-001-S06	3,5	R 0,1	9	70	6	☑
2NCR-035-002-S06		R 0,2	9	70	6	☑
2NCR-035-003-S06		R 0,3	9	70	6	☑
2NCR-035-005-S06		R 0,5	9	70	6	☑
2NCR-035-010-S06		R 1	9	70	6	☑
2NCR-040-0005-060	4	R 0,05	9	60	4	☑
2NCR-040-0005-080			9	80	4	☑
2NCR-040-0005-S06			9	70	6	☑
2NCR-040-001-060		R 0,1	9	60	4	☑
2NCR-040-001-080			9	80	4	☑
2NCR-040-001-S06			10	70	6	☑
2NCR-040-002-060		R 0,2	9	60	4	☑
2NCR-040-002-080			9	80	4	☑
2NCR-040-002-S06			10	70	6	☑
2NCR-040-003-060		R 0,3	9	60	4	☑

NOVINKA

Objednací číslo	D (mm)	R (mm)	L1 (mm)	L (mm)	d h5 (mm)	Standardní položka
2NCR-040-003-080	4	R 0,3	9	80	4	☑
2NCR-040-003-506		R 0,3	10	70	6	☑
2NCR-040-004-060		R 0,4	9	60	4	☑
2NCR-040-004-080			9	80	4	☑
2NCR-040-004-506		R 0,5	10	70	6	☑
2NCR-040-005-060			9	60	4	☑
2NCR-040-005-080			9	80	4	☑
2NCR-040-005-506		R 1	10	70	6	☑
2NCR-040-010-060			9	60	4	☑
2NCR-040-010-080			9	80	4	☑
2NCR-040-010-506			10	70	6	☑
2NCR-045-001-506		4,5	R 0,1	11	75	6
2NCR-045-002-506	R 0,2		11	75	6	☑
2NCR-045-003-506	R 0,3		11	75	6	☑
2NCR-045-005-506	R 0,5		11	75	6	☑
2NCR-045-010-506	R 1		11	75	6	☑
2NCR-050-001-506	5	R 0,1	13	75	6	☑
2NCR-050-002-506		R 0,2	13	75	6	☑
2NCR-050-003-506		R 0,3	13	75	6	☑
2NCR-050-004-506		R 0,4	13	75	6	☑
2NCR-050-005-506		R 0,5	13	75	6	☑
2NCR-050-010-506		R 1	13	75	6	☑
2NCR-055-002-506	5,5	R 0,2	13	75	6	☑
2NCR-055-003-506		R 0,3	13	75	6	☑
2NCR-055-005-506		R 0,5	13	75	6	☑
2NCR-055-010-506		R 1	13	75	6	☑
2NCR-060-0005-060	6	R 0,05	11	60	6	☑
2NCR-060-0005-090			13	90	6	☑
2NCR-060-001-060		R 0,1	11	60	6	☑
2NCR-060-001-090			13	90	6	☑
2NCR-060-002-060		R 0,2	11	60	6	☑
2NCR-060-002-090			13	90	6	☑
2NCR-060-003-060		R 0,3	11	60	6	☑
2NCR-060-003-090			13	90	6	☑
2NCR-060-004-060		R 0,4	11	60	6	☑
2NCR-060-004-090			13	90	6	☑
2NCR-060-005-060		R 0,5	11	60	6	☑
2NCR-060-005-090			13	90	6	☑
2NCR-060-010-060		R 1	11	60	6	☑
2NCR-060-010-090			13	90	6	☑
2NCR-060-015-060			11	60	6	☑
2NCR-060-015-090		R 1,5	13	90	6	☑
2NCR-060-020-060			R 2	11	60	6
2NCR-060-020-090		R 2	13	90	6	☑
2NCR-060-025-090	R 2,5	13	90	6	☑	
2NCR-080-001-070	8	R 0,1	16	70	8	☑
2NCR-080-001-100			19	100	8	☑
2NCR-080-002-070		R 0,2	16	70	8	☑
2NCR-080-002-100			19	100	8	☑
2NCR-080-003-070		R 0,3	16	70	8	☑
2NCR-080-003-100			19	100	8	☑
2NCR-080-005-070		R 0,5	16	70	8	☑

Objednací číslo	D (mm)	R (mm)	L1 (mm)	L (mm)	d h5 (mm)	Standardní položka
2NCR-080-005-100	8	R 0,5	19	100	8	☑
2NCR-080-005-120			19	120	8	☑
2NCR-080-010-070		R 1	16	70	8	☑
2NCR-080-010-100			19	100	8	☑
2NCR-080-010-120			19	120	8	☑
2NCR-080-015-070		R 1,5	16	70	8	☑
2NCR-080-015-100			19	100	8	☑
2NCR-080-020-070		R 2	16	70	8	☑
2NCR-080-020-100			19	100	8	☑
2NCR-080-025-100		R 2,5	19	100	8	☑
2NCR-080-030-100		R 3	19	100	8	☑
2NCR-080-035-100		R 3,5	19	100	8	☑
2NCR-100-001-075	10	R 0,1	19	75	10	☑
2NCR-100-001-100			22	100	10	☑
2NCR-100-002-075		R 0,2	19	75	10	☑
2NCR-100-002-100			22	100	10	☑
2NCR-100-003-075		R 0,3	19	75	10	☑
2NCR-100-003-100			22	100	10	☑
2NCR-100-005-075		R 0,5	19	75	10	☑
2NCR-100-005-100			22	100	10	☑
2NCR-100-005-130			22	130	10	☑
2NCR-100-010-075		R 1	19	75	10	☑
2NCR-100-010-100			22	100	10	☑
2NCR-100-010-130			22	130	10	☑
2NCR-100-015-075			19	75	10	☑
2NCR-100-015-100		R 1,5	22	100	10	☑
2NCR-100-015-130			22	130	10	☑
2NCR-100-020-075		R 2	19	75	10	☑
2NCR-100-020-100			22	100	10	☑
2NCR-100-025-100		R 2,5	22	100	10	☑
2NCR-100-030-100	R 3	22	100	10	☑	
2NCR-100-040-100	R 4	22	100	10	☑	
2NCR-120-001-080	12	R 0,1	22	80	12	☑
2NCR-120-001-110			26	110	12	☑
2NCR-120-002-080		R 0,2	22	80	12	☑
2NCR-120-002-110			26	110	12	☑
2NCR-120-003-080		R 0,3	22	80	12	☑
2NCR-120-003-110			26	110	12	☑
2NCR-120-005-080		R 0,5	22	80	12	☑
2NCR-120-005-110			26	110	12	☑
2NCR-120-005-130			26	130	12	☑
2NCR-120-010-080		R 1	22	80	12	☑
2NCR-120-010-110			26	110	12	☑
2NCR-120-010-130		R 1	26	130	12	☑
2NCR-120-015-080		R 1,5	22	80	12	☑
2NCR-120-015-110			26	110	12	☑
2NCR-120-015-130			26	130	12	☑
2NCR-120-020-080		R 2	22	80	12	☑
2NCR-120-020-110			26	110	12	☑
2NCR-120-020-130		R 2,5	26	130	12	☑
2NCR-120-025-110	R 3	26	110	12	☑	
2NCR-120-030-110	R 3	26	110	12	☑	

NOVINKA

Objednací číslo	D (mm)	R (mm)	L1 (mm)	L (mm)	d h5 (mm)	Standardní položka
2NCR-120-040-110	12	R 4	26	110	12	<input checked="" type="checkbox"/>
2NCR-120-050-110		R 5	26	110	12	<input checked="" type="checkbox"/>
2NCR-140-005-110	14	R 0,5	30	110	14	<input checked="" type="checkbox"/>
2NCR-140-010-110		R 1	30	110	14	<input checked="" type="checkbox"/>
2NCR-140-020-110		R 2	30	110	14	<input checked="" type="checkbox"/>
2NCR-160-005-160	16	R 0,5	32	160	16	<input checked="" type="checkbox"/>
2NCR-160-010-160		R 1	32	160	16	<input checked="" type="checkbox"/>

4NCR 4-břité TOROIDNÍ frézy pro kalené oceli do HRC 62

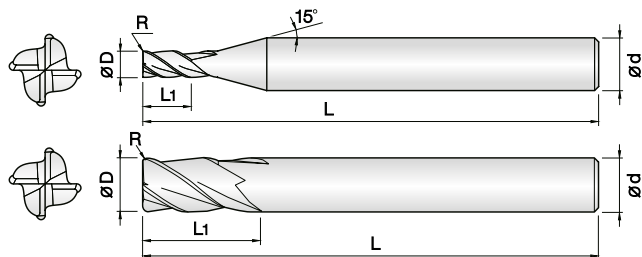

- Určeno pro kalené oceli (50–62 HRC)
- Vysoká odolnost proti opotřebování díky PVD povlaku na bázi Si
- Velmi přesné tolerance řezných hran
- Široký sortiment rádiusů a délek pro optimální výběr nástroje
- Vynikající výkon při vysokých řezných rychlostech díky 0,2 μm tvrdokovu



NOVINKA

Objednací-číslo	D (mm)	R (mm)	L1 (mm)	L (mm)	d-h5 (mm)	Standardní položka
4NCR-005-0005-S04	0,5	R 0,05	1	45	4	☑
4NCR-005-001-S04		R 0,1	1	45	4	☑
4NCR-006-001-S04	0,6	R 0,1	1,2	45	4	☑
4NCR-006-002-S04		R 0,02	1,2	45	4	☑
4NCR-008-001-S04	0,8	R 0,1	1,6	45	4	☑
4NCR-008-002-S04		R 0,02	1,6	45	4	☑
4NCR-010-0002-S04	1	R 0,02	2,5	45	4	☑
4NCR-010-0005-S04		R 0,05	2,5	45	4	☑
4NCR-010-001-S04		R 0,1	2,5	45	4	☑
4NCR-010-002-S04		R 0,2	2,5	45	4	☑
4NCR-010-003-S04	1,2	R 0,3	2,5	45	4	☑
4NCR-012-0002-S04		R 0,02	4	45	4	☑
4NCR-012-0005-S04		R 0,05	4	45	4	☑
4NCR-012-001-S04		R 0,1	4	45	4	☑
4NCR-012-002-S04		R 0,2	4	45	4	☑
4NCR-012-003-S04		R 0,3	4	45	4	☑
4NCR-015-0002-S04	1,5	R 0,02	4	45	4	☑
4NCR-015-0005-S04		R 0,05	4	45	4	☑
4NCR-015-001-S04		R 0,1	4	45	4	☑
4NCR-015-002-S04		R 0,2	4	45	4	☑
4NCR-015-003-S04		R 0,3	4	45	4	☑
4NCR-015-004-S04		R 0,4	4	45	4	☑
4NCR-015-005-S04	2	R 0,5	4	45	4	☑
4NCR-020-0002-S04		R 0,02	6	45	4	☑
4NCR-020-0005-S04		R 0,05	6	45	4	☑
4NCR-020-001-S04		R 0,1	6	45	4	☑
4NCR-020-002-S04		R 0,2	6	45	4	☑
4NCR-020-003-S04		R 0,3	6	45	4	☑
4NCR-020-004-S04	2,5	R 0,4	6	45	4	☑
4NCR-020-005-S04		R 0,5	6	45	4	☑
4NCR-025-0005-S04		R 0,05	6	50	4	☑
4NCR-025-001-S04		R 0,1	6	50	4	☑
4NCR-025-002-S04		R 0,2	6	50	4	☑
4NCR-025-003-S04		R 0,3	6	50	4	☑
4NCR-025-005-S04	3	R 0,5	6	50	4	☑
4NCR-030-0005-S06		R 0,05	8	60	6	☑
4NCR-030-001-S06		R 0,1	8	60	6	☑
4NCR-030-002-S06	R 0,2	8	60	6	☑	

Objednací-číslo	D (mm)	R (mm)	L1 (mm)	L (mm)	d-h5 (mm)	Standardní položka
4NCR-030-003-S06	3	R 0,3	8	60	6	☑
4NCR-030-004-S06		R 0,4	8	60	6	☑
4NCR-030-005-S06		R 0,5	8	60	6	☑
4NCR-030-010-S06		R 1	8	60	6	☑
4NCR-040-0005-060	4	R 0,05	9	60	4	☑
4NCR-040-0005-080			9	80	4	☑
4NCR-040-0005-S06		R 0,05	10	70	6	☑
4NCR-040-001-060		R 0,1	9	60	4	☑
4NCR-040-001-080			9	80	4	☑
4NCR-040-001-S06			10	70	6	☑
4NCR-040-002-060		R 0,2	9	60	4	☑
4NCR-040-002-080			9	80	4	☑
4NCR-040-002-S06		10	70	6	☑	
4NCR-040-003-060		R 0,3	9	60	4	☑
4NCR-040-003-080			9	80	4	☑
4NCR-040-003-S06			10	70	6	☑
4NCR-040-004-060	R 0,4	9	60	4	☑	
4NCR-040-004-080		9	80	4	☑	
4NCR-040-004-S06		10	70	6	☑	
4NCR-040-005-060	R 0,5	9	60	4	☑	
4NCR-040-005-080		9	80	4	☑	
4NCR-040-005-S06		10	70	6	☑	
4NCR-040-010-060		R 1	9	60	4	☑
4NCR-040-010-080	9		80	4	☑	
4NCR-040-010-S06	10	70	6	☑		
4NCR-050-0005-S06	5	R 0,05	13	75	6	☑
4NCR-050-001-S06		R 0,1	13	75	6	☑
4NCR-050-002-S06		R 0,2	13	75	6	☑
4NCR-050-003-S06		R 0,3	13	75	6	☑
4NCR-050-004-S06		R 0,4	13	75	6	☑
4NCR-050-005-S06		R 0,5	13	75	6	☑
4NCR-050-010-S06	5,5	R 1	13	75	6	☑
4NCR-055-002-S06		R 0,2	13	75	6	☑
4NCR-055-003-S06		R 0,3	13	75	6	☑
4NCR-055-005-S06		R 0,5	13	75	6	☑
4NCR-055-010-S06	6	R 1	13	75	6	☑
4NCR-060-0005-080		R 0,05	13	80	6	☑
4NCR-060-001-060	R 0,1	11	60	6	☑	

NOVINKA

Objednací-číslo	D (mm)	R (mm)	L1 (mm)	L (mm)	d-h5 (mm)	Standardní položka	
4NCR-060-001-080	6	R 0,1	13	80	6	☑	
4NCR-060-002-060		R 0,2	11	60	6	☑	
4NCR-060-002-080			13	80	6	☑	
4NCR-060-003-060		R 0,3	11	60	6	☑	
4NCR-060-003-080			13	80	6	☑	
4NCR-060-004-080		R 0,4	13	80	6	☑	
4NCR-060-005-060		R 0,5	11	60	6	☑	
4NCR-060-005-080			13	80	6	☑	
4NCR-060-010-060		R 1	11	60	6	☑	
4NCR-060-010-080			13	80	6	☑	
4NCR-060-015-060		R 1,5	11	60	6	☑	
4NCR-060-015-080			13	80	6	☑	
4NCR-060-020-060		R 2	11	60	6	☑	
4NCR-060-020-080			13	80	6	☑	
4NCR-080-001-070		8	R 0,1	16	70	8	☑
4NCR-080-001-090				19	90	8	☑
4NCR-080-002-070	R 0,2		16	70	8	☑	
4NCR-080-002-090			19	90	8	☑	
4NCR-080-003-070	R 0,3		16	70	8	☑	
4NCR-080-003-090			19	90	8	☑	
4NCR-080-005-070	R 0,5		16	70	8	☑	
4NCR-080-005-090			19	90	8	☑	
4NCR-080-005-110	R 1		19	110	8	☑	
4NCR-080-010-070			16	70	8	☑	
4NCR-080-010-090	R 1,5		19	90	8	☑	
4NCR-080-010-110			19	110	8	☑	
4NCR-080-015-070	R 1,5		16	70	8	☑	
4NCR-080-015-090			19	90	8	☑	
4NCR-080-015-110	R 2		19	110	8	☑	
4NCR-080-020-070			16	70	8	☑	
4NCR-080-020-090	R 2	19	90	8	☑		
4NCR-080-020-110		19	110	8	☑		
4NCR-080-025-090	R 2,5	19	90	8	☑		
4NCR-100-001-075	10	R 0,1	19	75	10	☑	
4NCR-100-001-100			22	100	10	☑	
4NCR-100-002-075		R 0,2	19	75	10	☑	
4NCR-100-002-100			22	100	10	☑	
4NCR-100-002-120		R 0,3	22	120	10	☑	
4NCR-100-003-075			19	75	10	☑	
4NCR-100-003-100		R 0,3	22	100	10	☑	
4NCR-100-005-075			19	75	10	☑	
4NCR-100-005-100		R 0,5	22	100	10	☑	
4NCR-100-005-120			22	120	10	☑	
4NCR-100-010-075		R 1	19	75	10	☑	
4NCR-100-010-100			22	100	10	☑	
4NCR-100-010-120		R 1	22	120	10	☑	
4NCR-100-015-075			R 1,5	19	75	10	☑
4NCR-100-015-100		22		100	10	☑	
4NCR-100-015-120		R 1,5	22	120	10	☑	
4NCR-100-020-075	R 2		19	75	10	☑	
4NCR-100-020-100		22	100	10	☑		
4NCR-100-020-120	R 2	22	120	10	☑		

Objednací-číslo	D (mm)	R (mm)	L1 (mm)	L (mm)	d-h5 (mm)	Standardní položka
4NCR-100-025-075	10	R 2,5	19	75	10	☑
4NCR-100-025-100			22	100	10	☑
4NCR-100-025-120			22	120	10	☑
4NCR-100-030-100	R 3	22	100	10	☑	
4NCR-120-002-080		12	R 0,2	22	80	12
4NCR-120-002-110	26			110	12	☑
4NCR-120-002-130	R 0,3		22	120	10	☑
4NCR-120-003-080			22	80	12	☑
4NCR-120-003-110	R 0,3	26	110	12	☑	
4NCR-120-005-080		R 0,5	22	80	12	☑
4NCR-120-005-110	R 0,5		26	110	12	☑
4NCR-120-005-130		R 0,5	26	130	12	☑
4NCR-120-010-080	R 1		22	80	12	☑
4NCR-120-010-110		26	110	12	☑	
4NCR-120-010-130		26	130	12	☑	
4NCR-120-015-080	R 1,5	22	80	12	☑	
4NCR-120-015-110		R 1,5	26	110	12	☑
4NCR-120-015-130	R 1,5		26	130	12	☑
4NCR-120-020-080		R 2	22	80	12	☑
4NCR-120-020-110	R 2		26	110	12	☑
4NCR-120-020-130			26	130	12	☑
4NCR-120-025-080	R 2,5	22	80	12	☑	
4NCR-120-025-110		R 2,5	26	110	12	☑
4NCR-120-025-130	R 2,5		26	130	12	☑
4NCR-120-030-080		R 3	22	80	12	☑
4NCR-120-030-110	R 3		26	110	12	☑
4NCR-120-030-130			26	130	12	☑
4NCR-120-035-110	R 3,5	26	110	12	☑	
4NCR-120-040-110	R 4	26	110	12	☑	
4NCR-140-005-110	14	R 0,5	30	110	14	☑
4NCR-140-010-110		R 1	30	110	14	☑
4NCR-140-020-110			R 2	30	110	14
4NCR-160-005-110	16	R 0,5	32	110	16	☑
4NCR-160-005-160			32	160	16	☑
4NCR-160-010-110		R 1	32	110	16	☑
4NCR-160-010-160			32	160	16	☑
4NCR-160-015-110			32	160	16	☑
4NCR-160-020-110	R 2	32	110	16	☑	
4NCR-160-030-110	R 3	32	110	16	☑	
4NCR-200-005-160	20	R 0,5	38	160	20	☑
4NCR-200-010-160		R 1	38	160	20	☑
4NCR-200-015-160			R 1,5	38	160	20
4NCR-200-020-160		R 2	38	160	20	☑

11

SH

G

SNS

4CRL 4-břité TOROIDNÍ frézy 45° pro kalené oceli do HRC 62

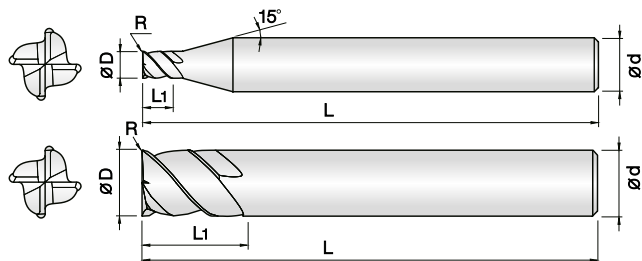

- Určeno pro kalené oceli (50–62 HRC)
- Vysoká odolnost proti opotřeбенí díky PVD povlaku na bázi Si
- Velmi přesné tolerance řezných hran
- Vyšší posuvy díky 45° geometrii
- Vynikající výkon při vysokých řezných rychlostech díky 0,2 μm tvrdokovu



NOVINKA

Objednací číslo	D (mm)	R (mm)	L1 (mm)	L (mm)	d h5 (mm)	Standardní položka
4CRL-010-0005-S06	1	R 0,05	2	50	6	☑
4CRL-010-001-S06		R 0,1	2	50	6	☑
4CRL-010-002-S06		R 0,2	2	50	6	☑
4CRL-010-003-S06		R 0,3	2	50	6	☑
4CRL-012-0005-S06	1,2	R 0,05	2,5	50	6	☑
4CRL-012-001-S06		R 0,1	2,5	50	6	☑
4CRL-012-002-S06		R 0,2	2,5	50	6	☑
4CRL-012-003-S06		R 0,3	2,5	50	6	☑
4CRL-015-0005-S06	1,5	R 0,05	3	50	6	☑
4CRL-015-001-S06		R 0,1	3	50	6	☑
4CRL-015-002-S06		R 0,2	3	50	6	☑
4CRL-015-003-S06		R 0,3	3	50	6	☑
4CRL-015-005-S06		R 0,5	3	50	6	☑
4CRL-020-001-S06	2	R 0,1	5	50	6	☑
4CRL-020-002-S06		R 0,2	5	50	6	☑
4CRL-020-003-S06		R 0,3	5	50	6	☑
4CRL-020-005-S06		R 0,5	5	50	6	☑
4CRL-025-001-S06	2,5	R 0,1	6	60	6	☑
4CRL-025-002-S06		R 0,2	6	60	6	☑
4CRL-025-003-S06		R 0,3	6	60	6	☑
4CRL-025-005-S06		R 0,5	6	60	6	☑
4CRL-030-001-S06	3	R 0,1	6	70	6	☑
4CRL-030-002-S06		R 0,2	6	70	6	☑
4CRL-030-003-S06		R 0,3	6	70	6	☑
4CRL-030-005-S06		R 0,5	6	70	6	☑
4CRL-030-010-S06		R 1	6	70	6	☑
4CRL-040-001-S06	4	R 0,1	8	70	6	☑
4CRL-040-002-S06		R 0,2	8	70	6	☑
4CRL-040-003-S06		R 0,3	8	70	6	☑
4CRL-040-005-S06		R 0,5	8	70	6	☑
4CRL-040-010-S06		R 1	8	70	6	☑
4CRL-050-001-S06	5	R 0,1	10	80	6	☑
4CRL-050-002-S06		R 0,2	10	80	6	☑
4CRL-050-003-S06		R 0,3	10	80	6	☑
4CRL-050-005-S06		R 0,5	10	80	6	☑
4CRL-050-010-S06		R 1	10	80	6	☑
4CRL-060-001-S06	6	R 0,1	12	90	6	☑
4CRL-060-002-S06		R 0,2	12	90	6	☑

Objednací číslo	D (mm)	R (mm)	L1 (mm)	L (mm)	d h5 (mm)	Standardní položka
4CRL-060-003-S06	6	R 0,3	12	90	6	☑
4CRL-060-005-S06		R 0,5	12	90	6	☑
4CRL-060-010-S06		R 1	12	90	6	☑
4CRL-060-015-S06		R 1,5	12	90	6	☑
4CRL-060-020-S06		R 2	12	90	6	☑
4CRL-080-002-S08	8	R 0,2	16	90	8	☑
4CRL-080-003-S08		R 0,3	16	90	8	☑
4CRL-080-005-S08		R 0,5	16	90	8	☑
4CRL-080-010-S08		R 1	16	90	8	☑
4CRL-080-015-S08		R 1,5	16	90	8	☑
4CRL-080-020-S08		R 2	16	90	8	☑
4CRL-100-002-S10	10	R 0,2	20	100	10	☑
4CRL-100-003-S10		R 0,3	20	100	10	☑
4CRL-100-005-S10		R 0,5	20	100	10	☑
4CRL-100-010-S10		R 1	20	100	10	☑
4CRL-100-015-S10		R 1,5	20	100	10	☑
4CRL-100-020-S10		R 2	20	100	10	☑
4CRL-120-003-S12	12	R 0,3	24	110	12	☑
4CRL-120-005-S12		R 0,5	24	110	12	☑
4CRL-120-010-S12		R 1	24	110	12	☑
4CRL-120-015-S12		R 1,5	24	110	12	☑
4CRL-120-020-S12		R 2	24	110	12	☑
4CRL-120-030-S12		R 3	24	110	12	☑
4CRL-160-005-S16	16	R 0,5	32	120	16	☑
4CRL-160-010-S16		R 1	32	120	16	☑
4CRL-160-020-S16		R 2	32	120	16	☑
4CRL-160-030-S16		R 3	32	120	16	☑
4CRL-200-005-S20	20	R 0,5	38	130	20	☑
4CRL-200-010-S20		R 1	38	130	20	☑
4CRL-200-020-S20		R 2	38	130	20	☑
4CRL-200-030-S20		R 3	38	130	20	☑
4CRL-200-040-S20		R 4	38	130	20	☑
4CRL-200-050-S20		R 5	38	130	20	☑

6CRL

6-břité TOROIDNÍ frézy 45° pro kalené oceli do HRC 62

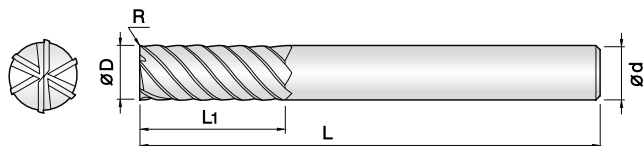

- ▶ Určeno pro kalené oceli (50–62 HRC)
- ▶ Vysoká odolnost proti opotřeбенí díky PVD povlaku na bázi Si
- ▶ Velmi přesné tolerance řezných hran
- ▶ Vyšší posuvy díky 45° geometrii
- ▶ Vynikající výkon při vysokých řezných rychlostech díky 0,2 μm tvrdokovu

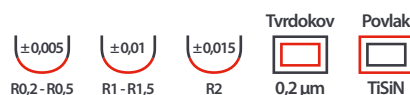
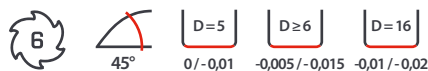

NOVINKA

Objednací číslo	D (mm)	R (mm)	L1 (mm)	L (mm)	d h5 (mm)	Standardní položka	
6CRL-030-001-060	3	R 0,1	7,5	60	6	☑	
6CRL-030-002-060		R 0,2	7,5	60	6	☑	
6CRL-030-003-060		R 0,3	7,5	60	6	☑	
6CRL-030-005-060		R 0,5	7,5	60	6	☑	
6CRL-030-010-060		R 1	7,5	60	6	☑	
6CRL-040-001-060	4	R 0,1	10	60	6	☑	
6CRL-040-002-060		R 0,2	10	60	6	☑	
6CRL-040-003-060		R 0,3	10	60	6	☑	
6CRL-040-005-060		R 0,5	10	60	6	☑	
6CRL-040-010-060		R 1	10	60	6	☑	
6CRL-050-002-060	5	R 0,2	13	60	6	☑	
6CRL-050-003-060		R 0,3	13	60	6	☑	
6CRL-050-005-060		R 0,5	13	60	6	☑	
6CRL-050-010-060		R 1	13	60	6	☑	
6CRL-060-001-060		6	R 0,1	15	60	6	☑
6CRL-060-002-060	R 0,2		15	60	6	☑	
6CRL-060-002-080			15	80	6	☑	
6CRL-060-003-060	R 0,3		15	60	6	☑	
6CRL-060-003-080			15	80	6	☑	
6CRL-060-005-060	R 0,5		15	60	6	☑	
6CRL-060-005-080			15	80	6	☑	
6CRL-060-010-060	R 1		15	60	6	☑	
6CRL-060-010-080			15	80	6	☑	
6CRL-080-002-070	8		R 0,2	20	70	8	☑
6CRL-080-003-070		R 0,3	20	70	8	☑	
6CRL-080-003-090			20	90	8	☑	
6CRL-080-005-070		R 0,5	20	70	8	☑	
6CRL-080-005-090			20	90	8	☑	
6CRL-080-010-070		R 1	20	70	8	☑	
6CRL-080-010-090			20	90	8	☑	
6CRL-080-015-070		R 1,5	20	70	8	☑	
6CRL-100-002-075		10	R 0,2	20	75	10	☑
6CRL-100-003-075			R 0,3	25	75	10	☑
6CRL-100-003-100	25			100	10	☑	
6CRL-100-005-075	R 0,5		25	75	10	☑	
6CRL-100-005-100			25	100	10	☑	
6CRL-100-010-075	R 1		25	75	10	☑	
6CRL-100-010-100			25	100	10	☑	

Objednací číslo	D (mm)	R (mm)	L1 (mm)	L (mm)	d h5 (mm)	Standardní položka	
6CRL-100-020-075	10	R 2	25	75	10	☑	
6CRL-120-002-080	12	R 0,2	25	80	12	☑	
6CRL-120-003-080		R 0,3	30	80	12	☑	
6CRL-120-003-110			30	110	12	☑	
6CRL-120-005-080		R 0,5	30	80	12	☑	
6CRL-120-005-110			30	110	12	☑	
6CRL-120-010-080		R 1	30	80	12	☑	
6CRL-120-010-110			30	110	12	☑	
6CRL-120-020-080		R 2	30	80	12	☑	
6CRL-160-005-110		16	R 0,5	50	110	16	☑
6CRL-160-010-110			R 1	50	110	16	☑
6CRL-160-020-110	R 2		50	110	16	☑	

4RCU 4-břité TOROIDNÍ frézy 15° pro kalené oceli do HRC 60

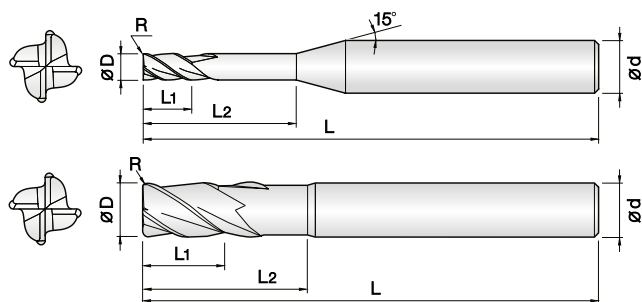

- ▶ Určeno pro kalené oceli (50–60 HRC)
- ▶ Vysoká odolnost proti opotřeбенí díky PVD povlaku na bázi Si
- ▶ Určeno pro vysoké posuvy při nižších řezných rychlostech
- ▶ Vhodné pro náročné a hrubovací obrábění
- ▶ Minimalizace vyštipování díky tvrdokovu s vysokou houževnatostí

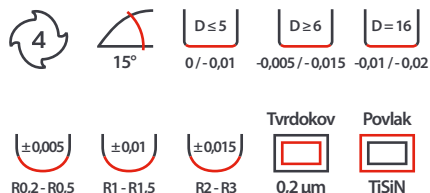

Objednací číslo	D (mm)	R (mm)	L2 (mm)	L1 (mm)	L (mm)	d h5 (mm)	Standardní položka
4RCU-010-002-025	1	R 0,2	2,5	1	50	4	☑
4RCU-015-005-040	1,5	R 0,5	4	1,5	50	4	☑
4RCU-020-005-060	2	R 0,5	6	2	50	6	☑
4RCU-030-005-080	3	R 0,5	8	3	50	6	☑
4RCU-040-005-120	4	R 0,5	12	4	60	6	☑
4RCU-040-005-160			16	4	60	6	☑
4RCU-040-010-120	4	R 1	12	4	60	6	☑
4RCU-040-010-160			16	4	60	6	☑
4RCU-050-005-150	5	R 0,5	15	5	60	6	☑
4RCU-050-010-150		R 1	15	5	60	6	☑
4RCU-060-003-150	6	R 0,3	15	6	60	6	☑
4RCU-060-005-150		R 0,5	15	6	60	6	☑
4RCU-060-010-150		R 1	15	6	60	6	☑
4RCU-060-015-150		R 1,5	15	6	60	6	☑
4RCU-080-003-160	8	R 0,3	16	8	60	8	☑
4RCU-080-005-160			16	8	60	8	☑
4RCU-080-005-200		R 0,5	20	8	80	8	☑
4RCU-080-005-300			30	8	110	8	☑
4RCU-080-010-160		R 1	16	8	60	8	☑
4RCU-080-010-200			20	8	80	8	☑
4RCU-080-010-300			30	8	110	8	☑
4RCU-080-020-160			R 2	16	8	60	8
4RCU-080-020-200	20	8		80	8	☑	
4RCU-080-020-300	30	8	110	8	☑		
4RCU-100-003-200	10	R 0,3	20	10	70	10	☑
4RCU-100-005-200			20	10	70	10	☑
4RCU-100-005-250			R 0,5	25	10	90	10
4RCU-100-005-300		30		10	120	10	☑
4RCU-100-010-200		R 1	20	10	70	10	☑
4RCU-100-010-250			25	10	90	10	☑
4RCU-100-010-300			30	10	120	10	☑
4RCU-100-020-200		R 2	20	10	70	10	☑
4RCU-100-020-250			25	10	90	10	☑
4RCU-100-020-300			30	10	120	10	☑
4RCU-120-005-250	12		R 0,5	25	12	80	12
4RCU-120-005-300		30		12	100	12	☑
4RCU-120-005-350		R 1	35	12	130	12	☑
4RCU-120-010-250			25	12	80	12	☑

Objednací číslo	D (mm)	R (mm)	L2 (mm)	L1 (mm)	L (mm)	d h5 (mm)	Standardní položka
4RCU-120-010-300	12	R 1	30	12	100	12	☑
4RCU-120-010-350			35	12	130	12	☑
4RCU-120-020-250		R 2	25	12	80	12	☑
4RCU-120-020-300			30	12	100	12	☑
4RCU-120-020-350		R 3	35	12	130	12	☑
4RCU-120-030-250			25	12	80	12	☑
4RCU-160-010-300	16	R 1	30	16	110	16	☑
4RCU-160-010-400			40	16	160	16	☑
4RCU-160-020-300		R 2	30	16	110	16	☑
4RCU-160-020-400			40	16	160	16	☑

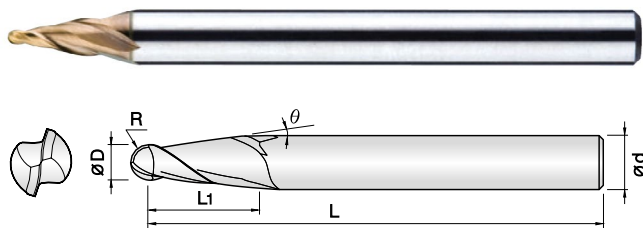

- Určeno pro kalené oceli (45–55 HRC)
- Vysoká odolnost proti opotřebení díky PVD povlaku na bázi Si
- Velmi přesné tolerance řezných hran
- Zesílená řezná hrana pro minimalizaci vyštipování
- Vynikající výkon při vysokých řezných rychlostech díky 0,5 μm tvrdokovu

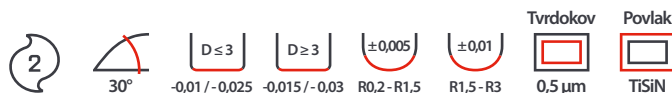

NOVINKA

Objednací číslo	D (mm)	R (mm)	Úhel θ	L1 (mm)	L (mm)	d h5 (mm)	Standardní položka
2CTB-002-010-015	0,2	R 0,1	1°	1,5	40	4	☑
2CTB-002-020-015			2°	1,5	40	4	☑
2CTB-002-030-015			3°	1,5	40	4	☑
2CTB-002-050-015			5°	1,5	40	4	☑
2CTB-002-070-015			7°	1,5	40	4	☑
2CTB-002-100-015			10°	1,5	40	4	☑
2CTB-003-010-020	0,3	R 0,15	1°	2	40	4	☑
2CTB-003-020-020			2°	2	40	4	☑
2CTB-003-030-020			3°	2	40	4	☑
2CTB-003-050-020			5°	2	40	4	☑
2CTB-003-070-020			7°	2	40	4	☑
2CTB-003-100-020			10°	2	40	4	☑
2CTB-003-150-020	0,4	R 0,2	15°	2	40	4	☑
2CTB-004-010-030			1°	3	40	4	☑
2CTB-004-020-030			2°	3	40	4	☑
2CTB-004-030-030			3°	3	40	4	☑
2CTB-004-040-030			4°	3	40	4	☑
2CTB-004-050-030			5°	3	40	4	☑
2CTB-004-070-030	0,5	R 0,25	7°	3	40	4	☑
2CTB-004-100-030			10°	3	40	4	☑
2CTB-004-150-030			15°	3	40	4	☑
2CTB-005-010-030			1°	3	40	4	☑
2CTB-005-020-030			2°	3	40	4	☑
2CTB-005-030-030			3°	3	40	4	☑
2CTB-005-040-035	0,6	R 0,3	4°	3,5	40	4	☑
2CTB-005-050-035			5°	3,5	40	4	☑
2CTB-005-070-035			7°	3,5	40	4	☑
2CTB-005-100-035			10°	3,5	40	4	☑
2CTB-005-150-035			15°	3,5	40	4	☑
2CTB-006-010-030			1°	3	40	4	☑
2CTB-006-020-030	2°	3	40	4	☑		
2CTB-006-030-030	0,7	R 0,35	3°	3	40	4	☑
2CTB-006-040-035			4°	3,5	40	4	☑
2CTB-006-050-035			5°	3,5	40	4	☑
2CTB-006-070-035			7°	3,5	40	4	☑
2CTB-006-100-035			10°	3,5	40	4	☑
2CTB-006-150-035			15°	3,5	40	4	☑
2CTB-007-010-030			1°	3	40	4	☑

Objednací číslo	D (mm)	R (mm)	Úhel θ	L1 (mm)	L (mm)	d h5 (mm)	Standardní položka
2CTB-007-020-030	0,7	R 0,35	2°	3	40	4	☑
2CTB-007-030-040			3°	4	40	4	☑
2CTB-007-050-040			5°	4	40	4	☑
2CTB-007-070-040			7°	4	40	4	☑
2CTB-007-100-040			10°	4	40	4	☑
2CTB-007-150-040			15°	4	40	4	☑
2CTB-008-010-030	0,8	R 0,4	1°	3	40	4	☑
2CTB-008-020-030			2°	3	40	4	☑
2CTB-008-030-030			3°	3	40	4	☑
2CTB-008-040-040			4°	4	40	4	☑
2CTB-008-050-040			5°	4	40	4	☑
2CTB-008-070-040			7°	4	40	4	☑
2CTB-008-100-040	1	R 0,5	10°	4	40	4	☑
2CTB-008-150-040			15°	4	40	4	☑
2CTB-010-003-030			0°30'	3	40	4	☑
2CTB-010-010-030			1°	3	40	4	☑
2CTB-010-013-040			1°30'	4	40	4	☑
2CTB-010-020-040			2°	4	40	4	☑
2CTB-010-030-040	1,2	R 0,6	3°	4	40	4	☑
2CTB-010-040-060			4°	6	45	4	☑
2CTB-010-050-060			5°	6	45	4	☑
2CTB-010-070-060			7°	6	45	4	☑
2CTB-010-100-060			10°	6	45	4	☑
2CTB-010-150-056			15°	5,6	45	4	☑
2CTB-012-003-030	1,5	R 0,75	0°30'	3	40	4	☑
2CTB-012-010-030			1°	3	40	4	☑
2CTB-012-013-040			1°30'	4	40	4	☑
2CTB-012-020-040			2°	4	40	4	☑
2CTB-012-030-040			3°	4	40	4	☑
2CTB-012-040-060			4°	6	45	4	☑
2CTB-012-050-060	1,5	R 0,75	5°	6	45	4	☑
2CTB-012-070-060			7°	6	45	4	☑
2CTB-012-100-060			10°	6	45	4	☑
2CTB-012-150-050			15°	5	45	4	☑
2CTB-015-003-060			0°30'	6	45	4	☑
2CTB-015-010-060			1°	6	45	4	☑
2CTB-015-013-060	1°30'	6	45	4	☑		
2CTB-015-020-060	2°	6	45	4	☑		

NOVINKA

Objednací číslo	D (mm)	R (mm)	Úhel θ	L1 (mm)	L (mm)	d h5 (mm)	Standardní položka		
2CTB-015-030-060	1,5	R 0,75	3°	6	45	4	<input checked="" type="checkbox"/>		
2CTB-015-040-060			4°	6	45	4	<input checked="" type="checkbox"/>		
2CTB-015-050-060			5°	6	45	4	<input checked="" type="checkbox"/>		
2CTB-015-070-060			7°	6	45	4	<input checked="" type="checkbox"/>		
2CTB-015-100-060			10°	6	45	4	<input checked="" type="checkbox"/>		
2CTB-015-150-060			15°	6	50	6	<input checked="" type="checkbox"/>		
2CTB-020-003-080	2	R 1	0°30'	8	45	4	<input checked="" type="checkbox"/>		
2CTB-020-010-080			1°	8	45	4	<input checked="" type="checkbox"/>		
2CTB-020-013-080			1°30'	8	45	4	<input checked="" type="checkbox"/>		
2CTB-020-020-080			2°	8	45	4	<input checked="" type="checkbox"/>		
2CTB-020-030-080			3°	8	45	4	<input checked="" type="checkbox"/>		
2CTB-020-040-080			4°	8	45	4	<input checked="" type="checkbox"/>		
2CTB-020-050-080			5°	8	45	4	<input checked="" type="checkbox"/>		
2CTB-020-070-080			7°	8	45	4	<input checked="" type="checkbox"/>		
2CTB-020-100-080			10°	8	50	6	<input checked="" type="checkbox"/>		
2CTB-020-150-080			15°	8	50	6	<input checked="" type="checkbox"/>		
2CTB-030-003-120			3	R 1,5	0°30'	12	60	6	<input checked="" type="checkbox"/>
2CTB-030-010-120					1°	12	60	6	<input checked="" type="checkbox"/>
2CTB-030-013-120	1°30'	12			60	6	<input checked="" type="checkbox"/>		
2CTB-030-020-120	2°	12			60	6	<input checked="" type="checkbox"/>		
2CTB-030-030-120	3°	12			60	6	<input checked="" type="checkbox"/>		
2CTB-030-040-120	4°	12			60	6	<input checked="" type="checkbox"/>		
2CTB-030-050-120	5°	12			60	6	<input checked="" type="checkbox"/>		
2CTB-030-070-120	7°	12			60	6	<input checked="" type="checkbox"/>		
2CTB-030-100-120	10°	12			60	8	<input checked="" type="checkbox"/>		
2CTB-030-150-120	15°	12			70	10	<input checked="" type="checkbox"/>		
2CTB-040-003-160	4	R 2	0°30'	16	70	8	<input checked="" type="checkbox"/>		
2CTB-040-010-160			1°	16	70	8	<input checked="" type="checkbox"/>		
2CTB-040-013-160			1°30'	16	70	8	<input checked="" type="checkbox"/>		
2CTB-040-020-160			2°	16	70	8	<input checked="" type="checkbox"/>		
2CTB-040-030-160			3°	16	70	8	<input checked="" type="checkbox"/>		
2CTB-040-040-160			4°	16	70	8	<input checked="" type="checkbox"/>		
2CTB-040-050-160			5°	16	70	8	<input checked="" type="checkbox"/>		
2CTB-040-070-160			7°	16	70	8	<input checked="" type="checkbox"/>		
2CTB-040-100-160			10°	16	70	10	<input checked="" type="checkbox"/>		
2CTB-040-150-160			15°	16	80	12	<input checked="" type="checkbox"/>		
2CTB-050-003-200	5	R 2,5	0°30'	20	75	8	<input checked="" type="checkbox"/>		
2CTB-050-010-200			1°	20	75	8	<input checked="" type="checkbox"/>		
2CTB-050-013-200			1°30'	20	75	8	<input checked="" type="checkbox"/>		
2CTB-050-020-200			2°	20	75	8	<input checked="" type="checkbox"/>		
2CTB-050-030-200			3°	20	75	8	<input checked="" type="checkbox"/>		
2CTB-050-040-200			4°	20	75	8	<input checked="" type="checkbox"/>		
2CTB-050-050-200			5°	20	80	10	<input checked="" type="checkbox"/>		
2CTB-050-070-200			7°	20	80	10	<input checked="" type="checkbox"/>		
2CTB-060-003-240	6	R 3	0°30'	24	80	10	<input checked="" type="checkbox"/>		
2CTB-060-010-240			1°	24	80	10	<input checked="" type="checkbox"/>		
2CTB-060-013-240			1°30'	24	80	10	<input checked="" type="checkbox"/>		
2CTB-060-020-240	6	R 3	2°	24	80	10	<input checked="" type="checkbox"/>		
2CTB-060-030-240			3°	24	80	10	<input checked="" type="checkbox"/>		
2CTB-060-040-240			4°	24	80	10	<input checked="" type="checkbox"/>		
2CTB-060-050-240			5°	24	90	12	<input checked="" type="checkbox"/>		
2CTB-060-070-240			7°	24	90	12	<input checked="" type="checkbox"/>		

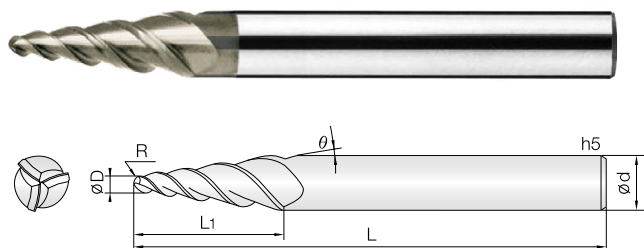

- Určeno pro obrábění ocelí, korozivzdorných ocelí, litiny, slitin hliníku a pro superslitiny (Inconel, ...)
- Zvýšená odolnost proti opotřebení díky novému AlCrN povlaku
- Vhodné pro tvarové obrábění rotorů, lopatek turbín, kompresorových kol a profilů pneumatik
- Možnost hrubování a dokončování jedním nástrojem

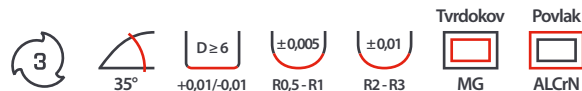

Objednací-číslo	D (mm)	R (mm)	Úhel θ	L1 (mm)	L (mm)	d h5 (mm)	Standardní položka	
3TBIC-010-010-120	1	R 0,5	1	12	50	6	☑	
3TBIC-010-010-200		R 0,5	1	20	60	6	☑	
3TBIC-010-020-150		R 0,5	2	15	55	6	☑	
3TBIC-010-020-200		R 0,5	2	20	60	6	☑	
3TBIC-010-030-150		R 0,5	3	15	55	6	☑	
3TBIC-010-030-200		R 0,5	3	20	60	6	☑	
3TBIC-010-040-200		R 0,5	4	20	60	6	☑	
3TBIC-010-050-200		R 0,5	5	20	60	6	☑	
3TBIC-010-060-200		R 0,5	6	20	60	6	☑	
3TBIC-010-070-200		R 0,5	7	20	60	6	☑	
3TBIC-010-080-180		R 0,5	8	18	60	6	☑	
3TBIC-020-010-120		2	R 1	1	12	50	6	☑
3TBIC-020-010-200			R 1	1	20	60	6	☑
3TBIC-020-020-150	R 1		2	15	55	6	☑	
3TBIC-020-020-200	R 1		2	20	60	6	☑	
3TBIC-020-030-150	R 1		3	15	55	6	☑	
3TBIC-020-030-200	R 1		3	20	60	6	☑	
3TBIC-020-030-300	R 1		3	30	70	6	☑	
3TBIC-020-040-200	R 1		4	20	60	6	☑	
3TBIC-020-050-200	R 1		5	20	60	6	☑	
3TBIC-020-050-300	R 1		5	30	75	8	☑	
3TBIC-020-060-190	R 1		6	19	60	6	☑	
3TBIC-020-060-290	R 1		6	29	75	8	☑	
3TBIC-020-070-160	R 1		7	16	60	6	☑	
3TBIC-020-070-250	R 1		7	25	70	8	☑	
3TBIC-020-080-150	R 1		8	15	60	6	☑	
3TBIC-020-080-220	R 1		8	22	70	8	☑	
3TBIC-030-010-200	3		R 1,5	1	20	60	6	☑
3TBIC-030-010-320		R 1,5	1	32	75	6	☑	
3TBIC-030-020-200		R 1,5	2	20	60	6	☑	
3TBIC-030-030-200		R 1,5	3	20	60	6	☑	
3TBIC-030-030-300		R 1,5	3	30	70	6	☑	
3TBIC-030-030-390		R 1,5	3	39	80	8	☑	
3TBIC-030-040-200		R 1,5	4	20	65	6	☑	
3TBIC-030-050-180		R 1,5	5	18	60	6	☑	
3TBIC-030-050-300		R 1,5	5	30	75	8	☑	
3TBIC-030-060-150		R 1,5	6	15	60	6	☑	
3TBIC-030-060-250		R 1,5	6	25	70	8	☑	

Objednací-číslo	D (mm)	R (mm)	Úhel θ	L1 (mm)	L (mm)	d h5 (mm)	Standardní položka
3TBIC-030-070-190	3	R 1,5	7	19	70	8	☑
3TBIC-030-070-300		R 1,5	7	30	80	10	☑
3TBIC-030-080-190		R 1,5	8	19	70	8	☑
3TBIC-030-080-260		R 1,5	8	26	75	10	☑
3TBIC-040-010-200	4	R 2	1	20	60	6	☑
3TBIC-040-010-320		R 2	1	32	75	6	☑
3TBIC-040-020-200		R 2	2	20	60	6	☑
3TBIC-040-020-300		R 2	2	30	70	6	☑
3TBIC-040-030-210		R 2	3	21	70	6	☑
3TBIC-040-030-320		R 2	3	32	80	8	☑
3TBIC-040-030-400		R 2	3	40	90	8	☑
3TBIC-040-040-200		R 2	4	20	70	8	☑
3TBIC-040-040-300		R 2	4	30	75	8	☑
3TBIC-040-050-200		R 2	5	20	70	8	☑
3TBIC-040-050-320		R 2	5	32	80	10	☑
3TBIC-040-060-200		R 2	6	20	70	8	☑
3TBIC-040-060-300		R 2	6	30	80	10	☑
3TBIC-040-070-180		R 2	7	18	70	8	☑
3TBIC-040-070-260		R 2	7	26	80	10	☑
3TBIC-040-080-230		R 2	8	23	75	10	☑
3TBIC-060-010-320	6	R 3	1	32	75	8	☑
3TBIC-060-020-300		R 3	2	30	75	8	☑
3TBIC-060-030-220		R 3	3	22	75	8	☑
3TBIC-060-030-320		R 3	3	32	80	10	☑
3TBIC-060-030-400		R 3	3	40	90	10	☑
3TBIC-060-040-250		R 3	4	25	75	10	☑
3TBIC-060-040-310		R 3	4	31	80	10	☑
3TBIC-060-050-210		R 3	5	21	75	10	☑
3TBIC-060-050-320		R 3	5	32	80	12	☑
3TBIC-060-060-210		R 3	6	21	75	10	☑
3TBIC-060-060-310		R 3	6	31	80	12	☑
3TBIC-060-070-190		R 3	7	19	75	10	☑
3TBIC-060-070-270	R 3	7	27	80	12	☑	

2CTE 2-břité KUŽELOVÉ ostré frézy pro kalené oceli do HRC 55

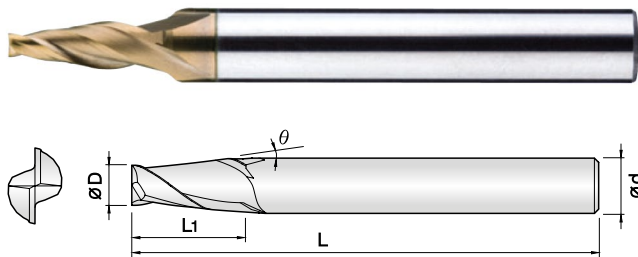

- Určeno pro kalené oceli (45–55 HRC)
- Vysoká odolnost proti opotřebení díky PVD povlaku na bázi Si
- Velmi přesné tolerance řezných hran
- Zesílená řezná hrana pro minimalizaci vyštipování
- Vynikající výkon při vysokých řezných rychlostech díky 0,5 μm tvrdokovu



NOVINKA

Objednací číslo	D (mm)	Úhel θ	L1 (mm)	L (mm)	d h5 (mm)	Standardní položka
2CTE-002-003-010	0,2	0°30'	1	40	4	☑
2CTE-002-010-010		1°	1	40	4	☑
2CTE-002-013-010		1°30'	1	40	4	☑
2CTE-002-020-010		2°	1	40	4	☑
2CTE-002-030-010		3°	1	40	4	☑
2CTE-002-050-010		5°	1	40	4	☑
2CTE-002-070-010		7°	1	40	4	☑
2CTE-002-100-010		10°	1	40	4	☑
2CTE-002-150-010		15°	1	40	4	☑
2CTE-003-003-012		0,3	0°30'	1,2	40	4
2CTE-003-010-012	1°		1,2	40	4	☑
2CTE-003-013-012	1°30'		1,2	40	4	☑
2CTE-003-020-012	2°		1,2	40	4	☑
2CTE-003-030-012	3°		1,2	40	4	☑
2CTE-003-050-012	5°		1,2	40	4	☑
2CTE-003-070-015	7°		1,5	40	4	☑
2CTE-003-100-015	10°		1,5	40	4	☑
2CTE-003-150-015	15°		1,5	40	4	☑
2CTE-004-003-016	0,4		0°30'	1,6	40	4
2CTE-004-010-016		1°	1,6	40	4	☑
2CTE-004-013-016		1°30'	1,6	40	4	☑
2CTE-004-020-016		2°	1,6	40	4	☑
2CTE-004-030-016		3°	1,6	40	4	☑
2CTE-004-050-016		5°	1,6	40	4	☑
2CTE-004-070-020		7°	2	40	4	☑
2CTE-004-100-020		10°	2	40	4	☑
2CTE-004-150-020		15°	2	40	4	☑
2CTE-005-003-020		0,5	0°30'	2	40	4
2CTE-005-010-020	1°		2	40	4	☑
2CTE-005-013-020	1°30'		2	40	4	☑
2CTE-005-020-020	2°		2	40	4	☑
2CTE-005-030-020	3°		2	40	4	☑
2CTE-005-050-020	5°		2	40	4	☑
2CTE-005-070-025	7°		2,5	40	4	☑
2CTE-005-100-025	10°		2,5	40	4	☑
2CTE-005-150-025	15°		2,5	40	4	☑
2CTE-005-200-025	20°		2,5	40	4	☑
2CTE-006-003-020	0,6	0°30'	2	40	4	☑

Objednací číslo	D (mm)	Úhel θ	L1 (mm)	L (mm)	d h5 (mm)	Standardní položka
2CTE-006-003-020	0,6	1°	2	40	4	☑
2CTE-006-013-020		1°30'	2	40	4	☑
2CTE-006-020-020		2°	2	40	4	☑
2CTE-006-030-020		3°	2	40	4	☑
2CTE-006-050-020		5°	2	40	4	☑
2CTE-006-070-025		7°	2,5	40	4	☑
2CTE-006-100-025		10°	2,5	40	4	☑
2CTE-006-150-025		15°	2,5	40	4	☑
2CTE-006-200-025		20°	2,5	40	4	☑
2CTE-007-010-025		0,7	1°	2,5	40	4
2CTE-007-013-025	1°30'		2,5	40	4	☑
2CTE-007-020-025	2°		2,5	40	4	☑
2CTE-007-030-025	3°		2,5	40	4	☑
2CTE-007-050-025	5°		2,5	40	4	☑
2CTE-007-070-030	7°		3	40	4	☑
2CTE-007-100-030	10°		3	40	4	☑
2CTE-007-150-030	15°		3	40	4	☑
2CTE-007-200-030	20°		3	40	4	☑
2CTE-008-003-030	0,8		0°30'	3	40	4
2CTE-008-010-030		1°	3	40	4	☑
2CTE-008-013-030		1°30'	3	40	4	☑
2CTE-008-020-030		2°	3	40	4	☑
2CTE-008-030-030		3°	3	40	4	☑
2CTE-008-050-030		5°	3	40	4	☑
2CTE-008-070-030		7°	3	40	4	☑
2CTE-008-100-030		10°	3	40	4	☑
2CTE-008-150-030		15°	3	40	4	☑
2CTE-008-200-030		20°	3	40	4	☑
2CTE-010-003-040	1	0°30'	4	45	4	☑
2CTE-010-010-040		1°	4	45	4	☑
2CTE-010-013-040		1°30'	4	45	4	☑
2CTE-010-020-040		2°	4	45	4	☑
2CTE-010-030-040		3°	4	45	4	☑
2CTE-010-050-040		5°	4	45	4	☑
2CTE-010-070-040		7°	4	45	4	☑
2CTE-010-100-040		10°	4	45	4	☑
2CTE-010-150-040		15°	4	50	4	☑
2CTE-010-200-040		20°	4	50	4	☑

NOVINKA

Objednací číslo	D (mm)	Úhel θ	L1 (mm)	L (mm)	d h5 (mm)	Standardní položka
2CTE-015-003-050	1,5	0°30'	5	45	4	<input checked="" type="checkbox"/>
2CTE-015-010-050		1°	5	45	4	<input checked="" type="checkbox"/>
2CTE-015-013-060		1°30'	6	45	4	<input checked="" type="checkbox"/>
2CTE-015-020-070		2°	7	45	4	<input checked="" type="checkbox"/>
2CTE-015-030-080		3°	8	45	4	<input checked="" type="checkbox"/>
2CTE-015-050-100		5°	10	50	4	<input checked="" type="checkbox"/>
2CTE-015-070-100		7°	10	50	4	<input checked="" type="checkbox"/>
2CTE-015-100-100		10°	10	50	6	<input checked="" type="checkbox"/>
2CTE-015-150-060		15°	6	50	6	<input checked="" type="checkbox"/>
2CTE-015-200-060		20°	6	50	6	<input checked="" type="checkbox"/>
2CTE-020-003-060	2	0°30'	6	45	4	<input checked="" type="checkbox"/>
2CTE-020-010-060		1°	6	45	4	<input checked="" type="checkbox"/>
2CTE-020-013-060		1°30'	6	45	4	<input checked="" type="checkbox"/>
2CTE-020-020-080		2°	8	45	4	<input checked="" type="checkbox"/>
2CTE-020-030-100		3°	10	50	4	<input checked="" type="checkbox"/>
2CTE-020-050-100		5°	10	50	4	<input checked="" type="checkbox"/>
2CTE-020-070-100		7°	10	50	6	<input checked="" type="checkbox"/>
2CTE-020-100-110		10°	11	50	6	<input checked="" type="checkbox"/>
2CTE-020-150-070		15°	7	50	6	<input checked="" type="checkbox"/>
2CTE-020-200-070		20°	7	50	8	<input checked="" type="checkbox"/>
2CTE-025-003-080	2,5	0°30'	8	45	6	<input checked="" type="checkbox"/>
2CTE-025-010-100		1°	10	50	6	<input checked="" type="checkbox"/>
2CTE-025-013-100		1°30'	10	50	6	<input checked="" type="checkbox"/>
2CTE-025-020-120		2°	12	50	6	<input checked="" type="checkbox"/>
2CTE-025-030-120	2,5	3°	12	50	6	<input checked="" type="checkbox"/>
2CTE-025-050-120		5°	12	50	6	<input checked="" type="checkbox"/>
2CTE-025-070-120		7°	12	50	6	<input checked="" type="checkbox"/>
2CTE-025-100-100		10°	10	50	6	<input checked="" type="checkbox"/>
2CTE-025-150-100		15°	10	60	6	<input checked="" type="checkbox"/>
2CTE-025-200-100		20°	10	70	8	<input checked="" type="checkbox"/>
2CTE-030-003-120	3	0°30'	12	50	10	<input checked="" type="checkbox"/>
2CTE-030-010-120		1°	12	50	6	<input checked="" type="checkbox"/>
2CTE-030-013-120		1°30'	12	50	6	<input checked="" type="checkbox"/>
2CTE-030-020-120		2°	12	50	6	<input checked="" type="checkbox"/>
2CTE-030-030-120		3°	12	50	6	<input checked="" type="checkbox"/>
2CTE-030-050-120		5°	12	50	6	<input checked="" type="checkbox"/>
2CTE-030-070-120		7°	12	50	6	<input checked="" type="checkbox"/>
2CTE-030-100-080		10°	8	50	6	<input checked="" type="checkbox"/>
2CTE-030-150-090		15°	9	60	8	<input checked="" type="checkbox"/>
2CTE-030-200-090		20°	9	70	10	<input checked="" type="checkbox"/>
2CTE-040-003-150	4	0°30'	15	60	6	<input checked="" type="checkbox"/>
2CTE-040-010-150		1°	15	60	6	<input checked="" type="checkbox"/>
2CTE-040-013-150		1°30'	15	60	6	<input checked="" type="checkbox"/>
2CTE-040-020-150		2°	15	60	6	<input checked="" type="checkbox"/>
2CTE-040-030-180		3°	18	60	6	<input checked="" type="checkbox"/>
2CTE-040-050-230		5°	23	65	8	<input checked="" type="checkbox"/>
2CTE-040-070-240		7°	24	75	10	<input checked="" type="checkbox"/>
2CTE-040-100-220		10°	22	75	12	<input checked="" type="checkbox"/>
2CTE-060-003-200	6	0°30'	20	65	8	<input checked="" type="checkbox"/>
2CTE-060-010-200		1°	20	65	8	<input checked="" type="checkbox"/>
2CTE-060-013-200		1°30'	20	65	8	<input checked="" type="checkbox"/>
2CTE-060-020-200		2°	20	65	8	<input checked="" type="checkbox"/>

Objednací číslo	D (mm)	Úhel θ	L1 (mm)	L (mm)	d h5 (mm)	Standardní položka
2CTE-060-030-190	6	3°	19	65	8	<input checked="" type="checkbox"/>
2CTE-060-050-230		5°	23	75	10	<input checked="" type="checkbox"/>
2CTE-060-070-240		7°	24	75	12	<input checked="" type="checkbox"/>
2CTE-060-100-170		10°	17	75	12	<input checked="" type="checkbox"/>
2CTE-070-003-250	7	0°30'	25	70	8	<input checked="" type="checkbox"/>
2CTE-070-010-250		1°	25	70	8	<input checked="" type="checkbox"/>
2CTE-070-013-250		1°30'	25	70	10	<input checked="" type="checkbox"/>
2CTE-070-030-280		3°	28	80	10	<input checked="" type="checkbox"/>
2CTE-070-050-280	8	5°	28	80	12	<input checked="" type="checkbox"/>
2CTE-080-003-320		0°30'	32	90	10	<input checked="" type="checkbox"/>
2CTE-080-010-350		1°	35	90	10	<input checked="" type="checkbox"/>
2CTE-080-013-350		1°30'	35	90	10	<input checked="" type="checkbox"/>
2CTE-080-020-280		2°	28	75	10	<input checked="" type="checkbox"/>
2CTE-080-030-350		3°	35	90	12	<input checked="" type="checkbox"/>
2CTE-080-050-450		5°	45	100	16	<input checked="" type="checkbox"/>
2CTE-080-070-320		7°	32	90	16	<input checked="" type="checkbox"/>
2CTE-080-100-340	10°	34	100	20	<input checked="" type="checkbox"/>	

4CTE 4-břité KUŽELOVÉ ostré frézy pro kalené oceli do HRC 55

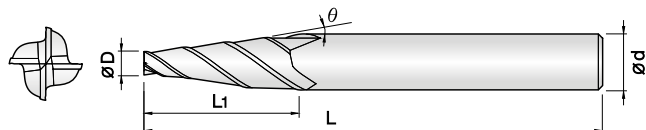

- Určeno pro kalené oceli (45–55 HRC)
- Vysoká odolnost proti opotřebení díky PVD povlaku na bázi Si
- Velmi přesné tolerance řezných hran
- Zesílená řezná hrana pro minimalizaci vyštipování
- Vynikající výkon při vysokých řezných rychlostech díky 0,5 μm tvrdokovu



NOVINKA

Objednací číslo	D (mm)	Úhel θ	L1 (mm)	L (mm)	d h5 (mm)	Standardní položka
4CTE-030-003-110	3	0°30'	11	50	6	☑
4CTE-030-010-110		1°	11	50	6	☑
4CTE-030-013-110		1°30'	11	50	6	☑
4CTE-030-020-150		2°	15	60	6	☑
4CTE-030-023-150		2°30'	15	60	6	☑
4CTE-030-030-150		3°	15	60	6	☑
4CTE-030-050-150		5°	15	60	6	☑
4CTE-030-070-120		7°	12	60	6	☑
4CTE-030-100-190		10°	19	80	10	☑
4CTE-040-003-150		4	0°30'	15	60	6
4CTE-040-010-150	1°		15	60	6	☑
4CTE-040-013-150	1°30'		15	60	6	☑
4CTE-040-020-180	2°		18	60	6	☑
4CTE-040-023-180	2°30'		18	60	6	☑
4CTE-040-030-180	3°		18	60	6	☑
4CTE-040-050-230	5°		23	65	8	☑
4CTE-040-070-250	7°		25	75	10	☑
4CTE-050-003-180	5	0°30'	18	60	6	☑
4CTE-050-010-180		1°	18	60	6	☑
4CTE-050-013-180		1°30'	18	60	6	☑
4CTE-050-020-150		2°	15	60	6	☑
4CTE-050-023-200		2°30'	20	65	8	☑
4CTE-050-030-210		3°	21	65	8	☑
4CTE-050-050-280		5°	28	80	10	☑
4CTE-050-070-280		7°	28	80	12	☑
4CTE-052-0147-120	5,2	1°47'	12	60	6	☑
4CTE-060-003-200	6	0°30'	20	65	8	☑
4CTE-060-010-200		1°	20	65	8	☑
4CTE-060-013-200		1°30'	20	65	8	☑
4CTE-060-020-200		2°	20	65	8	☑
4CTE-060-023-200		2°30'	20	65	8	☑
4CTE-060-030-260		3°	26	75	10	☑
4CTE-060-050-230		5°	23	75	10	☑
4CTE-060-070-240		7°	24	80	12	☑
4CTE-060-100-390		10°	39	110	20	☑
4CTE-080-003-250		8	0°30'	25	75	10
4CTE-080-010-250	1°		25	75	10	☑
4CTE-080-013-250	1°30'		25	75	10	☑

Objednací číslo	D (mm)	Úhel θ	L1 (mm)	L (mm)	d h5 (mm)	Standardní položka
4CTE-080-020-250	8	2°	25	75	10	☑
4CTE-080-023-230		2°30'	23	75	10	☑
4CTE-080-030-300		3°	30	80	12	☑
4CTE-080-050-230		5°	23	85	12	☑
4CTE-085-0147-240		8,5	1°47'	24	75	10
4CTE-100-003-300	10	0°30'	30	80	12	☑
4CTE-100-010-300		1°	30	80	12	☑
4CTE-100-013-300		1°30'	30	80	12	☑
4CTE-100-0147-320		1°47'	32	85	12	☑
4CTE-100-020-280		2°	28	80	12	☑
4CTE-100-030-400		3°	40	100	16	☑
4CTE-100-050-340		5°	34	100	16	☑

4RTE 4-břité KUŽELOVÉ ostré frézy pro žebrování pro kalené oceli do HRC 55

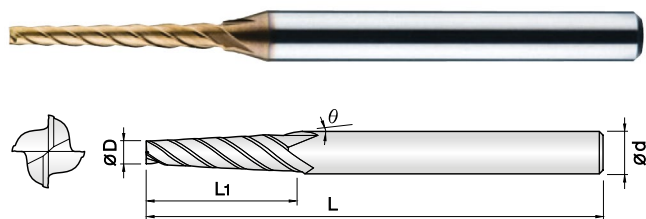

- Určeno pro kalené oceli (45–55 HRC)
- Vysoká odolnost proti opotřebení díky PVD povlaku na bázi Si
- Velmi přesné tolerance řezných hran
- Zesílená řezná hrana pro minimalizaci vyštipování
- Vynikající výkon při vysokých řezných rychlostech díky 0,5 μm tvrdokovu



Objednací číslo	D (mm)	Úhel θ	L1 (mm)	L (mm)	d h5 (mm)	Standardní položka
4RTE-005-030-040	0,5	0°30'	4	45	4	☑
4RTE-005-030-060			6	45	4	☑
4RTE-005-045-040		0°45'	4	45	4	☑
4RTE-005-045-060			6	45	4	☑
4RTE-005-100-040		1°	4	45	4	☑
4RTE-005-100-060			6	45	4	☑
4RTE-006-030-040	0,6	0°30'	4	45	4	☑
4RTE-006-030-060			6	45	4	☑
4RTE-006-045-040		0°45'	4	45	4	☑
4RTE-006-045-060			6	45	4	☑
4RTE-006-100-040		1°	4	45	4	☑
4RTE-006-100-060			6	45	4	☑
4RTE-007-030-060	0,7	0°30'	6	45	4	☑
4RTE-007-030-080			8	45	4	☑
4RTE-007-045-060		0°45'	6	45	4	☑
4RTE-007-045-080			8	45	4	☑
4RTE-007-100-060		1°	6	45	4	☑
4RTE-007-100-080			8	45	4	☑
4RTE-008-030-060	0,8	0°30'	6	45	4	☑
4RTE-008-030-080			8	45	4	☑
4RTE-008-030-100			10	45	4	☑
4RTE-008-045-060		0°45'	6	45	4	☑
4RTE-008-045-080			8	45	4	☑
4RTE-008-045-100			10	45	4	☑
4RTE-008-100-060	1°	6	45	4	☑	
4RTE-008-100-080		8	45	4	☑	
4RTE-008-100-100		10	45	4	☑	
4RTE-009-030-060	0,9	0°30'	6	45	4	☑
4RTE-009-030-080			8	45	4	☑
4RTE-009-030-100			10	45	4	☑
4RTE-009-045-060		0°45'	6	45	4	☑
4RTE-009-045-080			8	45	4	☑
4RTE-009-045-100			10	45	4	☑
4RTE-009-100-060	1°	6	45	4	☑	
4RTE-009-100-080		8	45	4	☑	
4RTE-009-100-100		10	45	4	☑	
4RTE-010-030-080	1	0°30'	8	45	4	☑
4RTE-010-030-100			10	45	4	☑

Objednací číslo	D (mm)	Úhel θ	L1 (mm)	L (mm)	d h5 (mm)	Standardní položka
4RTE-010-030-120	1	0°30'	12	45	4	☑
4RTE-010-045-080		0°45'	8	45	4	☑
4RTE-010-045-100			10	45	4	☑
4RTE-010-045-120			12	45	4	☑
4RTE-010-100-080		1°	8	45	4	☑
4RTE-010-100-100			10	45	4	☑
4RTE-010-100-120	12		45	4	☑	
4RTE-012-030-080	1,2	0°30'	8	45	4	☑
4RTE-012-030-100			10	45	4	☑
4RTE-012-030-120			12	45	4	☑
4RTE-012-030-160		0°45'	16	50	4	☑
4RTE-012-045-080			8	45	4	☑
4RTE-012-045-100			10	45	4	☑
4RTE-012-045-120	1°	12	45	4	☑	
4RTE-012-045-160		16	50	4	☑	
4RTE-012-100-080		8	45	4	☑	
4RTE-012-100-100	1,5	1°	10	45	4	☑
4RTE-012-100-120			12	45	4	☑
4RTE-012-100-160			16	50	4	☑
4RTE-015-030-060	1,5	0°30'	6	45	4	☑
4RTE-015-030-100			10	45	4	☑
4RTE-015-030-160			16	50	4	☑
4RTE-015-030-200		0°45'	20	60	4	☑
4RTE-015-100-060			6	45	4	☑
4RTE-015-100-100			10	45	4	☑
4RTE-015-100-160	1°	16	50	4	☑	
4RTE-015-100-200		20	60	4	☑	
4RTE-015-100-250		25	60	4	☑	
4RTE-015-130-060	2	1°30'	6	45	4	☑
4RTE-015-130-100			10	45	4	☑
4RTE-015-130-160			16	50	4	☑
4RTE-015-130-200		0°30'	20	60	4	☑
4RTE-015-130-250			25	60	4	☑
4RTE-020-030-100			10	45	4	☑
4RTE-020-030-160	1°	16	50	4	☑	
4RTE-020-030-200		20	60	4	☑	
4RTE-020-030-250		25	60	4	☑	
4RTE-020-100-100	10	45	4	☑		

Objednací číslo	D (mm)	Úhel θ	L1 (mm)	L (mm)	d h5 (mm)	Standardní položka
4RTE-020-100-160	2	1°	16	50	4	<input checked="" type="checkbox"/>
4RTE-020-100-200			20	60	4	<input checked="" type="checkbox"/>
4RTE-020-100-250			25	60	4	<input checked="" type="checkbox"/>
4RTE-020-130-100		1°30'	10	45	4	<input checked="" type="checkbox"/>
4RTE-020-130-160			16	50	4	<input checked="" type="checkbox"/>
4RTE-020-130-200			20	60	4	<input checked="" type="checkbox"/>
4RTE-020-130-250		25	60	4	<input checked="" type="checkbox"/>	
4RTE-025-030-100	2,5	0°30'	10	45	4	<input checked="" type="checkbox"/>
4RTE-025-030-160			16	50	4	<input checked="" type="checkbox"/>
4RTE-025-030-200			20	60	4	<input checked="" type="checkbox"/>
4RTE-025-030-250			25	60	4	<input checked="" type="checkbox"/>
4RTE-025-100-100		1°	10	45	4	<input checked="" type="checkbox"/>
4RTE-025-100-160			16	50	4	<input checked="" type="checkbox"/>
4RTE-025-100-200			20	60	4	<input checked="" type="checkbox"/>
4RTE-025-100-250			25	60	4	<input checked="" type="checkbox"/>
4RTE-025-130-100		1°30'	10	45	4	<input checked="" type="checkbox"/>
4RTE-025-130-160			16	50	4	<input checked="" type="checkbox"/>
4RTE-025-130-200			20	60	4	<input checked="" type="checkbox"/>
4RTE-025-130-250			25	60	4	<input checked="" type="checkbox"/>

4&6CTDB 4 a 6-břité soudečkové frézy pro tvarově složitě obrobky

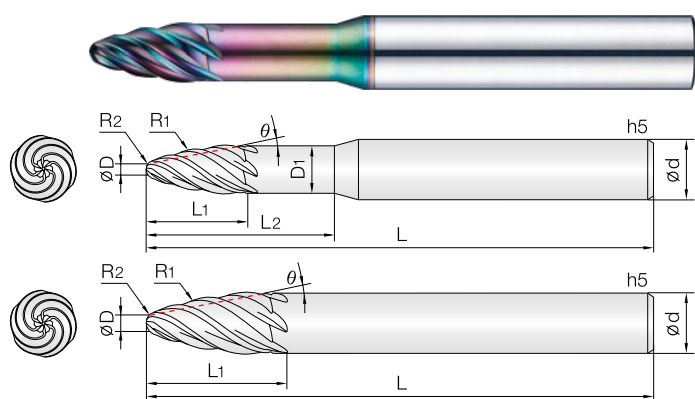

- Speciálně určeno pro tvarově složitě obrobky jako jsou rotory, lopatky turbín, kompresorová kola a profily pneumatik
- Vysoká produktivita obrábění díky vyššímu počtu břítů (4 a 6)
- Extrémní zrychlení dokončovacího obrábění díky vyššímu ap
- Možnost hrubování a dokončování jedním nástrojem

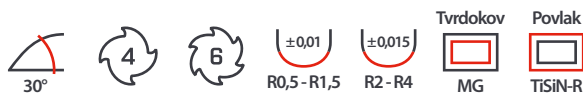

NOVINKA

Objednáací číslo	D (mm)	R1 (mm)	R2 (mm)	Úhel θ	D1 (mm)	L1 (mm)	L2 (mm)	L (mm)	d h5 (mm)	Standardní položka
4CTDB-010-013-047	1	13	0,5	10	2,4	4,7	10	50	4	<input checked="" type="checkbox"/>
4CTDB-015-020-071	1,5	20	0,75	10	3,6	7,1	15	50	4	<input checked="" type="checkbox"/>
4CTDB-020-025-094	2	25	1	10	4,8	9,4	20	60	6	<input checked="" type="checkbox"/>
4CTDB-020-350-116		350	1	15	7	11,6	18	80	8	<input checked="" type="checkbox"/>
4CTDB-030-040-141	3	40	1,5	10	7,3	14,1	30	80	8	<input checked="" type="checkbox"/>
6CTDB-040-050-187	4	50	2	10	9,5	18,7	40	100	12	<input checked="" type="checkbox"/>
6CTDB-040-750-124		750	2	30	-	12,4	-	110	16	<input checked="" type="checkbox"/>
6CTDB-060-075-200	6	75	3	10	-	20	-	100	12	<input checked="" type="checkbox"/>
6CTDB-060-1000-167		1000	3	20	-	16,7	-	110	16	<input checked="" type="checkbox"/>
6CTDB-080-100-268	8	100	4	5	-	26,8	-	110	12	<input checked="" type="checkbox"/>
6CTDB-080-1000-267		1000	4	10	-	26,7	-	110	16	<input checked="" type="checkbox"/>