

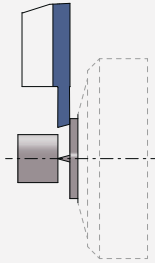

APPLITEC

261



251R

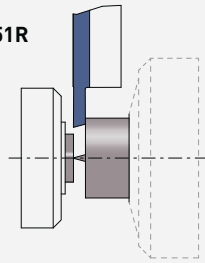

262

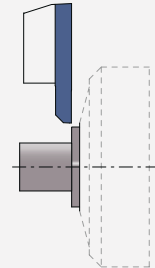

263

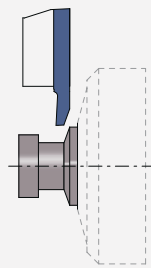

264

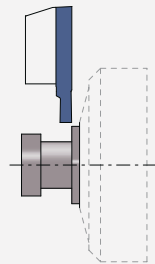

266

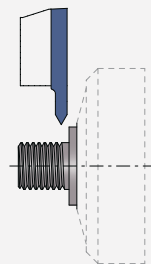

SORTY > **4.02**

STANDARDNÍ ŘEZNÉ PODMÍNKY **PŘÍSLUŠENSTVÍ** > **4.03**

DRŽÁKY > **4.04**



UPICHOVÁNÍ **Type 251 / 261** > **4.08**

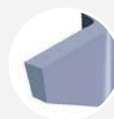

STRANOVÉ SOUSTRUŽENÍ **Type 252 / 262** > **4.10**

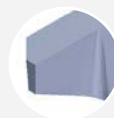

ZPĚTNÉ SOUSTRUŽENÍ **Type 253 / 263** > **4.11**



ZAPICHOVÁNÍ A SOUSTRUŽENÍ **Type 254 / 264** > **4.14**



SOUSTRUŽENÍ ZÁVITŮ **Type 256 / 266** > **4.16**



POLOTOVARY DESTIČEK **Type 251E / 261E** > **4.17**



SORTY

| | | |
|--|--|---|
| <p>AP302 μK20 + PVD povlak</p> | <p>AP202 μK20 + PVD povlak</p> | <p>N (μK20) nepovlakovaný</p> |
| <ul style="list-style-type: none"> • nejlepší univerzální sorta • první volba pro obrábění ocelí, nerezových ocelí a slitin titanu • velmi dobrá tepelná odolnost | <ul style="list-style-type: none"> • sorta vhodná zejména pro nízké řezné rychlosti | <ul style="list-style-type: none"> • vhodné pro přerušovaný řez a nestabilní podmínky obrábění |
| | | |

| | |
|---|---|
| <p>AH302 μK10 + PVD coating</p> | <p>HN (μK10) nepovlakovaný</p> |
| <ul style="list-style-type: none"> • sorta velmi odolná proti opotřebení • pro lehké obrábění ocelí, nerezových ocelí a titanu za stabilních podmínek | <ul style="list-style-type: none"> • mikrozmrný tvrdokov odolný proti opotřebení • vhodný pro obrábění nízkolegovaného titanu • není vhodné pro přerušovaný řez a nestabilní podmínky obrábění |
| | |
| | |

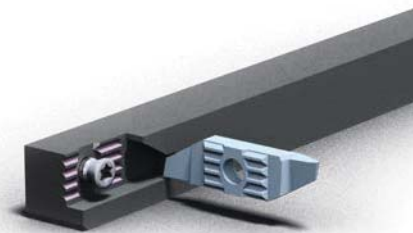



Patentovaný tuhý upínací systém

STANDARDNÍ ŘEZNÉ PODMÍNKY

| MATERIÁL | SOUSTRUŽENÍ | | UPICHOVÁNÍ | |
|--|---------------|------------------|---------------|------------------|
| | VC (m/min) | F (mm/otáčku) | VC (m/min) | F (mm/otáčku) |
| Automatové oceli (P) | 120 - 200 | 0.01 - 0.20 | 80 - 150 | 0.01 - 0.15 |
| Oceli < 600 N/mm ² (P) | 80 - 160 | 0.01 - 0.18 | 70 - 120 | 0.01 - 0.12 |
| Oceli < 800 N/mm ² (P) | 60 - 120 | 0.01 - 0.15 | 60 - 100 | 0.01 - 0.10 |
| Oceli > 800 N/mm ² (P) | 50 - 100 | 0.01 - 0.12 | 40 - 80 | 0.01 - 0.08 |
| Nerezové oceli (M) | 60 - 120 | 0.01 - 0.15 | 60 - 100 | 0.01 - 0.08 |
| Hliník (N) | 180 - 800 | 0.01 - 0.30 | 150 - 300 | 0.01 - 0.20 |
| Měď, mosaz, bronz (N) | 100 - 500 | 0.01 - 0.30 | 100 - 300 | 0.01 - 0.20 |
| Titan (S) | 30 - 70 | 0.01 - 0.12 | 30 - 50 | 0.01 - 0.06 |

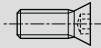
PŘÍSLUŠENSTVÍ

| Držáky |  |  | Další možnost Art. N° |
|-------------------|---|---|--------------------------|
| 250-8 / 260-8 | V-M3.5X7.3-T15 | C-T15 | SET-NM-TX15 |
| 250-... / 260-... | V-M4X9-T15 | | |
| 250RC / 260-C | V-M4X7.3-T15 | | |

Doporučení upínací moment

3.0 Nm



SET-NM-TX15

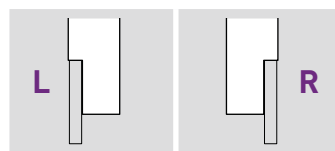
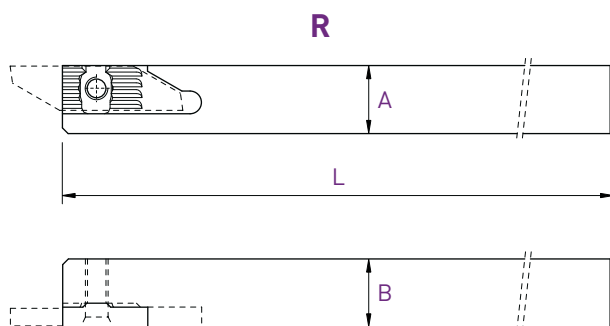

| A x B | L | Art. N° | Art. N° |
|-------------|-----|-----------|-----------|
| 8 x 8 | 115 | 250-8 | 260-8 |
| 10 x 10 | 115 | 250-10 | 260-10 |
| 12 x 12 | 130 | 250-12 | 260-12 |
| 12 x 12 | 90 | 250-12-90 | 260-12-90 |
| 12.7 x 12.7 | 130 | 250-12.7 | 260-12.7 |
| 16 x 16 | 130 | 250-16 | 260-16 |
| 16 x 16 | 75 | 250-16-75 | 260-16-75 |
| 20 x 20 | 120 | 250-20 | 260-20 |

Šroubky a klíč jsou součástí každého držáku

DRŽÁKY

260-C

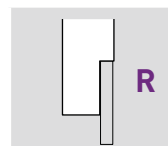
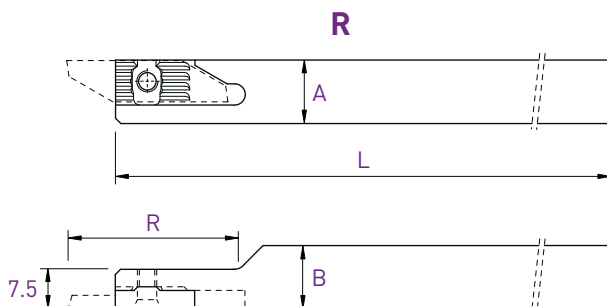
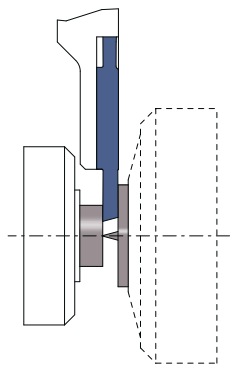

| A x B | L | R | Art. N° |
|---------|-----|----|----------|
| 12 x 12 | 130 | 30 | 260-C-12 |

DRŽÁKY

Upichování v pravé linii

250RC

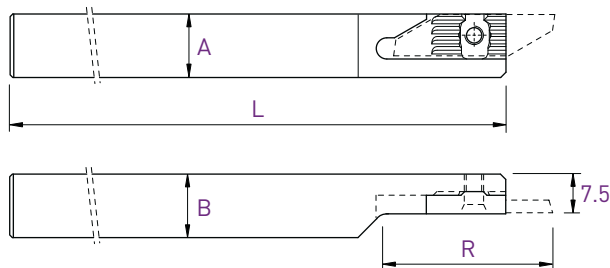
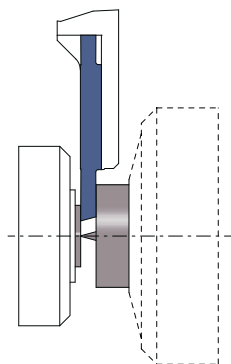

Pro destičky typu 251R

| A x B | L | R | Art. N° |
|---------|-----|----|----------|
| 12 x 12 | 130 | 30 | 250RC-12 |
| 16 x 16 | 130 | 40 | 250RC-16 |



Šroubky a klíč jsou součástí každého držáku

DRŽÁKY S VNITŘNÍM CHLAZENÍM

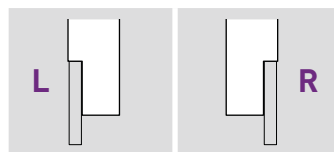
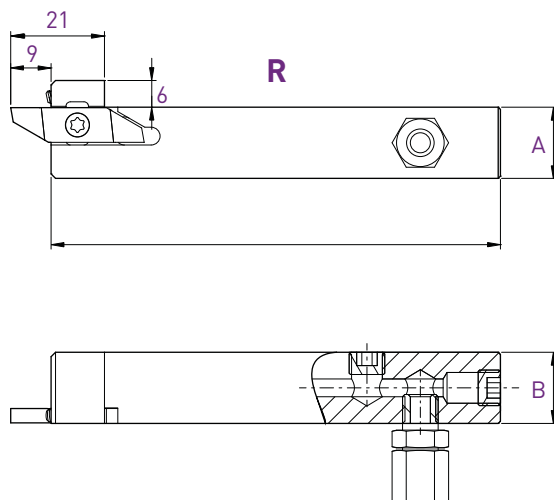
250-JET / 260-JET



| A x B | L | Art. N° | Art. N° |
|---------|-----|--------------|--------------|
| 10 x 12 | 100 | 250-1012-JET | 260-1012-JET |
| 12 x 12 | 100 | 250-12-JET | 260-12-JET |
| 16 x 16 | 100 | 250-16-JET | 260-16-JET |
| 20 x 20 | 100 | 250-20-JET | 260-20-JET |

| Náhradní díly |  |  | Tryska  |
|-------------------|---|---|---|
| | Art. N° | Art. N° | Art. N° |
| 250-JET / 260-JET | J-M8X1-D6 | JB-M8X1 | JJ-M3X6-D1.5 |

Šroubky a klíč jsou součástí každého držáku

DRŽÁKY

260/250F

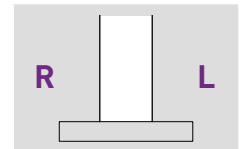
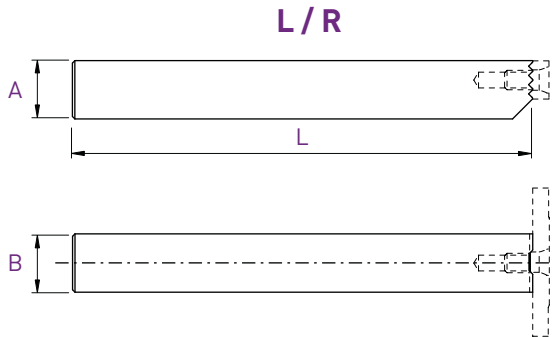

| A x B | L | Art. N° |
|---------|-----|----------------------|
| 10 x 12 | 120 | 260/250F-1012 |
| 12 x 12 | 120 | 260/250F-1212 |

DRŽÁKY

260/250-D

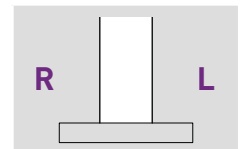
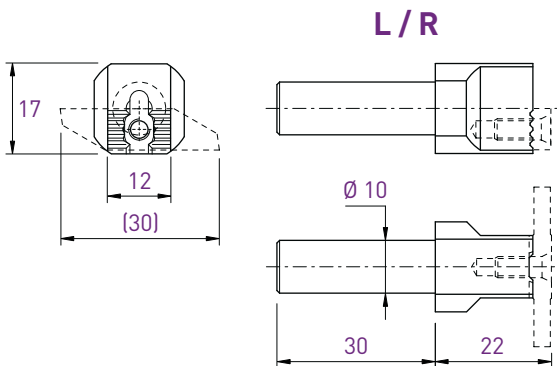

| Art. N° |
|--------------------|
| 260/250-D10 |

Šroubky a klíč jsou součástí každého držáku

UPICHOVÁNÍ

251 / 261

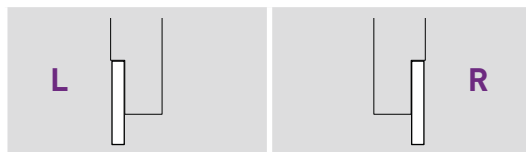
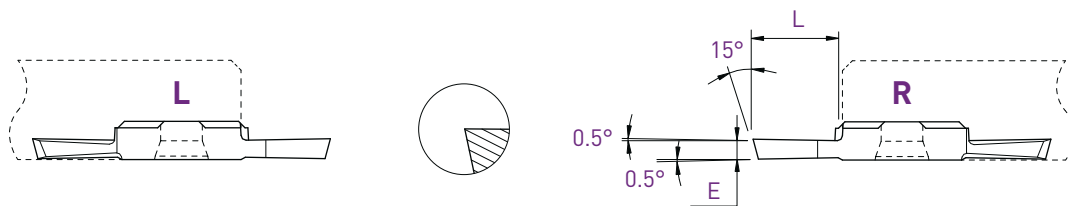

| E | L | Art. N° | AP302 | AP202 | Z | Art. N° | AP302 | AP202 | Z |
|-----|-----|---------|-------|-------|---|---------|-------|-------|---|
| 0.8 | 4 | 251-0.8 | ■ | □ | ■ | 261-0.8 | ■ | □ | ■ |
| 1.0 | 5 | 251-1.0 | ■ | □ | ■ | 261-1.0 | ■ | □ | ■ |
| 1.2 | 5 | 251-1.2 | ■ | □ | ■ | 261-1.2 | ■ | □ | ■ |
| 1.5 | 7 | 251-1.5 | ■ | □ | ■ | 261-1.5 | ■ | □ | ■ |
| 2.0 | 8.5 | 251-2.0 | ■ | □ | ■ | 261-2.0 | ■ | □ | ■ |
| 2.5 | 8.5 | 251-2.5 | ■ | □ | ■ | 261-2.5 | ■ | □ | ■ |

UPICHOVÁNÍ

UPICHOVÁNÍ V PRAVÉ LINII

261L / 251R

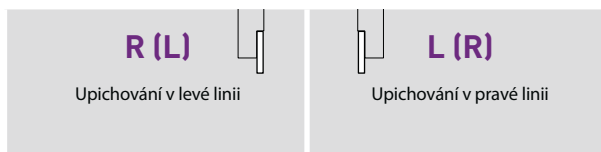
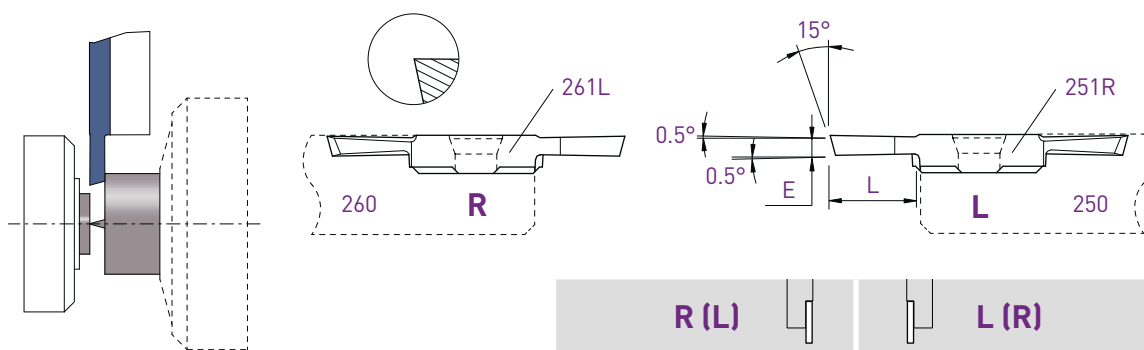

| E | L | Art. N° | AP302 | AP202 | Z | Art. N° | AP302 | AP202 | Z |
|-----|-----|----------|-------|-------|---|----------|-------|-------|---|
| 1.0 | 5 | - | | | | 251R-1.0 | ■ | □ | ■ |
| 1.5 | 7 | - | | | | 251R-1.5 | ■ | □ | ■ |
| 2.0 | 8.5 | 261L-2.0 | ■ | □ | ■ | 251R-2.0 | ■ | □ | ■ |

UPICHOVÁNÍ

251XF / 261XF

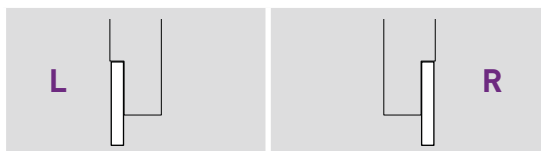
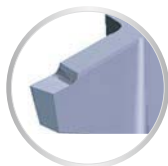
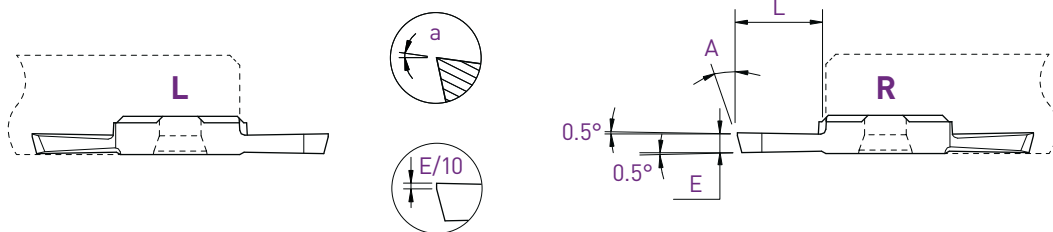

| a | E | L | A | Art. N° | AP302 | AP202 | Z | Art. N° | AP302 | AP202 | Z |
|----|-----|-----|-----|-----------|-------|-------|---|----------------|-------|-------|--------------|
| 4° | 1.0 | 4 | 15° | - | | | | 261XF-1.0 | ■ | ■ | ■ NEW |
| 6° | 1.0 | 4 | 8° | - | | | | 261XF6°-1.0-8° | ■ | ■ | ■ NEW |
| 4° | 1.5 | 7 | 15° | 251XF-1.5 | ■ | □ | ■ | 261XF-1.5 | ■ | □ | ■ |
| 4° | 2.0 | 8.5 | 15° | 251XF-2.0 | ■ | □ | ■ | 261XF-2.0 | ■ | □ | ■ |

UPICHOVÁNÍ

UPICHOVÁNÍ V PRAVÉ LINII

251RXF

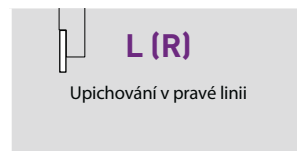
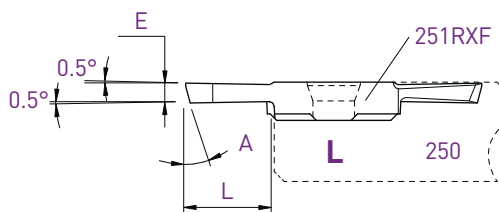
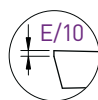
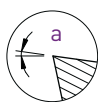
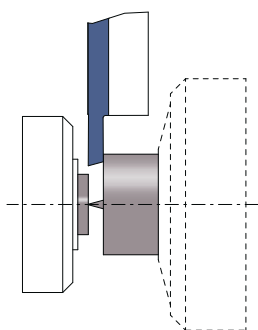

| a | E | L | A | Art. N° | AP302 | AP202 | Z |
|----|-----|-----|-----|-----------------|-------|-------|--------------|
| 6° | 1.0 | 4 | 8° | 251RXF6°-1.0-8° | ■ | ■ | ■ NEW |
| 4° | 1.5 | 7 | 15° | 251RXF-1.5 | ■ | □ | ■ |
| 4° | 2.0 | 8.5 | 15° | 251RXF-2.0 | ■ | □ | ■ |

■ = standardní položka
□ = nestandardní položka (závisí na momentální situaci na skladě)

STRANOVÉ SOUSTRUŽENÍ

252 / 262

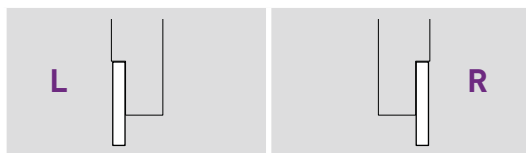

| A | Art. N° | AP302 | AP202 | Z | Art. N° | AP302 | AP202 | Z |
|----|---------|-------|-------|---|---------|-------|-------|---|
| 0° | 252 | ■ | □ | ■ | 262 | ■ | □ | ■ |
| 2° | 252-2° | ■ | □ | ■ | 262-2° | ■ | □ | ■ |

STRANOVÉ SOUSTRUŽENÍ

252X / 262X

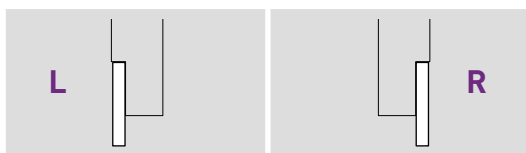
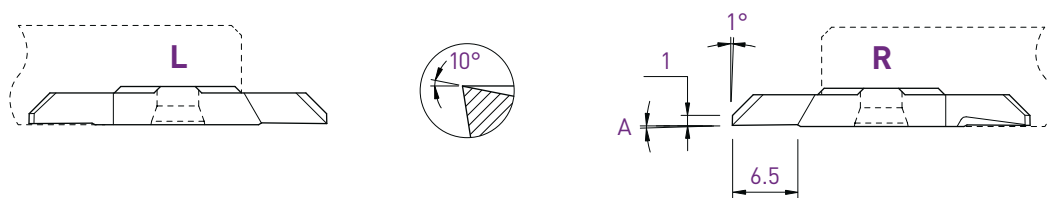

| A | Art. N° | AP302 | AP202 | Z | Art. N° | AP302 | AP202 | Z |
|----|---------|-------|-------|---|---------|-------|-------|---|
| 0° | 252X | ■ | □ | ■ | 262X | ■ | □ | ■ |
| 2° | 252X-2° | ■ | □ | ■ | 262X-2° | ■ | □ | ■ |

STRANOVÉ SOUSTRUŽENÍ

252S / 262S

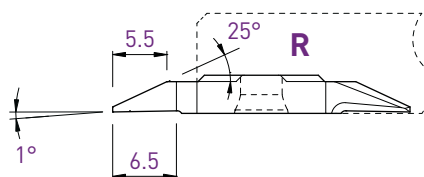
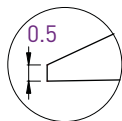
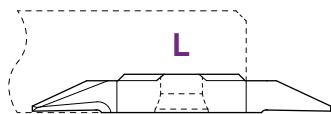

| L | | | | R | | | |
|---------|-------|-------|---|---------|-------|-------|---|
| Art. N° | AP302 | AP202 | Σ | Art. N° | AP302 | AP202 | Σ |
| 252S05 | ■ | □ | ■ | 262S05 | ■ | □ | ■ |

ZPĚTNÉ SOUSTRUŽENÍ

253S / 263S

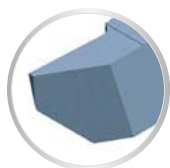
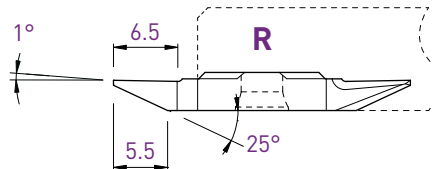
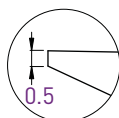
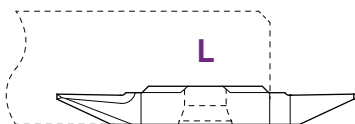

| L | | | | R | | | |
|---------|-------|-------|---|---------|-------|-------|---|
| Art. N° | AP302 | AP202 | Σ | Art. N° | AP302 | AP202 | Σ |
| 253S05 | ■ | □ | ■ | 263S05 | ■ | □ | ■ |

■ = standardní položka
□ = nestandardní položka (závisí na momentální situaci na skladě)

ZPĚTNÉ SOUSTRUŽENÍ

253 / 263

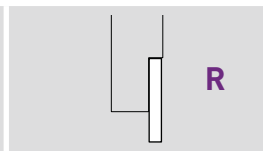
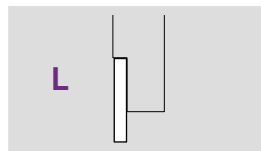
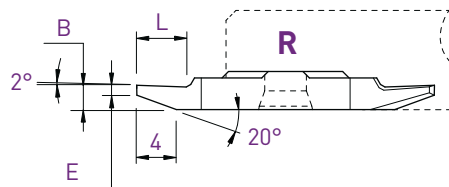
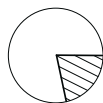
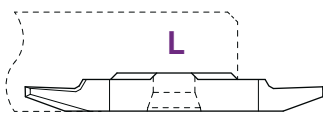

| B | E | L | Art. N° | AP302 | AP202 | Z | Art. N° | AP302 | AP202 | Z |
|-----|-----|---|---------|-------|-------|---|---------|-------|-------|---|
| 2.0 | 0.5 | 4 | 253-0.5 | ■ | □ | ■ | 263-0.5 | ■ | □ | ■ |
| 2.5 | 1.0 | 5 | 253-1.0 | ■ | □ | ■ | 263-1.0 | ■ | □ | ■ |

ZPĚTNÉ SOUSTRUŽENÍ

253X / 263X

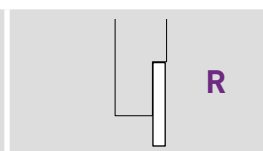
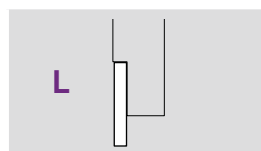
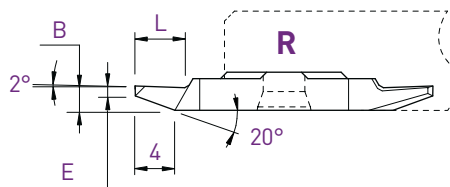
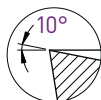
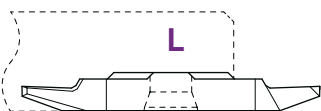

| B | E | L | Art. N° | AP302 | AP202 | Z | Art. N° | AP302 | AP202 | Z |
|-----|-----|---|----------|-------|-------|---|----------|-------|-------|---|
| 2.0 | 0.5 | 5 | 253X-0.5 | ■ | □ | ■ | 263X-0.5 | ■ | □ | ■ |
| 2.5 | 1.0 | 5 | 253X-1.0 | ■ | □ | ■ | 263X-1.0 | ■ | □ | ■ |

ZPĚTNÉ SOUSTRUŽENÍ

253VX-8° / 263VX-8°

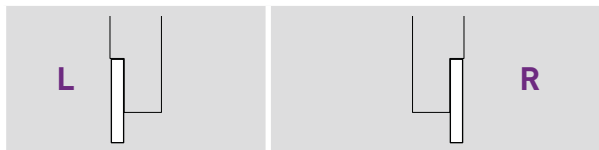
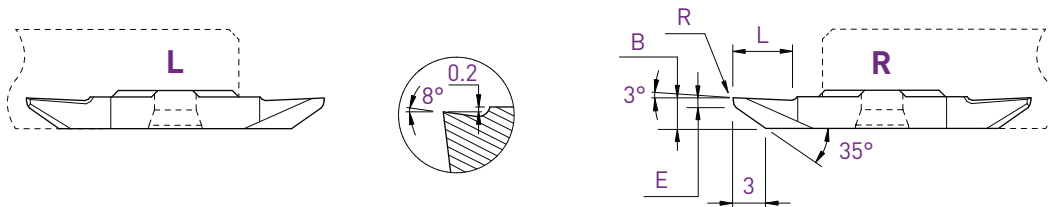

| B | E | L | R | Art. N° | AP302 | AP202 | Z | Art. N° | AP302 | AP202 | Z | AH302 | HN |
|-----|-----|---|------|----------|-------|-------|---|--------------|-------|-------|---|-------|----|
| 3.1 | 1.0 | 6 | 0 | 253VX-8° | ■ | □ | ■ | 263VX-8° | ■ | □ | ■ | | |
| 3.1 | 1.0 | 6 | 0.08 | - | | | | 263VX-8°-R08 | ■ | □ | ■ | ■ | ■ |
| 3.1 | 1.0 | 6 | 0.20 | - | | | | 263VX-8°-R20 | ■ | □ | ■ | ■ | ■ |

ZPĚTNÉ SOUSTRUŽENÍ

253VX-805 / 263VX-805

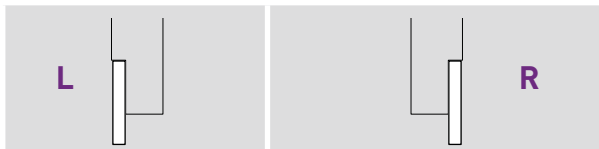
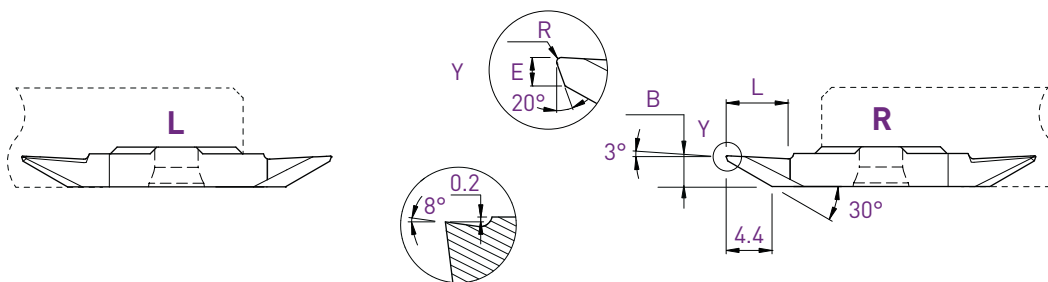

| B | E | L | R | Art. N° | AP302 | AP202 | Z | Art. N° | AP302 | AP202 | Z | AH302 | HN |
|-----|-----|---|------|---------------|-------|-------|---|---------------|-------|-------|---|-------|----|
| 3.0 | 0.5 | 6 | 0.08 | 253VX-805-R08 | ■ | □ | ■ | 263VX-805-R08 | ■ | □ | ■ | ■ | ■ |

■ = standardní položka
□ = nestandardní položka (závisí na momentální situaci na skladě)

ZAPICHOVÁNÍ A SOUSTRUŽENÍ

254 / 264

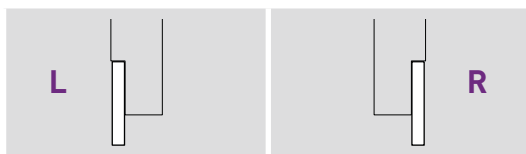
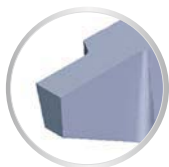
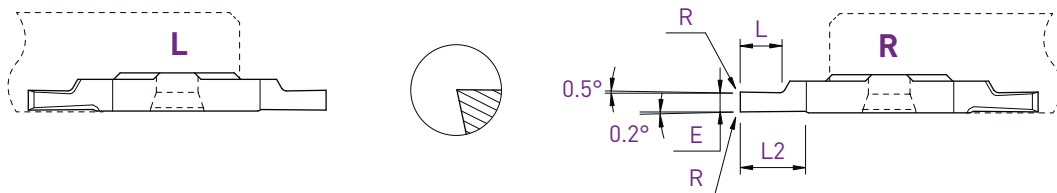

| E | L | L2 | R | Art. N° | AP302 | AP202 | Z | Art. N° | AP302 | AP202 | Z |
|-----|-----|-----|---|---------|-------|-------|---|---------|-------|-------|---|
| 0.8 | 2 | 4 | 0 | 254-0.8 | ■ | □ | ■ | 264-0.8 | ■ | □ | ■ |
| 1.0 | 2.5 | 4 | 0 | 254-1.0 | ■ | □ | ■ | 264-1.0 | ■ | □ | ■ |
| 1.2 | 3 | 4 | 0 | 254-1.2 | ■ | □ | ■ | 264-1.2 | ■ | □ | ■ |
| 1.5 | 3 | 4 | 0 | 254-1.5 | ■ | □ | ■ | 264-1.5 | ■ | □ | ■ |
| 1.8 | 4 | 6.5 | 0 | - | | | | 264-1.8 | ■ | □ | ■ |
| 2.0 | 4 | 6.5 | 0 | 254-2.0 | ■ | □ | ■ | 264-2.0 | ■ | □ | ■ |
| 2.5 | 6 | 6.5 | 0 | 254-2.5 | ■ | □ | ■ | 264-2.5 | ■ | □ | ■ |
| 3.0 | 6.5 | 6.5 | 0 | 254-3.0 | ■ | □ | ■ | 264-3.0 | ■ | □ | ■ |

ZAPICHOVÁNÍ A SOUSTRUŽENÍ

254X / 264X

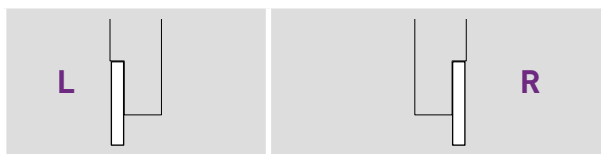
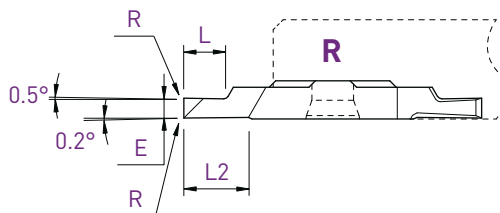
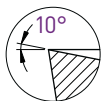
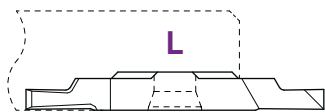

| E | L | L2 | R | Art. N° | AP302 | AP202 | Z | Art. N° | AP302 | AP202 | Z | AH302 | HN |
|-----|-----|-----|------|----------|-------|-------|---|--------------|-------|-------|---|-------|----|
| 0.8 | 2 | 4 | 0 | 254X-0.8 | ■ | □ | ■ | 264X-0.8 | ■ | □ | ■ | | |
| 1.0 | 2.5 | 4 | 0 | 254X-1.0 | ■ | □ | ■ | 264X-1.0 | ■ | □ | ■ | | |
| 1.0 | 2.5 | 4 | 0.08 | - | | | | 264X-1.0-R08 | ■ | □ | ■ | ■ | ■ |
| 1.2 | 3 | 4 | 0 | 254X-1.2 | ■ | □ | ■ | 264X-1.2 | ■ | □ | ■ | | |
| 1.5 | 3 | 4 | 0 | 254X-1.5 | ■ | □ | ■ | 264X-1.5 | ■ | □ | ■ | | |
| 1.5 | 3 | 4 | 0.08 | - | | | | 264X-1.5-R08 | ■ | □ | ■ | ■ | ■ |
| 1.5 | 3 | 4 | 0.20 | - | | | | 264X-1.5-R20 | ■ | □ | ■ | ■ | ■ |
| 2.0 | 4 | 6.5 | 0 | 254X-2.0 | ■ | □ | ■ | 264X-2.0 | ■ | □ | ■ | | |
| 2.0 | 4 | 6.5 | 0.08 | - | | | | 264X-2.0-R08 | ■ | □ | ■ | ■ | ■ |
| 2.0 | 4 | 6.5 | 0.20 | - | | | | 264X-2.0-R20 | ■ | □ | ■ | ■ | ■ |
| 2.5 | 6 | 6.5 | 0 | 254X-2.5 | ■ | □ | ■ | 264X-2.5 | ■ | □ | ■ | | |
| 2.5 | 6.5 | 6.5 | 0.08 | - | | | | 264X-2.5-R08 | ■ | □ | ■ | ■ | ■ |
| 2.5 | 6.5 | 6.5 | 0.20 | - | | | | 264X-2.5-R20 | ■ | □ | ■ | ■ | ■ |
| 3.0 | 6.5 | 6.5 | 0 | 254X-3.0 | ■ | □ | ■ | 264X-3.0 | ■ | □ | ■ | | |
| 3.0 | 6.5 | 6.5 | 0.08 | - | | | | 264X-3.0-R08 | ■ | □ | ■ | ■ | ■ |
| 3.0 | 6.5 | 6.5 | 0.20 | - | | | | 264X-3.0-R20 | ■ | □ | ■ | ■ | ■ |

■ = standardní položka

□ = nestandardní položka (závisí na momentální situaci na skladě)

SOUSTRUŽENÍ ZÁVITŮ

Částečný profil 60°

256-60 / 266-60

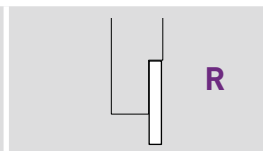
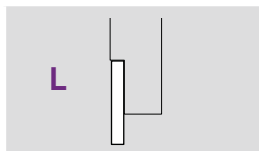
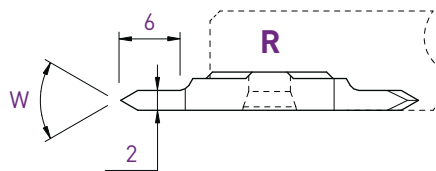
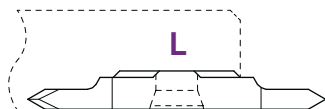

| W | R | a | Art. N° | AP302 | AP202 | Z | Art. N° | AP302 | AP202 | Z |
|-----|------|----|------------|-------|-------|---|------------|-------|-------|---|
| 60° | 0 | 0° | 256-60-2.0 | ■ | □ | ■ | 266-60-2.0 | ■ | □ | ■ |
| 60° | 0.06 | 3° | 256-AG60° | ■ | □ | ■ | 266-AG60° | ■ | □ | ■ |

SOUSTRUŽENÍ ZÁVITŮ

Částečný profil 55°

256-55 / 266-55

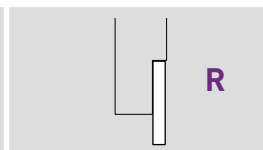
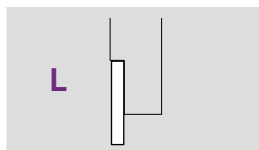
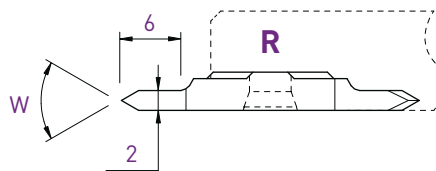
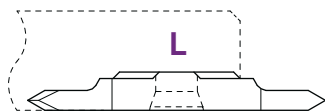

| W | R | a | Art. N° | AP302 | AP202 | Z | Art. N° | AP302 | AP202 | Z |
|-----|------|----|------------|-------|-------|---|------------|-------|-------|---|
| 55° | 0 | 0° | 256-55-2.0 | ■ | □ | ■ | 266-55-2.0 | ■ | □ | ■ |
| 55° | 0.06 | 3° | 256-AG55° | ■ | □ | ■ | 266-AG55° | ■ | □ | ■ |

POLOTOVARY DESTIČEK

251-E / 261-E

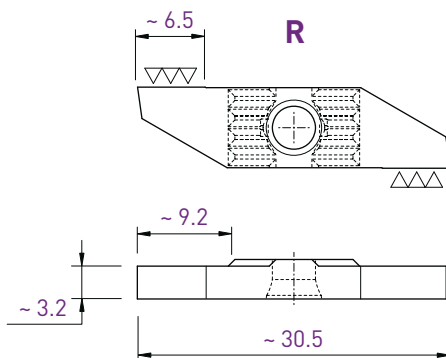
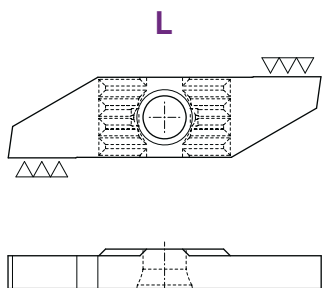

| L | | | | | R | | | | | | |
|---------|-------|-------|---|-------|----|---------|-------|-------|---|-------|----|
| Art. N° | AP302 | AP202 | N | AH302 | HN | Art. N° | AP302 | AP202 | N | AH302 | HN |
| 251-E | ■ | □ | ■ | ■ | ■ | 261-E | ■ | □ | ■ | ■ | ■ |

■ = standardní položka
 □ = nestandardní položka (závisí na momentální situaci na skladě)