







## DOPORUČENÉ POUŽITÍ PRO UPICHOVÁNÍ

700 série

ŘEZNÁ GEOMETRIE	AUTOMATOVÉ OCELI	OCELI	NEREZOVÉ OCELI	HLINÍK	TITAN	MOSAZ, BRONZ	MĚĎ	★	PRVNÍ VOLBA
								☆	DOPORUČENO
								☑	PRO KŘEHKÉ A VELMI MALÉ OBROBKY
 0°	★	☑	☑	☑	☑	★	☑	Velmi snadné přebušování	
 X4°	★	★	★	☑	☑		☑	Snížení řezné síly, přebušování možné	
 XF	☆	★	★				☆	Pro obtížné materiály (zesílená špička)	
 X12°			☆	★	★		★	Velmi dobré utváření třísky	
 X25°			☆	★	☆		☆	Pro lepivé materiály s dlouhou třískou	
 U	☆	☆	☆					Pro zúžení třísky, snadné přebušování	
 ZU8	★	★	★	☆ <5% Si	☆	☆		Velmi dobré utváření třísky (honované ostří) f: min 0,02 mm/ot.	

## UPICHOVÁNÍ

731 / 741

L

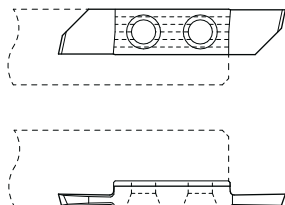

R

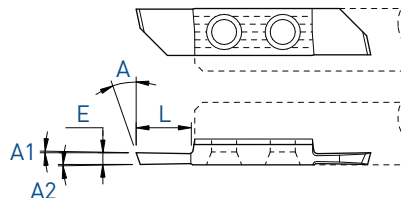

L



R



E	A	A1	A2	L	Art. N°	TiAlN	TiN	N (μk20)	HTA	HTiN	HN (μk10)	Art. N°	TiAlN	TiAlX	TiN	N (μk20)	HTA	HTiN	HN (μk10)		
0.6	18°	2.5°	0.5°	3	731-0.6	■	■	■	■	■	■	741-0.6	■	■	■	■	■	■	■	■	
0.8	20°	0.3°	0.3°	5	731-0.8	■	■	■	■	□	■	741-0.8	■	■	■	■	■	■	■	■	
1.0	20°	0.3°	0.3°	5	731-1.0	■	■	■	■	■	■	741-1.0	■	■	■	■	■	■	■	■	
1.2	20°	0.3°	0.3°	5	731-1.2	■	■	■	■	□	■	741-1.2	■	■	■	■	■	■	■	■	
1.5	20°	0.3°	0.3°	7	731-1.5	■	■	■	■	■	■	741-1.5	■	■	■	■	■	■	■	■	
1.8	20°	0.3°	0.3°	7	731-1.8	■	■	■	■	□	■	741-1.8	■	■	■	■	■	■	□	■	
2.0	20°	0.3°	0.3°	7	731-2.0	■	■	■	■	□	■	741-2.0	■	■	■	■	■	■	■	■	■
2.5	20°	0.3°	0.3°	7	731-2.5	■	■	■	■	■	■	741-2.5	■	■	■	■	■	■	■	□	■

7XX-XX-B



Destičky se způsobem upínání (B) na vyžádání  
Více informací naleznete na stránce 1.03

**UPICHOVÁNÍ**

**731X4 / 741X4**

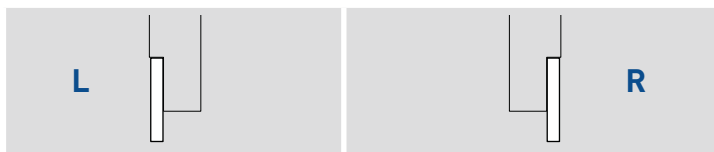
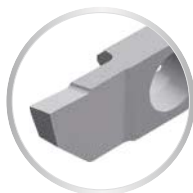
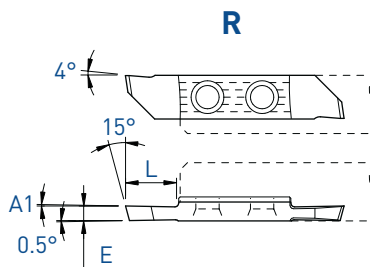
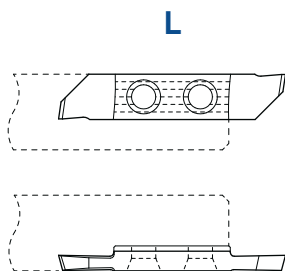

E	A1	L	Art. N°	L			R			Art. N°	R			HTA	HTIN	HN [μk10]
				TiAlN	TiN	N [μk20]	TiAlN	TiAlX	TiN		N [μk20]					
0.6	2.5°	3	731X4-0.6	■		■	■			741X4-0.6	■	■	■	■		■
0.8	0.5°	4	-							741X4-0.8					■	■
1.0	0.5°	5	731X4-1.0	■	■	■				741X4-1.0	■	■	■	■	□	■
1.5	0.5°	7	731X4-1.5	■	■	■	■	□	■	741X4-1.5	■	■	■	■	□	■
2.0	0.5°	7	731X4-2.0	■	■	■				741X4-2.0	■	■	■	■		

**7XX-XX-B**



Destičky se způsobem upínání (B) na vyžádání  
Více informací naleznete na stránce 1.03

■ = standardní položka  
□ = nestandardní položka (závisí na momentální situaci na skladě)

UPICHOVÁNÍ

731XF / 741XF

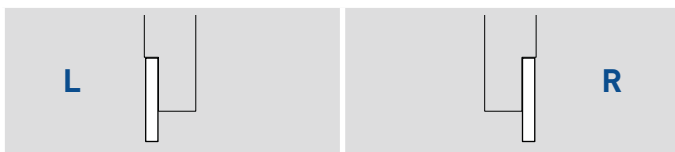
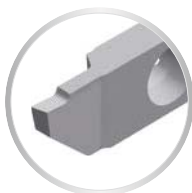
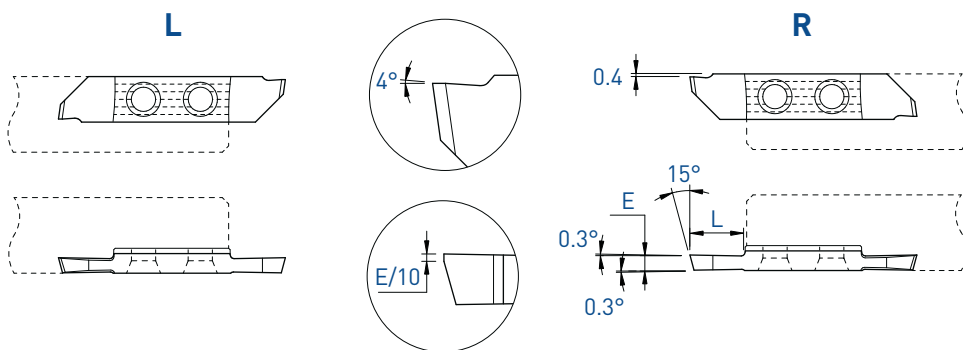

E	L	Art. N°	L			R									
			TiAlN	TiN	N (μk20)	HTA	HTiN	HN (μk10)	Art. N°	TiAlN	TiN	N (μk20)	HTA	HTiN	HN (μk10)
1.2	5	-							741XF-1.2	■	□	■			
1.5	7	731XF-1.5	■	■	■	■	■	■	741XF-1.5	■	■	■	■	■	■
2.0	7	731XF-2.0	■	■	■				741XF-2.0	■	■	■	■	■	■
2.5	7	731XF-2.5	■	■	■				741XF-2.5	■	■	■			

7XX-XX-B



Destičky se způsobem upínání (B) na vyžádání  
Více informací naleznete na stránce 1.03

**UPICHOVÁNÍ**

**731X12 / 741X12**

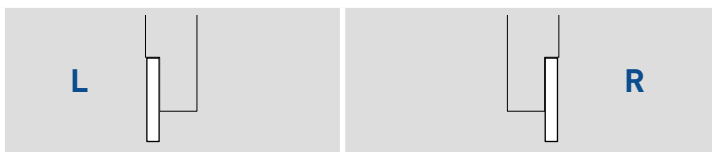
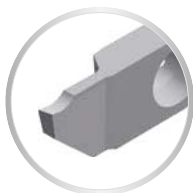
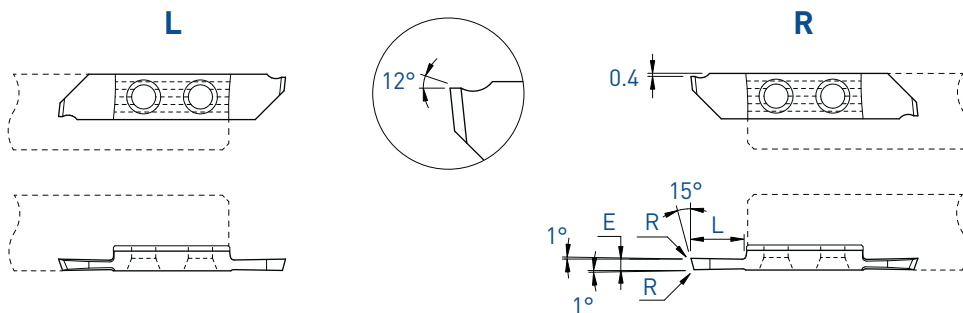

E	L	R	Art. N°	TiAlN	TiN	N (µk20)	HTA	HTiN	HN (µk10)	Art. N°	TiAlN	TiAlX	TiN	N (µk20)	HTA	HTiN	HN (µk10)
0.5	3	0.03	-							741X12-0.5					■		■
1.0	5	0.03	731X12-1.0	■	■	■				741X12-1.0	■	■	■	■	■	□	■
1.5	7	0.03	731X12-1.5	■	■	■				741X12-1.5	■	■	■	■	■	■	■
2.0	7	0.03	731X12-2.0	■	■	■				741X12-2.0	■	■	■	■	■	□	■

**7XX-XX-B**



Destičky se způsobem upínání (B) na vyžádání  
Více informací naleznete na stránce 1.03

■ = standardní položka  
□ = nestandardní položka (závisí na momentální situaci na skladě)

UPICHOVÁNÍ

731X25 / 741X25

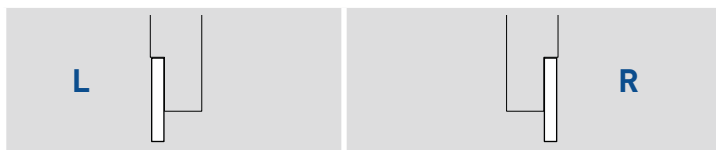
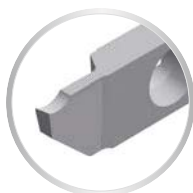
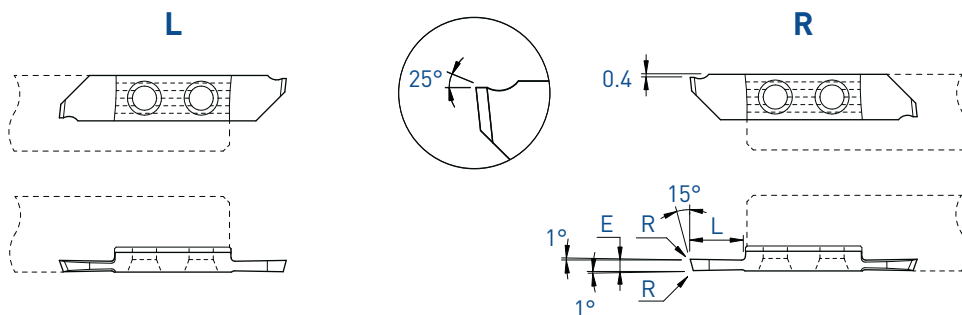

E	L	Art. N°	L			R			Art. N°	R							
			TiAlN	TiN	N (µk20)	HTA	HTiN	HN (µk10)		TiAlN	TiAlX	TiN	N (µk20)	HTA	HTiN	HN (µk10)	
1.0	5	731X25-1.0	■	■	■				741X25-1.0	■		■	■	■	■	□	■
1.5	7	731X25-1.5	■	■	■				741X25-1.5	■		■	■	■	■	□	■
2.0	7	731X25-2.0	■	■	■				741X25-2.0	■	■	■	■	■	■	□	■

7XX-XX-B



Destičky se způsobem upínání (B) na vyžádání  
Více informací naleznete na stránce 1.03

**UPICHOVÁNÍ**

**731U / 741U**

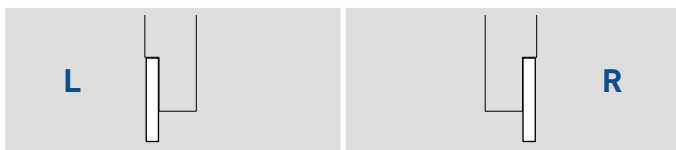
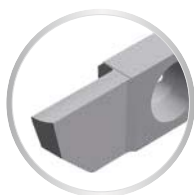
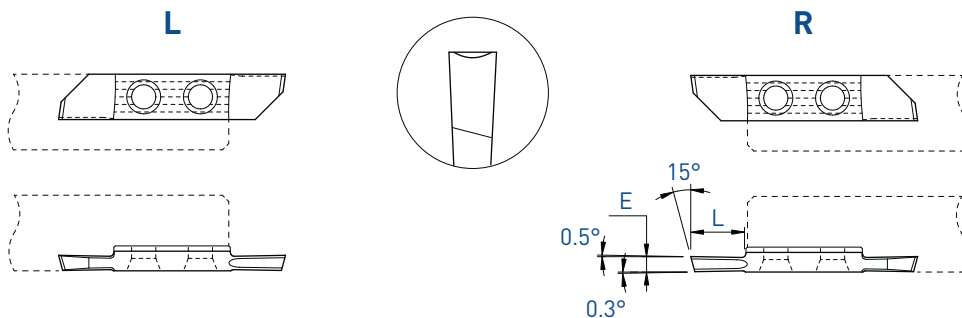

E	L	Art. N°	L			R									
			TiAlN	TiN	N (µk20)	HTA	HTiN	HN (µk10)	Art. N°	TiAlN	TiN	N (µk20)	HTA	HTiN	HN (µk10)
1.5	7	731U-1.5	■	■	■	■	□	■	741U-1.5	■	■	■	■	■	■
2.0	7	731U-2.0	■	■	■	■	□	■	741U-2.0	■	■	■	■	□	■

■ = standardní položka  
□ = nestandardní položka (závisí na momentální situaci na skladě)

## UPICHOVÁNÍ

731N / 741N

L

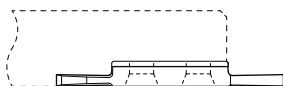
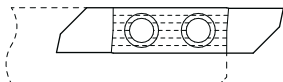

R

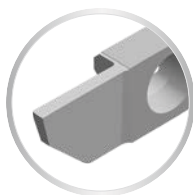
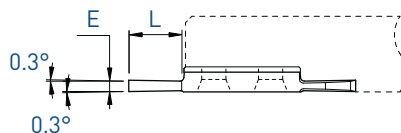
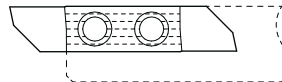

L

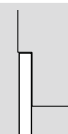

R



E	L	Art. N°	TiAlN	TiN	N (μm20)	HTA	HTiN	HN (μm10)	Art. N°	TiAlN	TiN	N (μm20)	HTA	HTiN	HN (μm10)
1.0	5	731N-1.0	■	■	■	■	□	■	741N-1.0	■	■	■	■	□	■
1.5	7	731N-1.5	■	■	■	■	□	■	741N-1.5	■	■	■	■	□	■

7XX-XX-B



Destičky se způsobem upínání (B) na vyžádání  
Více informací naleznete na stránce 1.03



**Cut L**

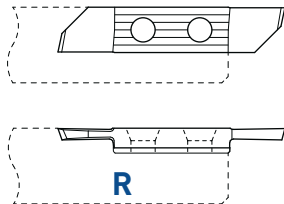

**Cut R**

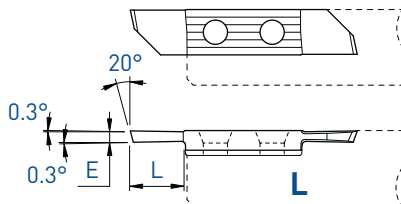

**R (L)**

LEVÁ upichovací linie

**L (R)**

PRAVÁ upichovací linie

E	L	Art. N°	TiAlN	TiN	N (µk20)	HTA	HTiN	HN (µk10)	Art. N°	TiAlN	TiN	N (µk20)	HTA	HTiN	HN (µk10)
1.0	5	741L-1.0	■	■	■	■	□	■	731R-1.0	■	■	■	■	■	■
1.2	5	741L-1.2	■	■	■	■	□	■	731R-1.2	■	■	■	■	□	■
1.5	7	741L-1.5	■	■	■	■	■	■	731R-1.5	■	■	■	■	■	■
2.0	7	741L-2.0	■	■	■	■	□	■	731R-2.0	■	■	■	■	□	■
2.5	7	741L-2.5	■	■	■				731R-2.5	■	■	■			

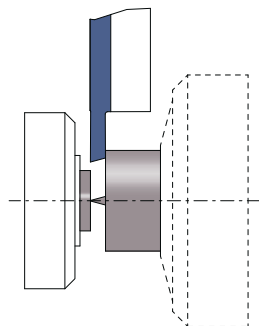

UPICHOVÁNÍ

UPICHOVÁNÍ V OPAČNÉ LINII

741LX4 / 731RX4

Cut L

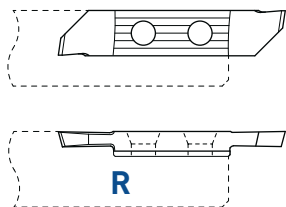

Cut R

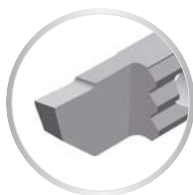
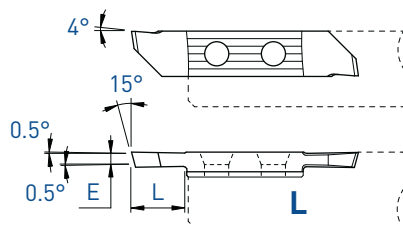

R (L)

LEVÁ upichovací linie

L (R)

PRAVÁ upichovací linie

E	L	Art. N°	TiAIN	TiN	N (µk20)	HTA	HTiN	HN (µk10)	Art. N°	TiAIN	TiN	N (µk20)	HTA	HTiN	HN (µk10)
1.5	5	741LX4-1.5	■	■	■				731RX4-1.5	■	■	■	■	■	■

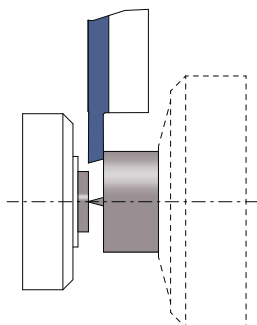

**UPICHOVÁNÍ**

**UPICHOVÁNÍ V OPAČNÉ LINII**

**741LXF / 731RXF**

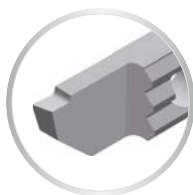
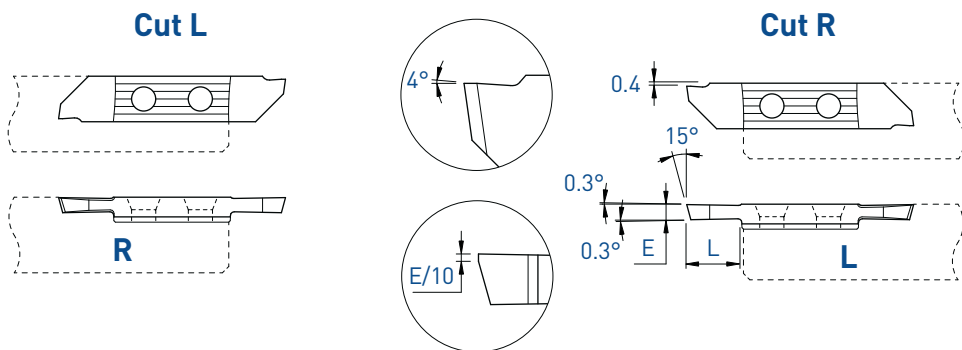

<b>R (L)</b>		<b>L (R)</b>	
LEVÁ upichovací linie		PRAVÁ upichovací linie	

E	L	Art. N°	TiAIN	TiN	N (µk20)	HTA	HTiN	HN (µk10)	Art. N°	TiAIN	TiN	N (µk20)	HTA	HTiN	HN (µk10)
1.5	7	741LXF-1.5	■	■	■				731RXF-1.5	■	■	■	■	■	■
2.0	7	741LXF-2.0	■	■	■				731RXF-2.0	■	■	■	■	□	■
2.5	7	741LXF-2.5	■	■	■				731RXF-2.5	■	■	■	■		

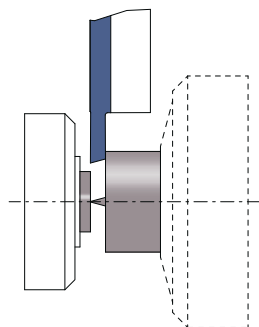

■ = standardní položka  
 □ = nestandardní položka (závisí na momentální situaci na skladě)

UPICHOVÁNÍ

UPICHOVÁNÍ V OPAČNÉ LINII

741LX12 / 731RX12

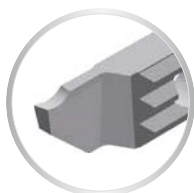
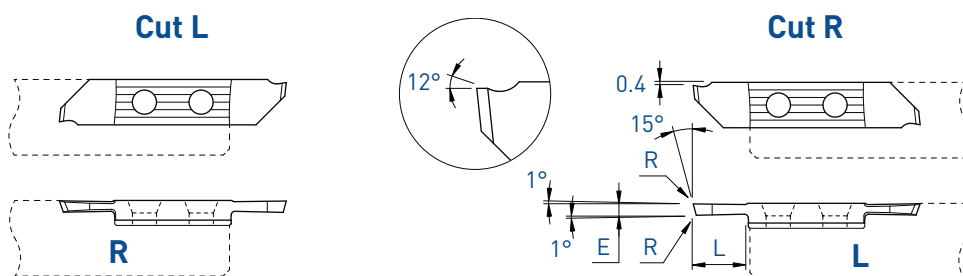

<b>R (L)</b>	<b>L (R)</b>
LEVÁ upichovací linie	PRAVÁ upichovací linie

E	L	R	Art. N°	TiAlN	TiN	N (µk20)	HTA	HTiN	HN (µk10)	Art. N°	TiAlN	TiN	N (µk20)	HTA	HTiN	HN (µk10)
1.0	5	0.03	-							731RX12-1.0	■	□	■			
1.5	7	0.03	741LX12-1.5	■	■	■				731RX12-1.5	■	■	■	■	■	■

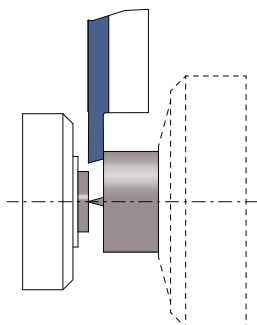

**UPICHOVÁNÍ**

**UPICHOVÁNÍ V OPAČNÉ LINII**

**741LX25 / 731RX25**

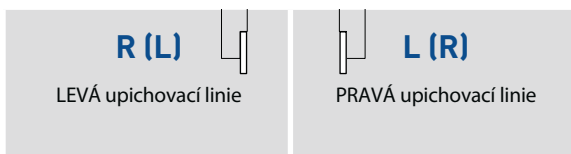
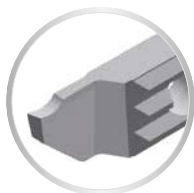
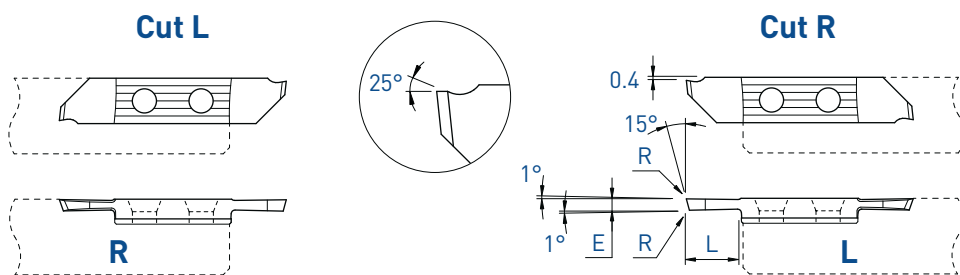

E	L	R	Art. N°	TiAIN	TiN	N (µk20)	Art. N°	TiAIN	TiN	N (µk20)
1.5	7	0.03	741LX25-1.5	■	■	■	731RX25-1.5	■	■	■

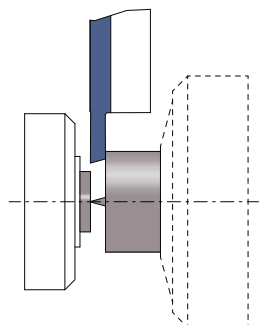

■ = standardní položka  
 □ = nestandardní položka (závisí na momentální situaci na skladě)

## Cut R

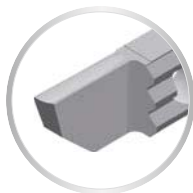
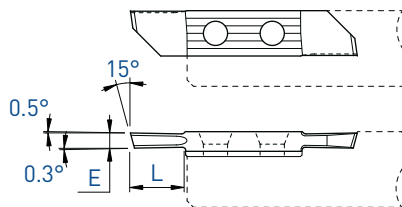
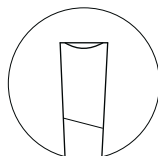

## L (R)

PRAVÁ upichovací linie

E	L	Art. N°	TiAlN	TiN	N (μk20)	HTA	HTiN	HN (μk10)
1.0	5	731RU-1.0	■	□	■			
1.2	5	731RU-1.2	■	□	■			
1.5	7	731RU-1.5	■	□	■	■	□	■
2.0	7	731RU-2.0	■	□	■			

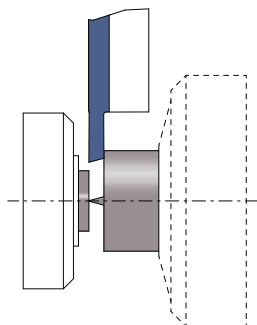

**UPICHOVÁNÍ**

**UPICHOVÁNÍ V OPAČNÉ LINII**

**741N / 731N**

**Cut L**

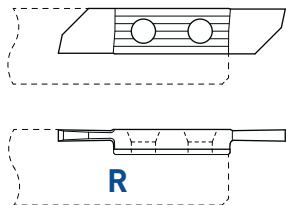

**Cut R**

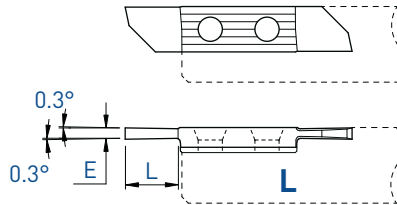

**R (L)**

LEVÁ upichovací linie

**L (R)**

PRAVÁ upichovací linie

E	L	Art. N°	TiAIN	TiN	N (µk20)	HTA	HTiN	HN (µk10)	Art. N°	TiAIN	TiN	N (µk20)	HTA	HTiN	HN (µk10)
1.0	5	<b>741N-1.0</b>	■	■	■	■	□	■	<b>731N-1.0</b>	■	■	■	■	□	■
1.5	7	<b>741N-1.5</b>	■	■	■	■	□	■	<b>731N-1.5</b>	■	■	■	■	□	■

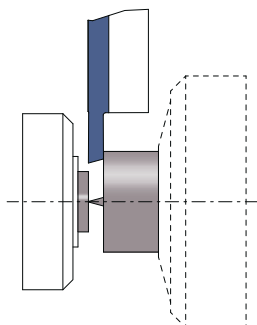

■ = standardní položka  
□ = nestandardní položka (závisí na momentální situaci na skladě)

L

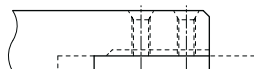
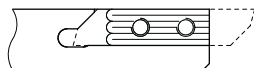

R

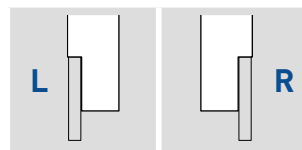
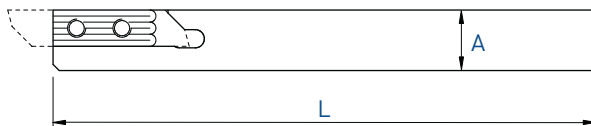

STANDARDNÍ ZPŮSOB  
UPÍNÁNÍ (A)

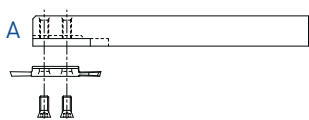

ZPŮSOB UPÍNÁNÍ (B)

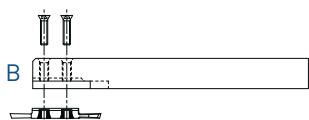

A x B	L	TYP UPÍNÁNÍ	Art. N°	Art. N°
7 x 7	115	A	730-7	740-7
8 x 8	115	A + B	730-8	740-8
8 x 8	140	A + B	730-8-140	-
10 x 10	115	A + B	730-10	740-10
10 x 10	50	A + B	730-10-50	740-10-50
12 x 12	130	A + B	730-12	740-12
12 x 12	90	A + B	730-12-90	740-12-90
12.7 x 12.7	130	A + B	730-12.7	740-12.7
16 x 16	130	A + B	730-16	740-16
16 x 16	75	A + B	730-16-75	740-16-75
20 x 20	120	A + B	730-20	740-20



Šroubky a klíče jsou součástí každého držáku



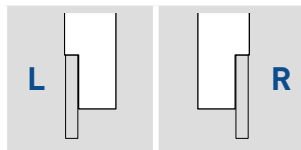
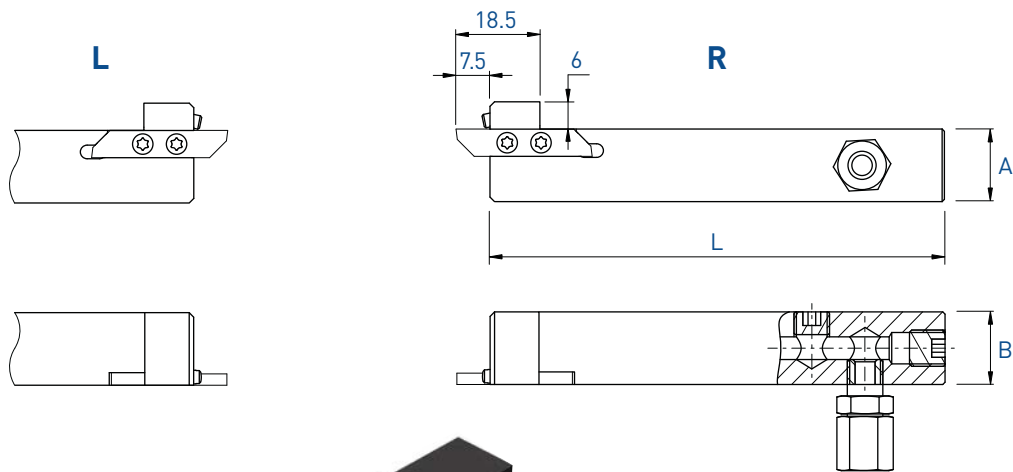

**DRŽÁKY S VNITŘNÍM CHLAZENÍM**

**730-JET / 740-JET**



A x B	L	TYP UPÍNÁNÍ	Art. N°	Art. N°
8 x 10	100	A + B	-	740-0810-JET
10 x 12	100	A + B	730-1012-JET	740-1012-JET
12 x 12	100	A + B	730-12-JET	740-12-JET
12.7 x 12.7	100	A + B	730-12.7-JET	740-12.7-JET
16 x 16	100	A + B	730-16-JET	740-16-JET
20 x 20	100	A + B	730-20-JET	740-20-JET

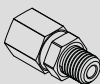

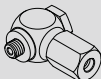
NÁHRADNÍ DÍLY			TRYSKA 	VOLITELNÉ 
	Art. N°	Art. N°	Art. N°	Art. N°
740-0810-JET	J-M5-D5	JB-M5	-	JC-M5-D5
730-JET / 740-JET	J-M8X1-D6	JB-M8X1	JJ-M3X6-D1.5	-

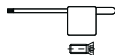

Šroubky a klíč jsou součástí každého držáku

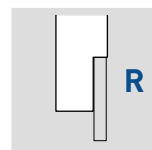
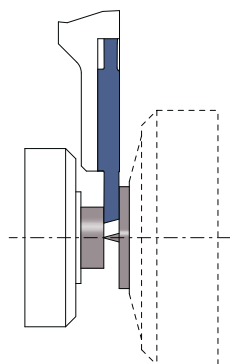
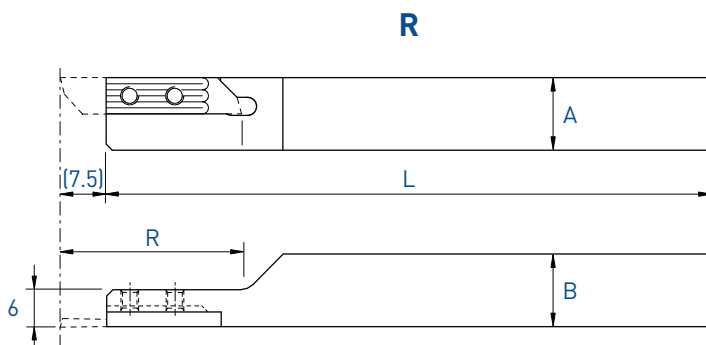

A x B	L	R	TYP UPÍNÁNÍ	Art. N°
8 x 8	115	24	A	<b>740-C-8</b>
10 x 10	115	24	A	<b>740-C-10</b>
12 x 12	130	30	A	<b>740-C-12</b>
16 x 16	130	40	A	<b>740-C-16</b>

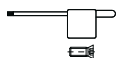

Šroubky a klíč jsou součástí každého držáku

Pro destičky typu 731R  
(stránky 1.39 - 1.45)

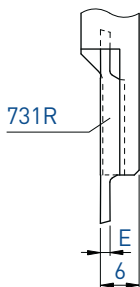
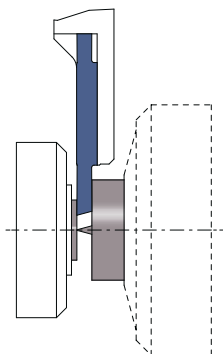
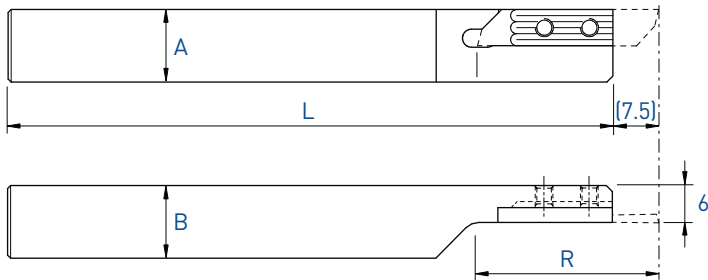

L (R) UPICHOVÁNÍ V PRAVÉ LINII			
A x B	L	R	Art. N°
8 x 8	115	24	<b>730RC-8</b>
10 x 10	115	24	<b>730RC-10</b>
12 x 12	130	30	<b>730RC-12</b>
16 x 16	130	40	<b>730RC-16</b>

TYP UPÍNÁNÍ: A

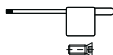

Šroubky a klíč jsou součástí každého držáku

## ANTIVIBRAČNÍ DRŽÁKY

730-NOVIBRA  
740-NOVIBRA

L

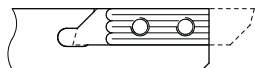

R

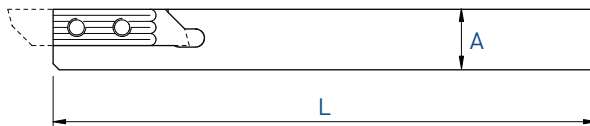

L



R



A x B	L	TYP UPÍNÁNÍ	Art. N°	Art. N°
7 x 7	115	A	730-7-NOVIBRA	740-7-NOVIBRA
8 x 8	115	A + B	730-8-NOVIBRA	740-8-NOVIBRA
8 x 8	80	A + B	-	740-8-80-NOVIBRA
10 x 10	115	A + B	-	740-10-NOVIBRA
12 x 12	130	A + B	-	740-12-NOVIBRA



Šroubky a klíč jsou součástí každého držáku

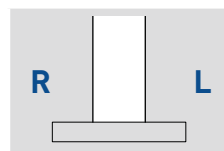
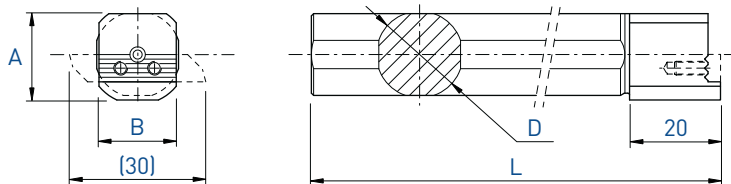

D	L	A	B	Art. N°
16	160	19	17	<b>740/730-D16</b>
19.05	160	19	17	<b>740/730-D19.05</b>
19.05	110	19	17	<b>740/730-D19.05-S</b>
20	160	19.5	17	<b>740/730-D20</b>
22	110	20	17	<b>740/730-D22</b>
25	200	22	17	<b>740/730-D25</b>
25.4	200	22	17	<b>740/730-D25.4</b>

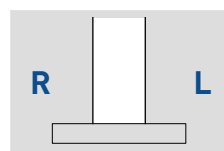
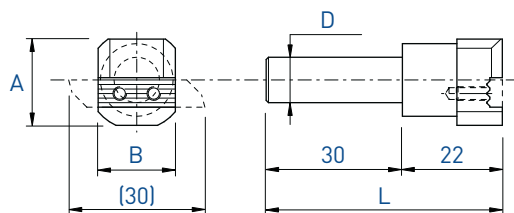



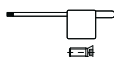





D	L	A	B	Art. N°
10	52	19	17	<b>740/730-D10</b>



Šroubky a klíč jsou součástí každého držáku

## NÁHRADNÍ DÍLY

	DRŽÁKY	STANDARDNÍ ZPŮSOB UPÍNÁNÍ (A)		ZPŮSOB UPÍNÁNÍ (B)	
					
710	710-6 / - NOVIBRA	V-M2.5X5.8-T8	C-T8	-	-
	710-7 / - NOVIBRA	V-M2.5X6.5-T8			
	710-8 / - NOVIBRA	V-M2.5X7.8-T8			
	710-10 - 710-12				
720	720-7	V-M2.5X6.5-T8	C-T8	-	-
	720-8 - 720-12	V-M2.5X7.8-T8			
730	730-7 / - JET / -NOVIBRA	V-M3X7-T8	C-T8	-	-
	730-8 / -NOVIBRA			V-M2.5X7.8-T8	C-T8
	730-10 - 730-20				
	730-DECO10				
	730R-DECO10				
730RC	V-M3X5.5-T8				
740	740-7 / -JET / -NOVIBRA	V-M3X7-T8	C-T8	-	-
	740-8 / -NOVIBRA - 740-12 / -NOVIBRA			V-M2.5X7.8-T8	C-T8
	740-16 - 740-20				
	740/730-D				
	740-C			V-M3X5.5-T8	
	740-DECO10			V-M3X7-T8	
	740L-DECO10			V-M3X9-T8	
740-Z					
	DRŽÁKY	STANDARDNÍ ZPŮSOB UPÍNÁNÍ (A)		ZPŮSOB UPÍNÁNÍ (B)	
					
750	750-10 - 750-12 / -JET	V-M4X9-T15	C-T15	-	-
	750-10-AB			V-M3X10-BN21	C-6P-2.0
	750-12-AB			V-M3X8-BN11	
	750-12.7 - 750-14			V-M3X10-BN11	C-6P-2.5
	750-16			V-M3X12-BN11	
	750-20			V-M3X16-BN11	
	750RAS - 750-RC			V-M4X7.3-T15	
750R-DECO10	V-M4X5.6-T15				
760	760-10 - 760-12 / -JET / -NOVIBRA / 760/750	V-M4X9-T15	C-T15	-	-
	760-10-AB			V-M3X10-BN21	C-6P-2.0
	760-12-AB			V-M3X8-BN11	
	760-12.7 - 760-14			V-M3X10-BN11	C-6P-2.5
	760-16			V-M3X12-BN11	
	760-20			V-M3X16-BN11	
	760LC			V-M4X7.3-T15	
	760L-DECO10			V-M4X5.6-T15	
	760-Z			V-M4X12-T15	

## NÁHRADNÍ DÍLY

	DRŽÁKY	STANDARDNÍ ZPŮSOB UPÍNÁNÍ (A)		ZPŮSOB UPÍNÁNÍ (B)	
					
<b>770</b>	770 / -JET 770R	V-M4X9-T15 V-M4X7.3-T15	C-T15	-	-
<b>780</b>	780 / -JET	V-M4X9-T15	C-T15	-	-
<b>7050</b>	7050	V-M4X9-T15	C-T15	-	-
<b>7060</b>	7060	V-M4X9-T15	C-T15	-	-
<b>W</b>	W750 / W760 / -JET	V-M4X11.5-T15	C-T15	-	-
<b>C3</b>	C3-740 C3-760	V-M3X7-T8 V-M4X9-T15	C-T8 C-T15	-	-
<b>C4</b>	C4-750 C4-760	V-M4X9-T15	C-T15	-	-
<b>HSK</b>	HSK-T40-740 HSK-T40-760	V-M3X7-T8 V-M4X9-T15	C-T8 C-T15	-	-
<b>MultiSwiss</b>	730R-MULTISWISS 750R-MULTISWISS	V-M3X5.5-T8 V-M4X7.3-T15	C-T8 C-T15	-	-
<b>Schütte</b>	DT20-760-JET DT30-760-JET	V-M4X9-T15	C-T15	-	-

# SYSTEM ZNAČENÍ DESTIČEK TOP-Line série 700

7 6 4 X - 2.0 - R20 - HTA

Velikost

Rádus

Sorta

Řezná geometrie / Utvařec třísek / Speciální vlastnosti

## Typ obrábění

1

UPICHOVÁNÍ

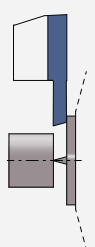

2

STRANOVÉ SOUSTRUŽENÍ

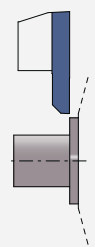

3

ZPĚTNÉ SOUSTRUŽENÍ

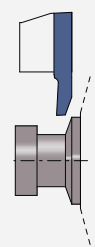

4

ZAPICHOVÁNÍ + SOUSTRUŽENÍ

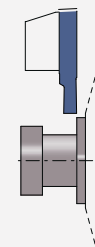

5

ZAPICHOVÁNÍ

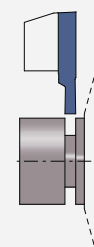

6

SOUSTRUŽENÍ ZÁVITŮ

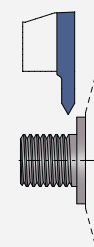

7

RÁDIUSOVÉ DESTIČKY

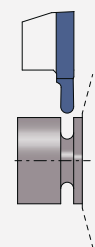

## Produktové série

system pro snazší rozpoznání kompatibility destiček a držáku

L = 3, 5 (LICHÁ ČÍSLA)

R = 4, 6 (SUDÁ ČÍSLA)

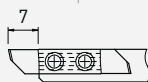
L  
730R  
740

MALÝ TYP

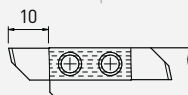
L  
750R  
760

VELKÝ TYP

APPLITEC série 700

Upínací systém s posunutými zuby a dvěma šroubky



# 100% tuhost!

Upínací systém Applitec s posunutými zuby

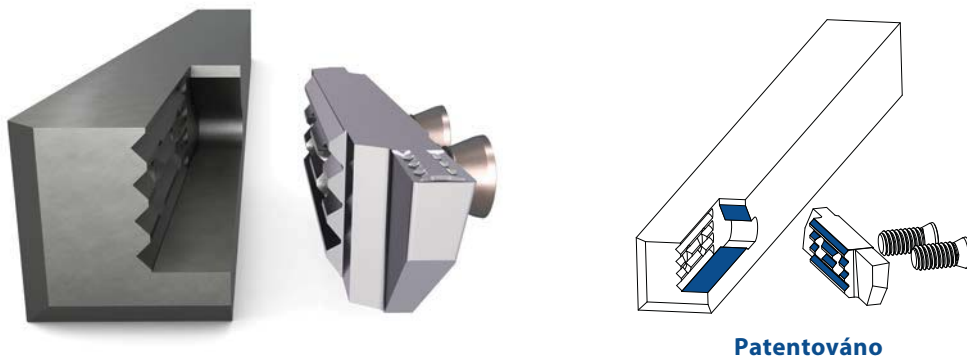

**Patentováno**

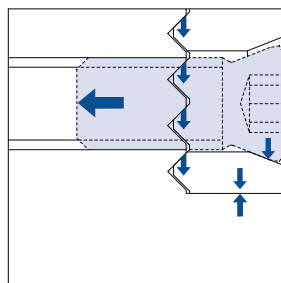

**Standardní způsob upínání - A**

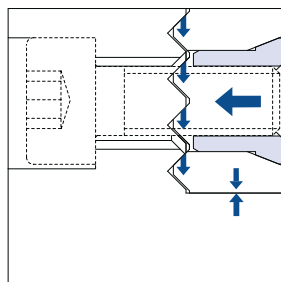
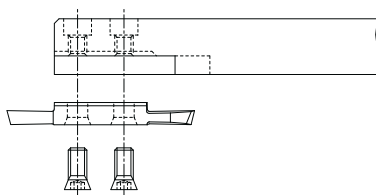

**Způsob upínání - B\***

**z opačné strany držáku, je možno pohodlně měnit  
destičku bez vyndání držáku ze stroje**

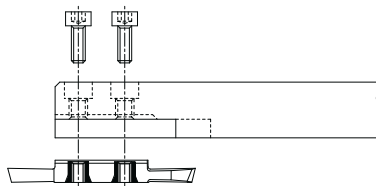

pro objednání destiček s upínáním typu B  
prosím uveďte **za objednacím číslem  
destičky - B**

\* = na vyžádání

## Geometrie 700-ZX

Výborné utváření třísek při obrábění  
obtížných materiálů



K výběru je mnoho různých geometrií



## 700 - honováno



Pozitivní geometrie 5° se zesílenou řeznou hranou (honováno)  
Vyšší životnost nástroje v abrazivních materiálech (uhlíkové oceli a legované oceli)

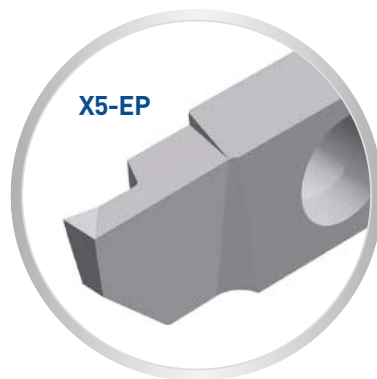

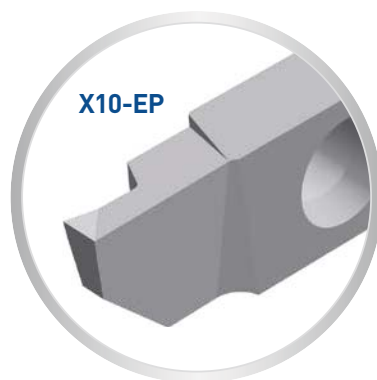

Pozitivní geometrie 10° se zesílenou řeznou hranou (honováno)  
Vyšší životnost nástroje v houževnatých materiálech (nerezové oceli)















## DOPORUČENÉ POUŽITÍ PRO UPICHOVÁNÍ

700 série

ŘEZNÁ GEOMETRIE	AUTOMATOVÉ OCELI	OCELI	NEREZOVÉ OCELI	HLINÍK	TITAN	MOSAZ, BRONZ	MĚĎ	★	PRVNÍ VOLBA
								☆	DOPORUČENO
								☑	PRO KŘEHKÉ A VELMI MALÉ OBROBKY
 0°	★	☑	☑	☑	☑	★	☑	Velmi snadné přebušování	
 X4°	★	★	★	☑	☑		☑	Snížení řezné síly, přebušování možné	
 XF	☆	★	★				☆	Pro obtížné materiály (zesílená špička)	
 X12°			☆	★	★		★	Velmi dobré utváření třísky	
 X25°			☆	★	☆		☆	Pro lepkavé materiály s dlouhou třískou	
 U	☆	☆	☆					Pro zúžení třísky, snadné přebušování	
 ZU8	★	★	★	☆ <5% Si	☆	☆		Velmi dobré utváření třísky (honované ostří) f: min 0,02 mm/ot.	

## DOPORUČENÉ POUŽITÍ PRO SOUSTRUŽENÍ

## 700 série

ŘEZNÁ GEOMETRIE	AUTOMATOVÉ OCELI	OCELI	NEREZOVÉ OCELI	HLINÍK	TITAN	MOSAZ, BRONZ	MĚĎ	★	PRVNÍ VOLBA
								☆	DOPORUČENO
								⊗	PRO KŘEHKÉ A VELMI MALÉ OBROBKY
 0°	★	⊗	⊗	⊗	⊗	★	⊗	Umožňuje snadné přebroušování	
 X	★	★	★	★	★		★	Velmi dobré utváření tříšek	
 X5-EP	★	★	☆					Velmi dobré utváření třísky (honované ostří) f: min 0,02 mm/ot.	
 X10-EP	☆	☆	★	☆	☆			Velmi dobré utváření třísky (honované ostří) f: min 0,02 mm/ot.	
 VX800	★	★	☆	☆	☆		☆	Velmi dobré utváření tříšek	
 VX8°	★	★	☆	☆	☆		☆	Velmi dobré utváření tříšek	
 VUX	☆	☆	★	☆	★		☆	Obrábění v obou směrech	
 VX15°	☆		☆	★	★		★	Velmi dobré utváření tříšek	
 VS	☆		☆	⊗	⊗		⊗	Lehké dokončovací obrábění	
 ZX10	★	★	★	☆ <5% Si	☆	☆		Velmi dobré utváření třísky f: min 0,02 mm/ot.	
 ZX17			☆	★ <5% Si	★		★	Velmi dobré utváření třísky f: min 0,02 mm/ot.	
 ZX25			☆	★ <5% Si	★		★	Velmi dobré utváření třísky f: min 0,02 mm/ot.	
 ZXT	★	★	★	☆ <5% Si	☆	☆		Velmi dobré utváření třísky f: min 0,02 mm/ot.	

**MIKROZRNNÉ SORTY TVRDOKOVU  
SE ZVÝŠENOU HOUŽEVNATOSTÍ**
**μK 20**

<b>TiAlN</b> μK20 + PVD povlak	<b>TiAlX</b> μK20 + PVD povlak	<b>TiN</b> μK20 + PVD povlak
<ul style="list-style-type: none"> <li>• nejlepší univerzální sorta</li> <li>• první volba pro obrábění ocelí, nerezových ocelí a slitin titanu</li> <li>• velmi dobrá tepelná odolnost</li> </ul>	<ul style="list-style-type: none"> <li>• sorta s vysokou odolností proti opotřebení a tepelnou odolností. Vhodné pro následující materiály: 304, 316L, 317L, 904, Phynox</li> <li>• vhodné pro oceli s vyšším obsahem chromu, niklu, vanadu a molybdenu</li> </ul>	<ul style="list-style-type: none"> <li>• sorta pro lehké obrábění materiálů, které mají tendenci k tvorbě nárůstku</li> <li>• velmi nízký koeficient tření</li> <li>• není vhodné pro obrábění titanu</li> </ul>

<b>LOX</b> μK20 + PVD povlak	<b>N (μK20)</b> nepovlakovaný
<ul style="list-style-type: none"> <li>• sorta s vysokou odolností proti opotřebení a tepelnou odolností. Doporučeno pro následující materiály: nerezové oceli, titan, slitiny niklu, oceli &gt; 50 HRC</li> <li>• vhodné i pro následující oceli: ETG88, ETG100, 36SMnPb14</li> </ul>	<ul style="list-style-type: none"> <li>• vhodné pro přerušovaný řez a nestabilní podmínky</li> </ul>

**MIKROZRNNÉ SORTY TVRDOKOVU  
SE ZVÝŠENOU ODOLNOSTÍ PROTI OPOTŘEBENÍ**

**μK 10**

<p><b>HTA</b> μK10 + PVD povlak</p>	<p><b>HTAX</b> μK10 + PVD povlak</p>	<p><b>HTiN</b> μK10 + PVD povlak</p>
<ul style="list-style-type: none"> <li>• sorta velmi odolná proti opotřebení</li> <li>• pro lehké obrábění ocelí, nerezových ocelí a titanu za stabilních podmínek</li> </ul>	<ul style="list-style-type: none"> <li>• sorta s vysokou odolností proti opotřebení a tepelnou odolností. Pro lehké obrábění malých součástek nízkou řeznou rychlostí. Vhodné pro následující materiály: 304, 316L, 317L, 904, Phynox</li> <li>• vhodné pro oceli s vyšším obsahem chromu, niklu, vanadu a molybdenu</li> </ul>	<ul style="list-style-type: none"> <li>• sorta pro lehké obrábění materiálů, které mají tendenci k tvorbě nárůstků</li> <li>• velmi nízký koeficient tření</li> <li>• není vhodné pro obrábění titanu</li> </ul>

<p><b>HAS</b> μK10 + PVD povlak</p>	<p><b>HN (μK10)</b> nepovlakovaný</p>
<ul style="list-style-type: none"> <li>• sorta pro neželezné kovy</li> <li>• velmi nízký koeficient tření</li> <li>• první volba pro hliník do 5% Si, měď a nízko legovaný titan</li> </ul>	<ul style="list-style-type: none"> <li>• mikrozmrný tvrdokov odolný proti opotřebení</li> <li>• vhodný pro obrábění nízkolegovaného titanu</li> <li>• není vhodné pro přerušovaný řez a nestabilní podmínky obrábění</li> </ul>

## STANDARDNÍ ŘEZNÉ PODMÍNKY

MATERIÁL	SOUSTRUŽENÍ			UPICHOVÁNÍ		
	VC	HLOUBKA REZU	POSUV	VC	ŠÍŘKA DESTIČKY	POSUV
	(m/min)	(mm)	(mm/ot.)	(m/min)	(mm)	(mm/ot.)
AUTOMATOVÉ OCELI <b>P</b>	120 - 200	0.05 - 1.0 1.0 - 4.0	0.01 - 0.15 0.05 - 0.25	80 - 150	0.50 - 1.50 1.50 - 3.50	0.01 - 0.08 0.03 - 0.15
OCELI < 600 N/mm <sup>2</sup> <b>P</b>	80 - 160	0.05 - 1.0 1.0 - 4.0	0.01 - 0.15 0.05 - 0.25	70 - 120	0.50 - 1.50 1.50 - 3.50	0.01 - 0.06 0.03 - 0.12
OCELI < 800 N/mm <sup>2</sup> <b>P</b>	60 - 120	0.05 - 1.0 1.0 - 4.0	0.01 - 0.10 0.05 - 0.20	60 - 100	0.50 - 1.50 1.50 - 3.50	0.01 - 0.05 0.03 - 0.10
OCELI > 800 N/mm <sup>2</sup> <b>P</b>	50 - 100	0.05 - 1.0 1.0 - 3.0	0.01 - 0.08 0.05 - 0.15	40 - 80	0.50 - 1.50 1.50 - 3.50	0.01 - 0.04 0.03 - 0.08
NEREZOVÉ OCELI <b>M</b>	60 - 120	0.05 - 1.0 1.0 - 3.0	0.01 - 0.08 0.05 - 0.15	60 - 100	0.50 - 1.50 1.50 - 3.50	0.01 - 0.04 0.03 - 0.08
HLINÍK Si <12% <b>N</b>	200 - 1000	0.05 - 1.0 1.0 - 4.0	0.01 - 0.20 0.05 - 0.40	180 - 400	0.50 - 1.50 1.50 - 3.50	0.01 - 0.10 0.03 - 0.20
HLINÍK Si >12% <b>N</b>	180 - 800	0.05 - 1.0 1.0 - 4.0	0.01 - 0.20 0.05 - 0.40	150 - 300	0.50 - 1.50 1.50 - 3.50	0.01 - 0.10 0.03 - 0.20
MĚĎ, MOSAZ, BRONZ <b>N</b>	100 - 500	0.05 - 1.0 1.0 - 4.0	0.01 - 0.20 0.05 - 0.35	100 - 300	0.50 - 1.50 1.50 - 3.50	0.01 - 0.10 0.03 - 0.20
TITAN <b>S</b>	30 - 70	0.05 - 1.0 1.0 - 4.0	0.01 - 0.08 0.05 - 0.15	30 - 50	0.50 - 1.50 1.50 - 3.50	0.01 - 0.03 0.03 - 0.06



## DOPORUČENÍ PRO PRVNÍ SEŘÍZENÍ

HRUBOVÁNÍ	DOKONČOVÁNÍ
<ul style="list-style-type: none"><li>• STŘEDNÍ ŘEZNÁ RYCHLOST</li><li>• VYSOKÝ POSUV</li></ul>	<ul style="list-style-type: none"><li>• VYSOKÁ ŘEZNÁ RYCHLOST</li><li>• NÍZKÝ POSUV</li></ul>

## DŮLEŽITÉ POZNÁMKY

- v mnoha případech není možné díky limitům stroje dosáhnout doporučené řezné rychlosti
- nástroje Applitec jsou navrženy tak, aby efektivně fungovaly i při nepříznivých řezných podmínkách
- nástroje lze tedy použít i za podmínek které nejsou uvedeny v tabulce na předchozí stránce