

Tvrđokovové frézy S OSAZENOU STOPKOU

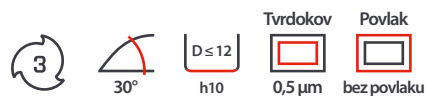

▶ 3383 3-břité OSTRÉ frézy s osazenou stopkou

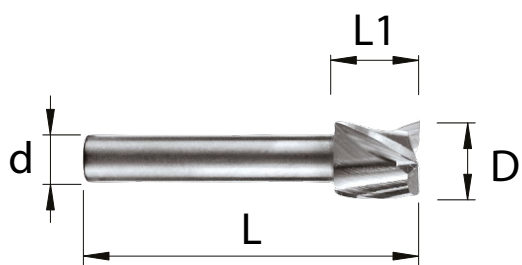

Objednací číslo	D h10 (mm)	L1 (mm)	d h6 (mm)	L (mm)	Standardní položka
3383-8,0	8	8	6	40	<input checked="" type="checkbox"/>
3383-10,0	10	10	6	40	<input checked="" type="checkbox"/>
3383-12,0	12	12	6	40	<input checked="" type="checkbox"/>

▶ 3831/3833 10-břité OSTRÉ frézy s osazenou stopkou

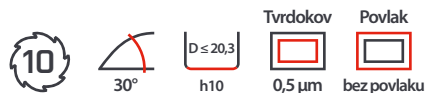
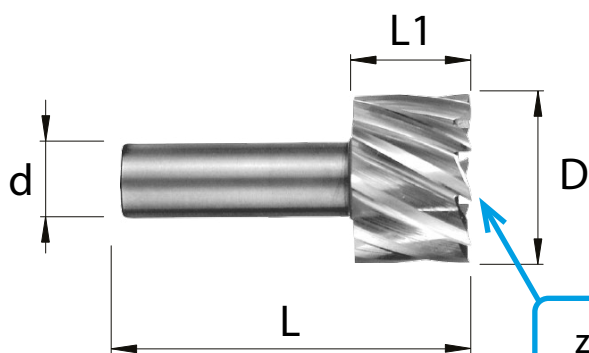

Objednací číslo	D h10 (mm)	L1 (mm)	d h6 (mm)	L (mm)	Standardní položka
3831	16,3	15	10	45	<input checked="" type="checkbox"/>
3833	20,3	15	10	45	<input checked="" type="checkbox"/>