



# INOFlex<sup>®</sup> VD

4-Backen-Handspannfutter ohne Durchgang

4-jaw closed center manual chuck

## ANWENDUNG

- Spannen von runden, quadratischen/rechteckigen und geometrisch unregelmäßigen Bauteilen
- Für verformungsempfindliche Bauteile geeignet
- Innen- und Außenspannung

## TECHNISCHE MERKMALE

- Zentrisches ausgleichendes Spannen
- Spannhubkontrolle

## APPLICATION

- Clamping of round parts
- Clamping of square/rectangular parts
- Clamping of irregular parts
- For deformation sensitive parts
- Internal and external clamping

## TECHNICAL FEATURES

- Compensating concentric clamping
- Clamping stroke control

Technische Daten technical information		VD016	VD021	VD026	VD031	VD040	VD050	VD063	VD080	VD100	VD120
Ident-Nr. / Ident-no.		841016	841021	841026	841031	841040	841050	841063	841080	841100	841120
Durchmesser diameter	mm	165	210	255	315	400	500	630	800	990	1150
Hub pro Backe radial jaw stroke	mm	4,3	5,2	5,2	6,1	6,9	8,7	11,3	11,3	11,3	11,3
Ausgleichshub compensation	mm	2,5	3,5	3,5	4	4,5	6,1	8	8	8	8
max. Anzugsmoment max. torque	Nm	70	110	145	180	245	270	280	280	280	280
max. Spannkraft max. gripping force	kN	70	95	110	135	170	185	200	200	200	200
max. Drehzahl max. speed	1/min r.p.m.	3500	3000	2700	2200	1500	1100	950	800	650	600
Masse (ohne Backen) weight (without top jaws)	kg	12	22	39	75	127	226	340	545	720	1100
Massenträgheitsmoment moment of inertia	kg · m <sup>2</sup>	0,04	0,12	0,32	0,97	2,63	7,39	16,9	24,5	84,5	176,4
Nutenstein standard t-nut	—	GP05	GP07	GP11	GP11	GP13	GP21	GP21	GP21	GP21	GP21
Standard weiche Aufsatzbacke standard soft jaw	—	VS10	VS12	VS16	VS16	VS21	VS25	VS25	VS25	VS25	VS25
Standard harte Aufsatzbacke standard hard jaw	—	VG10	VG12	VG16	VG16	VG21	VG25	VG25	VG25	VG25	VG25

# INOFlex® VD

Spannkraft-/Drehzahl-Diagramm  
Clamping force - speed diagram

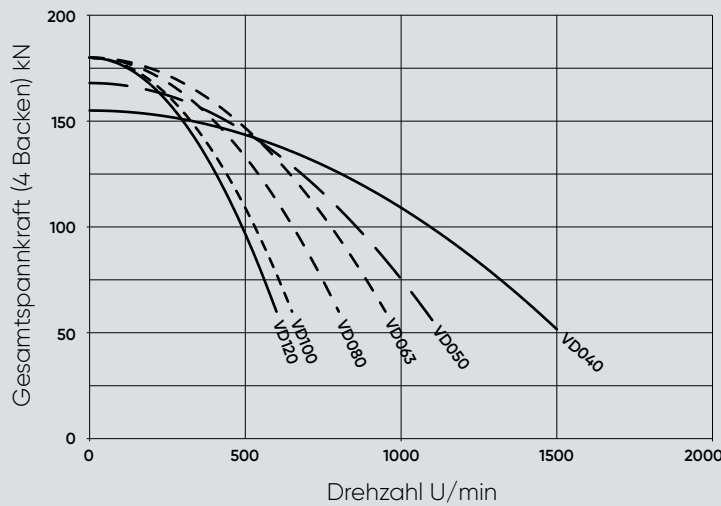
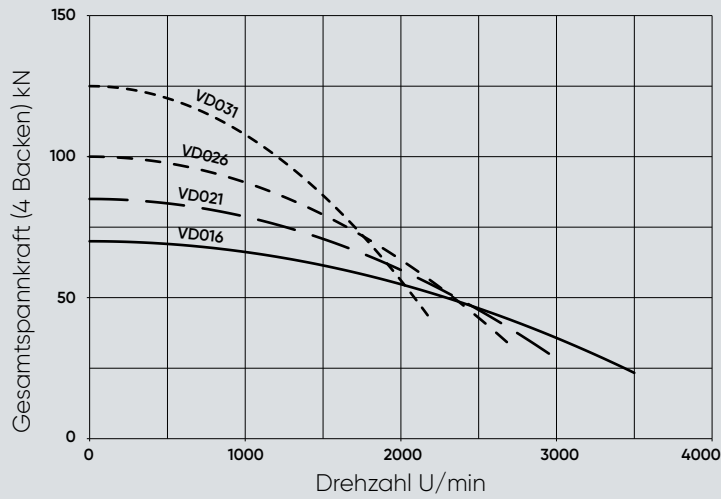

Beim Einsatz der weichen Standardbacke bündig außen aufgebaut.  
When using the soft standard jaw mounted even with the outer diameter of the chuck.

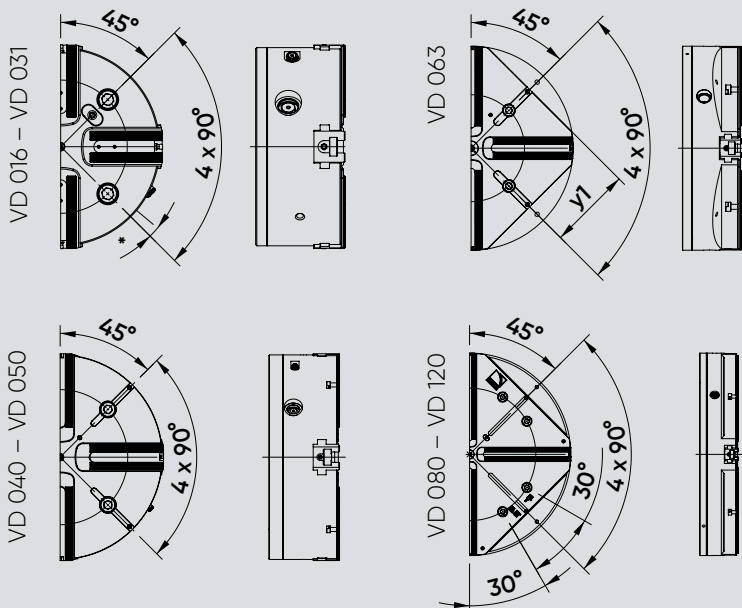

\* Lochkreis bei VD 016 um 5° nach links versetzt  
\* Bolt circle in VD 016 displaced by 5° to the left

Produktausblick  
2022 – Auch als Handspannung mit Durchgang  
Product outlook  
2022 – Also as manual clamping with through hole

	VD050	VD063	VD080	VD100	VD120
100	630	800	990	1150	
180	380	520	720	720	
30,2	330,2	463,6	647,6	647,6	
58,5	163,5	163,5	169,5	169,7	
8	8	8	8	8	
80	246	315	420	498	
10	60	60	60	60	
10,5	10,5	10,5	10,5	10,3	
3,0 x 60°	3,0 x 60°	3,0 x 60°	3,0 x 60°	3,0 x 60°	
6	6	6	6	6	
6,4	16,4	16,4	16,4	17,4	
52,8	314,3	399,3	504,3	574,3	
M24 x 140, 4 x	M24 x 130, 4 x	M24 x 180, 7 x	M30 x 120, 7 x	M30 x 180, 7 x	
16	34,3	41,5	41,5	41,5	
12	59	59	65	65	
11	21	21	21	21	
10	60	60	60	60	
10 / 150	80 / 228	80 / 295	80 / 395	80 / 476	
15	25	25	25	25	
M20 x 55	M20 x 55	M20 x 55	M20 x 55	M20 x 55	
4	22	22	22	22	
13	40	40	40	40	
15	38	38	38	38	
16	16	16	16	16	
33	200	285	245	290	



**IN**

4-E

4-j

## ANWENDUNG

- Spannen von runden, quadratischen/rechteckigen/geometrisch unregelmäßigen Bauteilen
- Für verformungsempfindliche Bauteile geeignet
- Innen- und Außenspannung

## TECHNISCHE MERKMALE

- Zentrisches ausgleichendes Spannen
- Spannhubkontrolle

Technische Daten <i>technical information</i>		VD016
Ident-Nr. / <i>ident-no.</i>		841016
Durchmesser <i>diameter</i>	mm	165
Hub pro Backe <i>radial jaw stroke</i>	mm	4,3
Ausgleichshub <i>compensation</i>	mm	2,5
max. Anzugsmoment <i>max. torque</i>	Nm	70
max. Spannkraft <i>max. gripping force</i>	kN	70
max. Drehzahl <i>max. speed</i>	1/min r.p.m.	3500
Masse (ohne Backen) <i>weight (without top jaws)</i>	kg	12
Massenträgheitsmoment <i>moment of inertia</i>	kg · m <sup>2</sup>	0,04
Nutenstein <i>standard t-nut</i>	—	GP05
Standard weiche Aufsatzbacke <i>standard soft jaw</i>	—	VS10
Standard harte Aufsatzbacke <i>standard hard jaw</i>	—	VG10

# INOFlex® VD

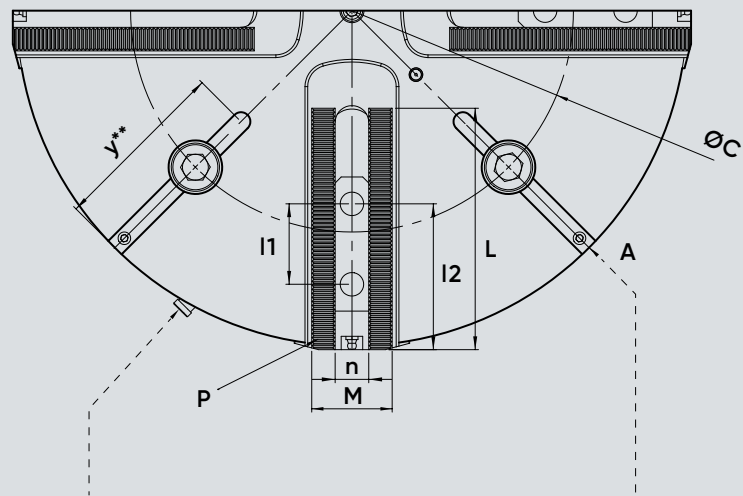

**Hubkontrolle**  
*Stroke control*

**Ansicht A**

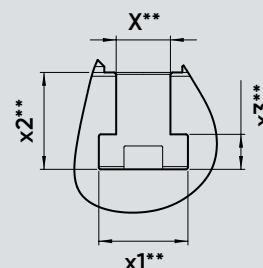

\*\* Ab VD 040

\*\* starting at VD 040

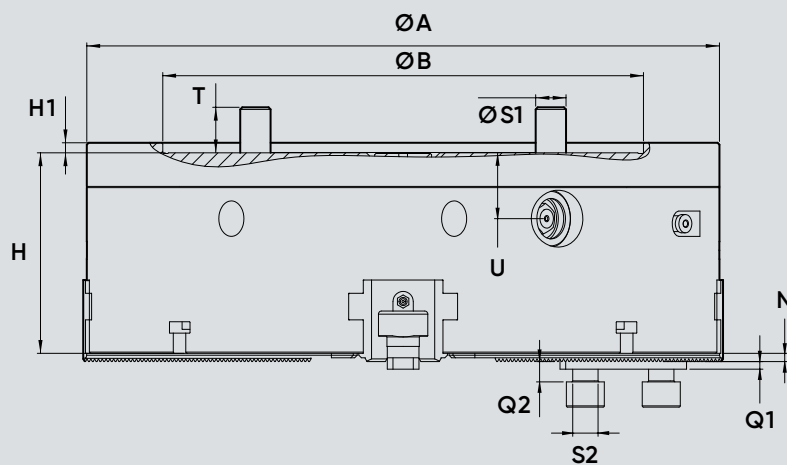



Schau dir das VD-Handpannfutter  
im Detail an!  
Look at the VD-manual chuck in detail!

Produktausblick  
2022 – Auch als Hand-  
spannung mit Durch-  
gang Product outlook  
2022 – Also as manual  
clamping with  
through hole



Abmessungen dimensions	VD016	VD021	VD026	VD031	VD040	VD050	VD063	VD080	VD100	VD120
A mm	165	210	255	315	400	500	630	800	990	1150
B H6 mm	140	170	220	220	300	380	380	520	720	720
C mm	104,8	133,4	171,4	171,4	235	330,2	330,2	463,6	647,6	647,6
H mm	76	85	105	130	136,5	158,5	163,5	163,5	169,5	169,7
H1 mm	5	5	5	5	5	8	8	8	8	8
L mm	60	78	93	111	141	180	246	315	420	498
M mm	31	35,5	40	40	50	60	60	60	60	60
N mm	5	5	5	5	6,5	6,5	10,5	10,5	10,5	10,3
Verzahnung serration	P mm	1,5 x 60°	1,5 x 60°	1,5 x 60°	1,5 x 60°	1,5 x 60°	3,0 x 60°	3,0 x 60°	3,0 x 60°	3,0 x 60°
	Q1 mm	2,5	3	3	3	3,5	6	6	6	6
	Q2 mm	10,5	11,5	11,5	11,5	11,5	16,4	16,4	16,4	17,4
Futter geöffnet chuck open	R mm	84,8	107,9	130,7	161,1	201,9	252,8	314,3	399,3	504,3
	S1 mm	M10 x 80, 4x	M12 x 90, 4x	M16 x 110, 4x	M16 x 130, 4x	M20 x 110, 4x	M24 x 140, 4x	M24 x 130, 4x	M24 x 180, 7x	M30 x 120, 7x
	T mm	16	17,6	21,6	22,6	30	36	34,3	41,5	41,5
	U mm	28	32	37	50	53	52	59	59	65
Schlüsselweite wrench width	W mm	12	12	17	17	21	21	21	21	21
	I1 mm	18	20	30	30	30	60	60	60	60
min./max.	I2 mm	25 / 52	28 / 68	41 / 60	41 / 97	43 / 122	70 / 150	80 / 228	80 / 295	80 / 395
	n H8 mm	10	12	16	16	21	25	25	25	25
	S2 mm	M8 x 25	M10 x 25	M12 x 30	M12 x 30	M16 x 35	M20 x 55	M20 x 55	M20 x 55	M20 x 55
	xH12 mm	—	—	—	—	14	14	22	22	22
	x1 mm	—	—	—	—	23	23	40	40	40
	x2 mm	—	—	—	—	25	25	38	38	38
	x3 mm	—	—	—	—	9	9	16	16	16
	y mm	—	—	—	—	118	133	200	285	245